

OPTIMUM[®]

MASCHINEN - GERMANY

METAL WORKING MACHINERY

THE OPTIMUM IN TERMS OF QUALITY, PRICE-PERFORMANCE AND SERVICE



MAIN CATALOGUE 2019

The OPTIMUM in terms of quality, price-performance and service



Sales and service Germany in Hallstadt/Bamberg

Dear Customer,

To support any conceivable metalworking application, we have composed an assortment in our OPTIMUM domain catalogue that covers many areas with suitable machines. Each of our products impresses with its quality, precision, long service life and value stability. OPTIMUM offers the right machine for most tasks - from bench-top drills to CNC lathes.

Your requirements are our target

For more than 25 years, we have focused on the design, development and production of OPTIMUM machines, and for more than 10 years on CNC machines. We work unceasingly on continually optimising our machines. One important point here is also production, which is of great importance to us. This is why we made a careful choice of manufacturers to supplement our own production facilities. We set great store by the fact that these manufacturers meet our internal quality requirements. Besides our own manufacturing operations, OPTIMUM exclusively relies on manufacturers who meet our requirements. This means that we can offer you metalworking machines that impress on many scores.

OPTIMUM has built up a good reputation in the course of the years on what is a continually changing and developing tool and machine market. We are proud to say that we combine expertise, experience and a balanced price-performance ratio. Our utmost priority is you as a satisfied customer. With our motivated and expert personnel we strive to complete OPTIMUM's know-how and propagate it to you our customers.



Kilian Stürmer
Managing Directors



DISCOVER OUR PRODUCT VIDEOS NOW!

All of our product videos are available for you to watch on our YouTube channel **OPTIMUM Maschinen Germany GmbH**.
Subscribe to our YouTube channel, to avoid missing any of the new videos.





Dealers and service

Thanks to our comprehensive network of specialist dealers, you always have a local partner with OPTIMUM who guarantees the best possible advice, intensive support, and trouble-free after-

sales service. And, of course, our expert staff is there to help you at any time. Please don't hesitate to contact our qualified team if you have any questions. We are happy to help.

Our products

Are you looking for a functional machine that offers a comprehensive feature set at an attractive price? Then you are making the right decision in purchasing an OPTIMUM metalworking machine. Our machines impress with excellent quality, precise manufacturing, and they offer an "OPTIMUM" price-performance ratio. We cater to a comprehensive tool

machine and sheet metal working programme and are guaranteed to have the right machine variant for your needs in our assortment. You can rely on OPTIMUM, because we can realise every single one of your requirements in the metalworking environment. This main catalogue will give you an impression of our capabilities and our wide product portfolio.

On-site for you: in Europe and worldwide

For many years, OPTIMUM Maschinen Germany has been synonymous with the development, design and production of metalworking machines and CNC machines characterised by high quality standards. In the course of the years, we have continually expanded our sales and service network.

Today, OPTIMUM Maschinen Germany GmbH, German company, collaborates globally with professional partners from its headquarters in Hallstadt near Bamberg.

You will find OPTIMUM subsidiaries with strong dealers. Our international sales network extends well beyond Germany's borders to many countries all over the world. This helps us to ensure that our customers can rely on the fast, uncomplicated and service-oriented expertise and quality standards of OPTIMUM thanks to our extensive sales organisation. We have established a responsible market position that you can trust in the course of the years!



All OPTIMUM products are produced under high quality requirements.



OPTIMUM plant in Yangzhou, China

Production

Since 2003, OPTIMUM Maschinen Germany GmbH has produced a large share of its metalworking machines in its own factory in Yangzhou China. The quality here is monitored by German quality management officers and production supervisors. A further major part of our OPTIMUM metalworking machines is exclusively produced for OPTIMUM in line with special requirements within the company group.



Production on our own CNC machines



Drilling machine assembly



Quality

OPTIMUM products are produced under high quality requirements. A price comparison with equivalent and comparable products will give you the assurance that our OPTIMUM machines are always products that stand up to any comparison in terms of operating convenience, equipment level, quality, technology and value for money and are thus always a good buy. Check out the robust design and durability for yourself; this is what our machines stand for in a metalworking world.

You can purchase the OPTIMUM brand with confidence, and assure the best possible quality for your operations. There are many products that look identical, or similar, on the market, but which by no means achieve our OPTIMUM quality standards.



Lathe production

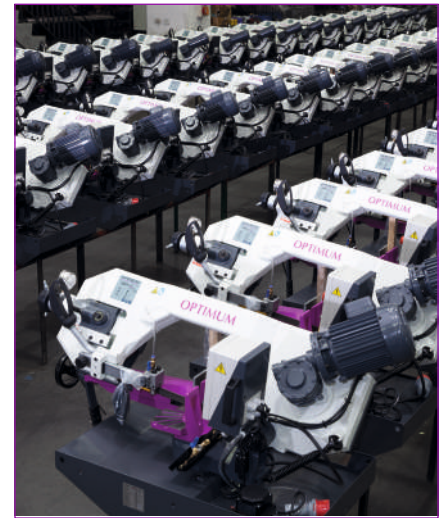

Metal-cutting band saw production



German Quality – made in China



Our production facilities

Optimum Maschinen Germany GmbH has commenced production in 2006 in Touqiao Town near Yangzhou in Jiangsu Province, only about three hours by car from Shanghai, on a total area of 20 000 square meters - a building floor space of 9 000 square meters with 180 employees, including 40 technicians.

Today, we produce our Optimum machine program in three production plants with a total area of 74 000 square meters and a building floor space of 30 000 m² with about 230 employees in production.

We permanently meet requirements for precision machining and economic efficiency.

We develop and configure the best solutions for our customers and take responsibility for them.

Our factories carry out strict technical process and quality controls Based on ISO 9001.

With a team of experienced experts and technicians and advanced production facilities, we produce quality products such as small and medium CNC machining centres, CNC lathes, CNC milling machines, milling and drilling machines and lathes for industrial and home use.



DIN EN ISO 9001 Excellent quality

Our factory is DIN EN ISO 9001 certified. This means that all company departments and services are subject to strict quality requirements. And this means consistently high quality for you. The objective of high quality is thrilled customers. And it is this attitude that finally helps to achieve this

demanding certification. The key to the long-term success of our enterprise is also a relationship of trust with customers and suppliers. This explains why it is just as important to us as the sustainable quality of our products.





Our standards are high. And we strictly adhere to them

Certified quality in our production facilities

The excellence and safety of our products are assured by a system of internal processes, based on regular and frequent inspections in our factories and along the logistics chain. In order to ensure compliance with the strict requirements, each production site is regularly inspected.

Achieving our quality goals is an important management task



At Optimum, development and production are in the same hands, and the company sets high standards in all areas.

This is why our customers get what they expect from Optimum: innovative, well thought-out products with high practical suitability and an exceptionally long service life.



Quality control



Our company has developed a carefully planned quality management system and is certified according to ISO 9001:2008.

This system is an integral part of our operations and no exceptions or compromises are made or entered into with regard to the quality level of the products from production. Our Quality Assurance department is staffed by skilled employees who ensure that only products of impeccable quality are sold

Quality Assurance department

The Quality Assurance department consists of experienced technicians who are supervised by our German technicians, and attach great importance to high quality and impeccable product quality.

Each production step is checked and compared at all times with the available specifications



We want satisfied customers



This explains why our products' compliance with the customer quality requirements described earlier on is our company's top priority.



Production support

Our Engineering department has a well-coordinated team of specialists with excellent engineering qualifications. Their established expertise allows flexible and creative implementation of all requirements posed for our products and services.

A team of employees directly influences the production process on site through regular training and checks. It is only through this intensive support at the production site that we are in a position to achieve the proverbial OPTIMUM.

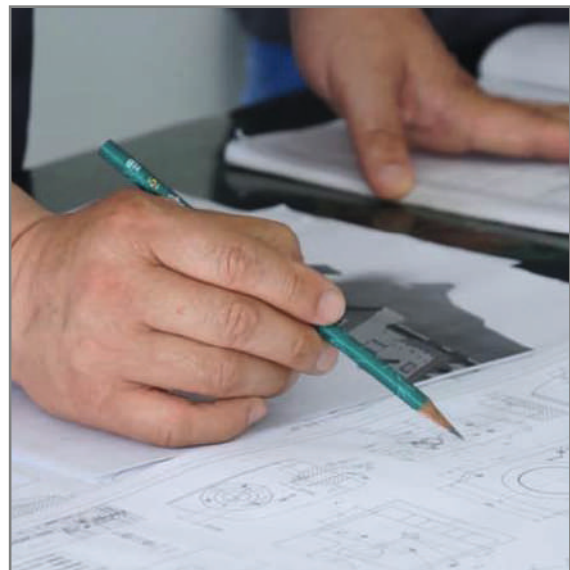



Quality management Production Outbound goods inspection

In addition to adherence to delivery deadlines and service, the quality of our products is extremely important to us. Continuous on-site checks by our quality manager ensure our quality. Our comprehensive incoming goods inspection is performed in line with generally accepted technical guidelines.



Quality management Incoming goods inspection

Our quality managers from Germany are our first contacts for quality compliance on site. They are responsible for the dimensional accuracy of the components, for monitoring and quality assurance of the manufacturing process; they collaborate closely with our Engineering department at head office in Germany, thus ensuring an optimal symbiosis.



Planning

As early as the planning phase our engineering department manages the development of new products, which are manufactured both our facility and facilities operated by our partners. Major benefits: this ensures that market factors and customer requirements are immediately adopted into our workflow, setting the stage for a successful product design.



Development

Development relies exclusively on state-of-the-art 3D CAD software, which we use to create a virtual model of the machine. Besides ensuring optimum functionality of the machines, our development process also targets re-usability of the data generated during the development phase. These data are not only used for devising production documents and manuals, but are also used for computations, for computer-aided manufacturing, and for visualisation and animations.



Practical testing

Our engineers combine theory and practice. To avoid leaving anything to chance in terms of product satisfaction, all of our machines and tools go through application engineering tests, and we also consistently involve selected customers in this process. This means that each new product is expected to prove itself in the daily grind before it comes a fixed part of our product range. Engineering analysis helps us to discover and eliminate any remaining weak points.



The clearly engineering oriented approach of our staff – in addition to the premium quality of our products, and our expert service – contribute towards constantly high levels of customer satisfaction. And our focus on technically affine employees ensures our market success – today and looking forward!



Technical customer support

Our customers rightly expect our specialists to use their knowledge and experience to their utmost satisfaction. Our product consultants support users with technical information. To allow this to happen, our customers can use our free telephone hotline and our info email address to request qualified information and solutions at short notice.



Safeguarding copyrights

To secure the rewards of our technical development work for both ourselves and our customers, patent and utility model protection is essential for our in-house developments. This helps us permanently keep the technical lead that OPTIMUM products have. The entire catalogue is protected by copyright. Additionally, to protect our products, we register our rights to our brands, patents and designs where possible in each individual case. We take strong action against any violation of our intellectual property.



Technical documentation and risk analyses

Our technical authors again achieve a high standardised level that meets or even exceeds all requirements. These huge efforts exclusively serve the purpose of facilitating the process of familiarisation with the machine for our customers, and ensuring permanent and safe operations. Risk mitigation measures are developed to compensate for any safety risks identified in the scope of analysis. Following this, the residual risk is evaluated after implementing the measures.



Supplier management

Regular work meetings between our engineers and suppliers help to transfer our new developments and enhancements into series production at the manufacturing location in a targeted way. This direct support at our production facilities has been indispensable in manufacturing the quality products that our customers have trusted for more than 25 years.



Sales support

The requirements for OPTIMUM machines are equally as diverse as the production requirements of our end customers and the workpieces to be machined. To ensure this, our representatives and retailers have access to the entire application-specific know-how of our engineers in case of queries.

In a qualified and explanatory sales talk, our customers are given the support they need to tune their choice of products to match their needs.



Training

For employees from Engineering, Service and Sales as well as for our customers: Successful use of our products depends and is driven to a decisive extent by the fact that we pass on our technology know-how to our dealers, their sales and service staff and our customers through training sessions. The major benefits: this qualification offers the ability to ensure professionally founded consultancy and problem solving in all dealings with the customer. At our training centre, we offer practically-oriented product training that aim to disseminate professional knowledge in a highly intuitive way.





Supply of spare parts

We know that rapid availability of spare parts is one of the major pre-conditions for a working, customer-oriented service solution. The planning, coordination and provisioning of spare parts is tuned at OPTIMUM Maschinen Germany GmbH so that our customers have the greatest possible benefits in terms of economic efficiency and speed.



Siemens cooperation partner for CNC training

Siemens has for many years been the system supplier of the control and drive technology for CNC-controlled lathes and milling machines by OPTIMUM Maschinen Germany GmbH. Due to our long-standing and successful collaboration, a cooperation partnership for CNC training in Bavaria was agreed in June 2012. Target-group specific courses familiarise the participants of the training program with the various Sinumerik controls.



Service support

...after all, good service is important to us!
In service cases, our OPTIMUM technicians are available at any time with their experience to support your workshop operations and ensure fast and targeted repairs. In close cooperation with the service centre and its internal and external staff, weaknesses are analysed and customer needs registered. These weaknesses and needs are then evaluated from an engineering point of view and set out as tangible requirements or action catalogues.

Table of contents

Drilling machines

DH 55G.....	18
B 50GSM.....	20
DH 45G / DH 45V	22
DH 35G.....	24
B 40GSP / B 40GSM	26
DH 28GSV / DH 32GSV	28
DH 26GT / DH 28GS / DH 32GS	30
DH 40CT	32
DH 40G / DH 40GP	34
DH 24BV / DH 28BV / DH 40BV	36
B 24HV / B 28HV / B 34HV	38
DH 18V.....	40
B 16H / B 24H / B 28H / B 34H	42
DX 17V	44
DX 13V / DX 15V	46
D 17Pro / D 23Pro / D 26Pro / D 33Pro.....	48
RB 6T / RB 8S	50
B 13 / B 14 / B 16 / B 20 / B 25 / B 32	52
RD 4 / RD 5 / RD 6.....	54
RD 3	56

Accessories - Drilling

Compatibility overview accessories.....	58
Accessories - Drilling.....	60
Thermdrill.....	68

Magnetic drilling machines

DM 60V / DM 98V.....	70
DM 50PM	72
DM 36VT.....	73
DM 35 / DM 50 / DM 35PF.....	74
DM 35V / DM 50V.....	76
DM 38VF.....	77

Milling machines

MZ 2 / MZ 4.....	80
MT 8	82
MT 230S.....	84
MT 200.....	86
MT 130S.....	88
MT 100.....	90
MF 2V / MF 4V	92
MF 2-B / MF 4-B.....	94
MT 60.....	96
MT 50.....	98
MT 50E.....	100
MB 4P / MB 4PV	102
MH 50G / MH 50V	104
MH 35G / MH 35V	106
MB 4	108
MH 25V / MH 25SV	110
MH 20V / MH 22V / MH 22VD.....	112
BF 16 Vario.....	114

Accessories - Milling

Compatibility overview vises	116
Accessories - vises	117
Compatibility overview accessories.....	120
Accessories for milling machines	122
Machine bases milling machines	131
Starter set.....	133

Lathes

TH 8020D / TH 8030D	138
TH 6620D / TH 6630D	140
TX 5216 / TX 6222	142
TZ 4 / TZ 4V	144
TH 5620V	146
TH 5615D / TH 5620D / TH 5630D.....	148
TH 4615V	150
TH 4610D / TH 4615D / TH 4620D.....	152

TH 4210V	154
TH 4210 / TH 4210D / TH 4215D.....	156
TH 4010 / TH 4010D / TH 4010V	158
TM 4010 / TM 4010D	160
TH 3610 / TH 3610D.....	162
TH 3309 / TH 3309D / TH 3309V	164
TU 3008 / TU 3008G / TU 3008V	166
TU 2807 / TU 2807V	168
TU 2506 / TU 2506V.....	170
TU 2406 / TU 2406V.....	172
TU 2304 / TU 2304V.....	174
TU 2004V	176
TU 1503V.....	177

Accessories - Turning

Compatibility overview accessories.....	178
Accessories Turning	180

Metal-cutting bandsaws

Metal-cutting circular saws

CS 275 / CS 315.....	196
SD 350AV	198
S 350DG.....	200
S 300DG / S 300DG Vario	202
S 310DG Vario.....	203
SD 280V	204
S 285DG.....	205
S 275N / S 275NV	206
S 210G	207
S 181	208
S 181G	209
S 150G Vario	210
S 131GH.....	211
S 100G	212
SP 11V / SP 13V	213

Sawing - Accessories

Material stand MSR.....	214
Length measuring system LMS.....	215

Grinding/Polishing machines

Drilling/sanding machine GH 20T.....	218
Drill bit grinding machines GH 10T / GH 15T	219
Drilling/sanding machine DG 20.....	220
Drilling/sanding machine GQ-D13	221
Bench grinders GZ 20D - GZ 30DD	222
Bench grinders GU 15 - GU 25, SM 300	223
Vario drive for grinders	224
Combined grinding machines GZ 20C - GZ 25CD	226
Polishing machines GU 20P / GU 25P.....	227
Combined grinding machines GU 15B - GU 25B.....	228
Universal grinding machines GU 20S / GU 25S.....	229
Machine bases grinding machines	230
Belt sanders BSM 75 / BSM 150	232
Belt and disc sander DBS 75	233
Disk grinder TS 305	234

Plate rolling, folding, pressing

Folding machine FP 3	236
Three-roll bending machine BM 3	236
Metal processing SAR 1000.....	237
Lever tin snips PS 125 - PS 300.....	238
Arbor presses DDP 10 - DDP 50	238

Machine accessories

Machine lamps	240
Coolant accessories	242
Digital position display Newall DP 700	244
Digital position display DPA 21 / DPA 22.....	247
Digital position display DRO 5.....	248
Dial gauges/Gauge stand/Spirit level/Test plate	248

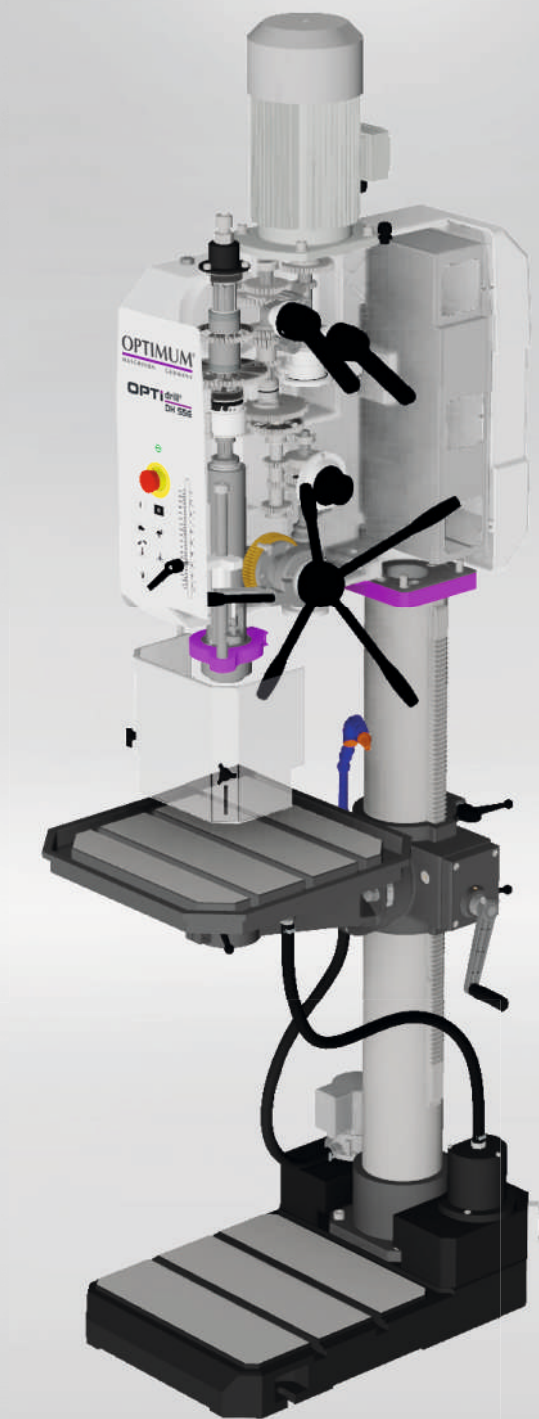

DRILLING MACHINES

GEAR



Drills with gear units
Page 18 - Page 35

BELT-DRIVEN



Belt-driven drills
Page 36 - Page 53

RADIAL



Radial drills
Page 50 - 51 and Page 54 - 57

Heavy duty gearbox drill for industrial use.

With coolant and thread tapping unit, and automatic spindle sleeve feed

Facts that impress in terms of quality, performance and price

- ▶ Heavy, solid cast design
- ▶ Dirt/water-resistant, easy-to-clean membrane keyboard
- ▶ 24 V DC electronics
- ▶ Electrical spindle sleeve feed
- ▶ Drilling depth stop
- ▶ Automatic gearwheel lubrication via oil pump
- ▶ Thread tapping device.
- ▶ Machine lamp integrated in drilling head
- ▶ Generously dimensioned, height adjustable protective screen with safety switch for greatest possible user protection
- ▶ Generously dimensioned drilling table, solid, precision workmanship, with parallel T-slots and recirculating coolant duct, reinforcing ribs on rear, rotates through $\pm 90^\circ$ about the column, laterally tilting
- ▶ Motorised drilling table height adjustment
- ▶ Cooling unit and external coolant tank, can be removed for easier and complete emptying
- ▶ Chip filter in line with Machinery Directive
- ▶ Extremely stable, thick-walled cast-iron column for excellent force absorption
- ▶ Solid base plate with parallel T-slots, precision surface finish
- ▶ Optional footswitch available for toggling between clockwise and anticlockwise run and for thread tapping

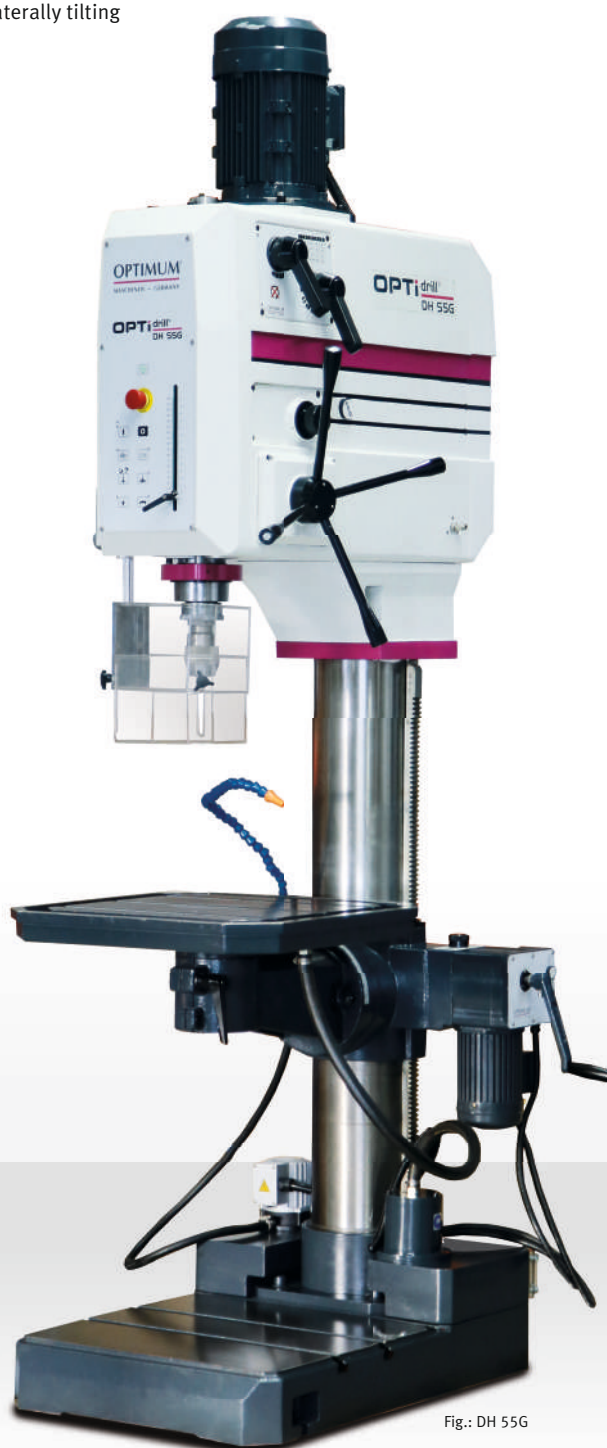

Fig.: DH 55G



Technical specifications, accessories and dimensions

Model	DH 55G
Article no.	3034265
Technical specifications	
Electrical connection	400 V / 3 Ph ~50 Hz
Motor output	2.2 / 2.8 kW
Coolant pump motor	100 W
Drilling performance	
Drilling performance in steel (S235JR)	Ø 55 mm
Continuous drilling performance in steel (S235JR)	Ø 50 mm
Thread tapping steel (S235JR)	M42
Spindle	
Spindle sleeve stroke	200 mm
Spindle seat	MT 4
Throat	400 mm
Automatic spindle sleeve feed	3 speeds: 0.1 / 0.15 / 0.2 mm/rev
Rotational speeds	
Spindle speeds	45 - 2 000 rpm
Number of speeds	16 speeds
Drilling table	
Drilling table workspace L x W	600 x 600 mm
T-slot size / spacing / count	18 mm / 160 mm / 3
Drilling table load bearing capacity	350 kg
Drill table rotation/lateral tilt	360° / ± 90°
Clearance spindle - drilling table	130 - 750 mm
Machine base	
Machine base work area L x W	515 x 570 mm
T-slot size / spacing / count	18 mm / 150 mm / 2
Distance spindle - machine base	max. 1 300 mm
Dimensions	
Column diameter	Ø 200 mm
Length x width x height	850 x 1 050 x 2 500 mm
Weight	850 kg

Accessories	Article no.
Assortment of clamping tools size 16, 58-parts	3352019
Twist drill bits HSS-CO 5%, 25 parts	3201010
NEW Twist drill bits HSS-CO 5%, 51 parts	3201020
NEW Twist drill bits HSS-CO 5%, 41 parts	3201021
Direct quick release chuck 1 - 16 mm	3050574
Reduction sleeve MT 4 - MT 3	3050664
Reduction sleeve MT 4 - MT 2	3050665
Thermdrill MT 2	3060005
Foot switch	3050032

for thread tapping and toggling clockwise/anticlockwise rotation

› More „Accessories for drills“ from page 60



Machine vices	Article no.
BSI 140	3000214
BSI 200	3000220
BSI-Q 140	3000234
BSI-Q 200	3000240

› Information on the vices on page 67

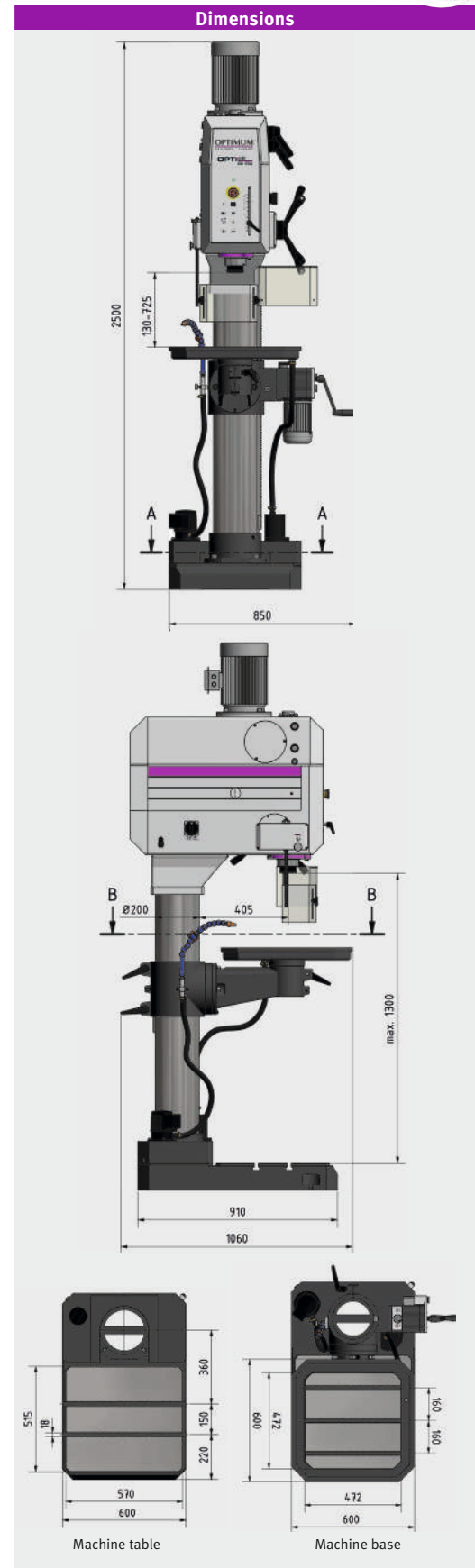

Scope of supply

- › Quick-action drill chuck 1 - 16 mm
- › Morse taper MT 4/B16

Heavy duty gearbox drill for industrial use

With coolant and thread tapping unit, and automatic spindle sleeve feed

Facts that impress in terms of quality, performance and price

- ▶ Heavy, solid cast design
- ▶ Smooth action due to polished gearwheels running in an oil sump
- ▶ Excellent concentricity thanks to tempered and ground main spindle
- ▶ Two-stage drive motor
- ▶ Right-handed/left-handed rotation
- ▶ Automatic gearwheel lubrication via oil pump
- ▶ Thread tapping device.
- ▶ Main switch and motor circuit breaker
- ▶ Motorised table height adjustment
- ▶ Machine lamp integrated into drilling head
- ▶ Generously dimensioned, height adjustable protective screen with safety switch for greatest possible user protection
- ▶ Generously dimensioned drilling table, solid, precision workmanship, with parallel T-slots and recirculating coolant duct, reinforcing ribs on rear, rotates through $\pm 90^\circ$ about the column, laterally tilting
- ▶ Cooling unit and external coolant tank, can be removed for easier and complete emptying
- ▶ Chip filter in line with Machinery Directive
- ▶ Extremely stable, thick-walled cast-iron column – column diameter 200 mm – for excellent force absorption
- ▶ Solid base plate with parallel T-slots, precision surface finish

Heavy, solid
cast design
950 kg
Smooth action, stable

Integrated push-out tool

- › Spindle lock with integrated ejector for easy tool change



Automatic spindle sleeve feed

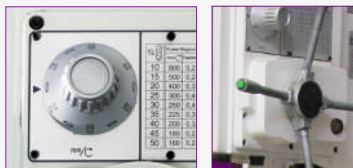

For deep drilling or blind hole drilling, the clutch on the automatic spindle sleeve feed can be released or engaged at any time by pressing the button on the feed handle.

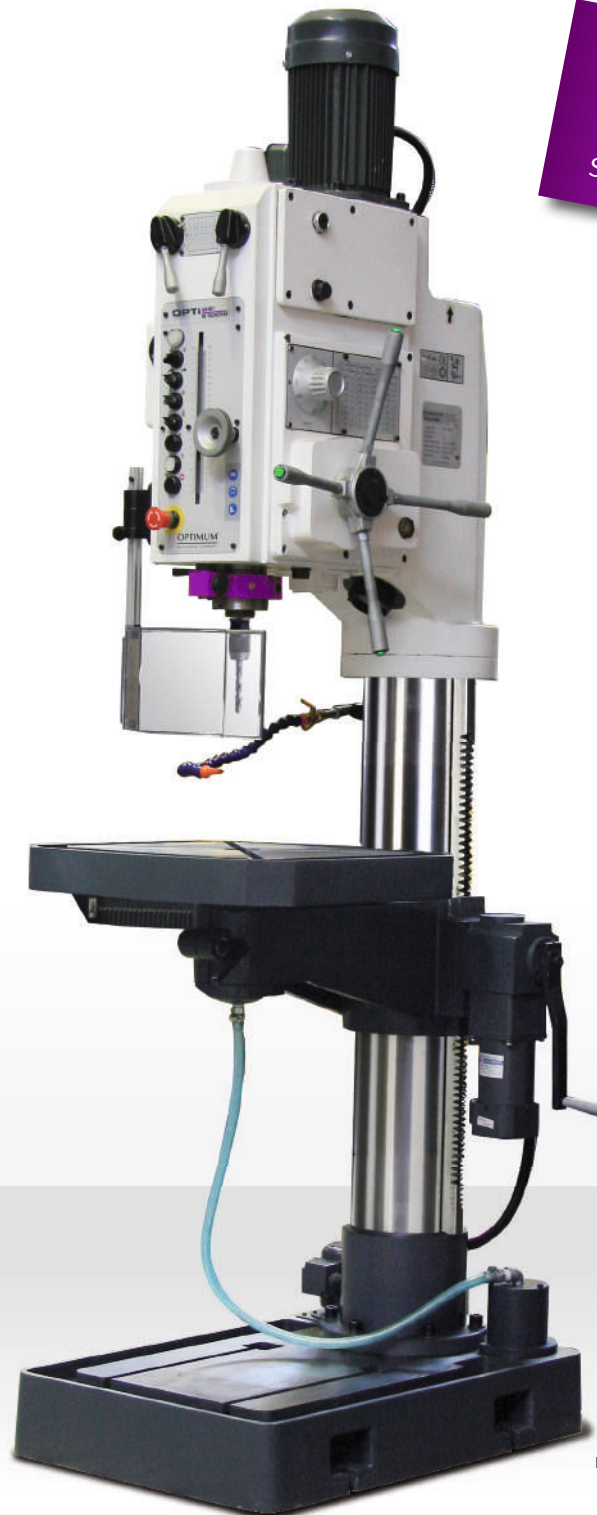

Fig.: B 50GSM



Technical specifications, accessories and dimensions

Model	B 50GSM
Article no.	3034500
Technical specifications	
Electrical connection	400 V / 3 Ph ~50 Hz
Total rated value	2.4/3.0 kW
Coolant pump motor	40 W
Drilling performance	
Drilling performance in steel (S235JR)	Ø 50 mm
Continuous drilling performance in steel (S235JR)	Ø 45 mm
Thread tapping steel (S235JR)	M42
Spindle seat	
Spindle sleeve stroke	230 mm
Spindle seat	MT 4
Throat	375 mm
Autom. spindle sleeve feed	6 speeds: 0.05-0.3 mm/rev
Speeds	
Spindle speeds	54 - 2 090 rpm
Number of speeds	18 speeds
Drilling table	
Workspace drilling table length x width	600 x 600 mm
T-slot size	18 mm, diagonal
Drilling table load bearing capacity	300 kg
Drill table rotation/lateral tilt	360° / ± 90°
Clearance spindle - drilling table	max. 800 mm
Machine base	
Machine base workspace length x width	600 x 520 mm
T-Slot size / no / distance	18 mm / 2 / 280 mm
Distance spindle - machine base	max. 1 300 mm
Dimensions	
Column diameter	Ø 200 mm
Length x width x height	985 x 775 x 2 460 mm
Overall weight	950 kg

Scope of supply

- > Quick-action drill chuck 1 - 16 mm
- > Morse taper MT 4/B16
- > T-slot nuts

Accessories	Article no.
Assortment of clamping tools size 16, 58-parts	3352019
Hold-down device 18 mm/M16	3352032
Twist drill bits HSS-CO 5%, 25 parts	3201010
NEW Twist drill bits HSS-CO 5%, 51 parts	3201020
NEW Twist drill bits HSS-CO 5%, 41 parts	3201021
Direct quick release chuck 1 - 16 mm	3050574
Reduction sleeve MT 4 - MT 3	3050664
Reduction sleeve MT 4 - MT 2	3050665
Thermdrill MT 2	3060005
> More „Accessories for drills“ from page 60	

Machine vices	Article no.
BSI 140	3000214
BSI 200	3000220
BSI-Q 140	3000234
BSI-Q 200	3000240

> Information on the vices on page 67

Dimensions

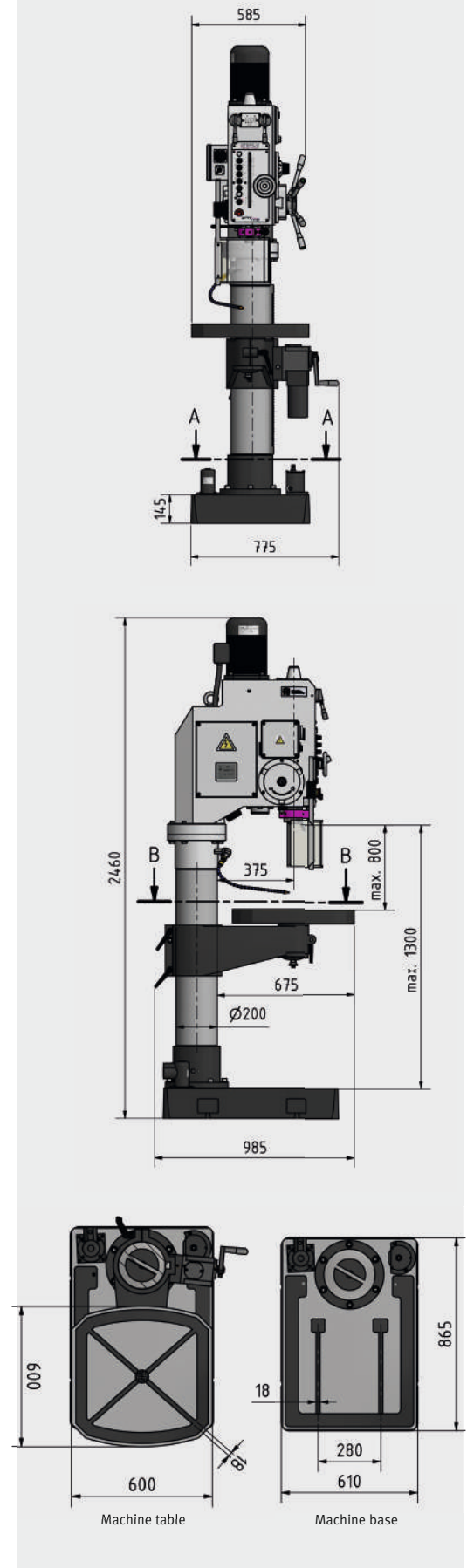

Preface

Drilling

Milling

Turning

Saws

Grinding

Polishing

Lamps

Measuring

Heavy-duty gearbox drilling machine with thread tapping device for industrial applications. DH 45V with continuously adjustable speed control

Facts that impress in terms of quality, performance and price

- ▶ Heavy, solid cast design
- ▶ Dirt- and water-resistant, easy-to-clean membrane keyboard
- ▶ 24 V DC electronics
- ▶ Drilling depth stop
- ▶ Automatic gearwheel lubrication via oil pump
- ▶ Thread tapping device.
- ▶ Machine lamp integrated in drilling head
- ▶ Main switch
- ▶ Generously dimensioned, height adjustable protective screen with safety switch for greatest possible user protection
- ▶ Generously dimensioned drilling table, solid, precision workmanship, with parallel T-slots and recirculating coolant duct, reinforcing ribs on rear, rotates through $\pm 90^\circ$ about the column, laterally tilting

- ▶ Cooling unit and external coolant tank, can be removed for easier and complete emptying
- ▶ Extremely stable, thick-walled cast-iron column for excellent force absorption
- ▶ Solid base plate with parallel T-slots, precision surface finish
- ▶ Optional footswitch available for toggling between clockwise/ anticlockwise run and for thread tapping (Article no. 3050032)

OPTIdrill DH 45V

- ▶ Electrical spindle sleeve feed

OPTIdrill DH 45G

- ▶ Mechanical spindle sleeve feed



Fig.: DH 45G

Figure: DH 45V

DH 45V

Siemens inverter SINAMICS G110M

- › Especially EMC compatible due to compact design
- › Internal safety function



Made in EU

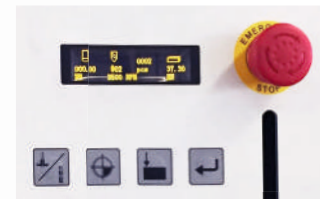

State-of-the-art control solution

- › Easily readable digital display for speed, drilling depth | tapping depth and piece counter
- › Feed deactivation via depth adjustment

WITH AND WITHOUT VARIO



Technical specifications, accessories and dimensions

Model	DH 45G	DH 45V
Article no.	3034255	3034262
Technical specifications		
Electrical connection	400 V / 3 Ph ~50 Hz	
Motor output	2.2 kW	
Coolant pump motor	40 W	
Drilling performance		
Drilling performance in steel (S235JR)	Ø 40 mm	
Continuous drilling performance in steel (S235JR)	Ø 35 mm	
Thread tapping steel (S235JR)	M35	
Spindle		
Spindle sleeve stroke	180 mm	
Spindle seat	MT 4	
Throat	350 mm	
Automatic spindle sleeve feed	3 speeds: 0.1 / 0.15 / 0.2 mm/rev	
Speeds		
Spindle speeds	90 - 1 520 rpm	30 - 2 430 rpm
Number of speeds	8 speeds	4 speeds, electronically controlled
Drilling table		
Drilling table workspace L x W	530 x 530 mm	
T-slot size / spacing / count	16 mm / 3 / 125 mm	
Drilling table load bearing capacity	250 kg	
Drill table rotation/lateral tilt	360° / ± 90°	
Clearance spindle - drilling table	130 - 725 mm	
Machine base		
Machine base work area L x W	435 x 445 mm	
T-slot size / spacing / count	18 mm / 150 mm / 2	
Distance spindle - machine base	max. 1 210 mm	
Dimensions		
Column diameter	Ø 150 mm	
Length x width x height	880 x 595 x 2 445 mm	
Weight	515 kg	

Accessories	Article no.
Assortment of clamping tools size 16, 58-parts	3352019
Assortment of clamping tools size 14, 58-parts	3352018
Twist drill bits HSS-CO 5%, 25 parts	3201010
NEW Twist drill bits HSS-CO 5%, 51 parts	3201020
NEW Twist drill bits HSS-CO 5%, 41 parts	3201021
Direct quick release chuck 1 - 16 mm	3050574
Reduction sleeve MT 4 - MT 3	3050664
Reduction sleeve MT 4 - MT 2	3050665
Thermdrill MT 2	3060005
Foot switch	3050032

for thread tapping and toggling clockwise/anticlockwise rotation

> More „Accessories for drills“ from page 60



Machine vices	Article no.
BSI 140	3000214
BSI 200	3000220
BSI-Q 140	3000234
BSI-Q 200	3000240

* Important information on transport surcharges and „Operation of machines with frequency converters“ on page 249

**The drill (frequency converter) complies with the DIN EN 55011 standard: class C2

Dimensions

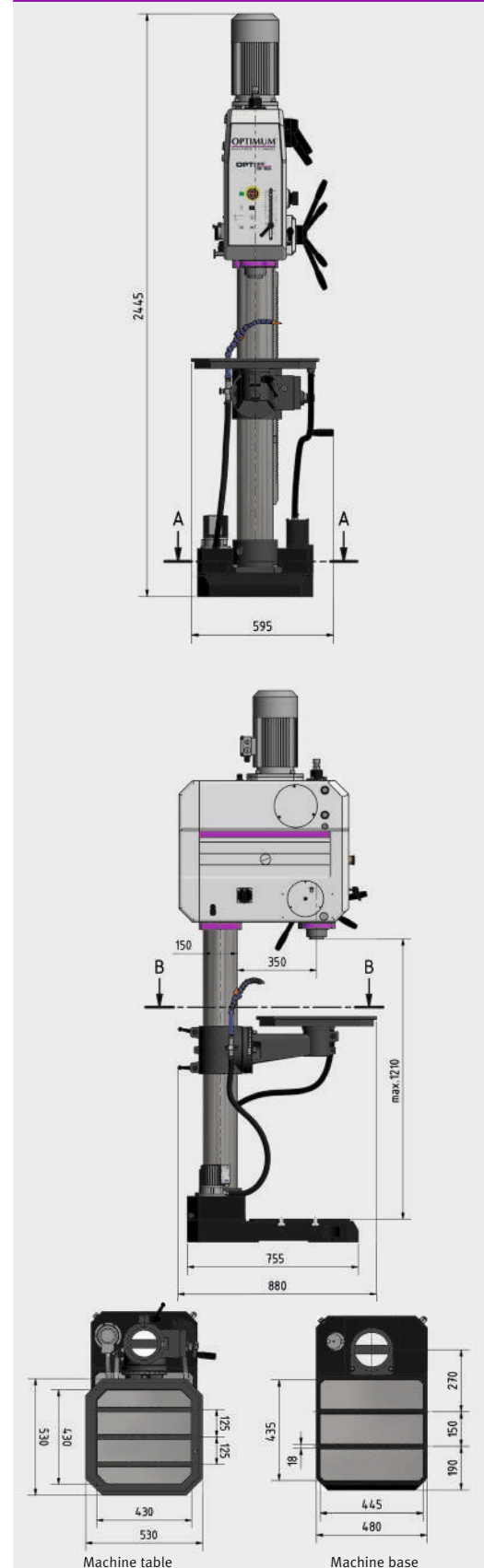

Scope of supply

- > Quick-action drill chuck 1 - 16 mm
- > Morse taper MT 4/B16

Preface

Drilling

Milling

Turning

Saws

Grinding

Polishing

Lamps

Measuring

Gear drilling machine with thread tapping unit. DH 35V with continuously adjustable speed control.

Facts that impress in terms of quality, performance and price

- ▶ Dirt/water-resistant, easy-to-clean membrane keyboard
- ▶ 24 V DC electronics
- ▶ Drilling depth stop
- ▶ Electrical spindle sleeve feed
- ▶ Low-maintenance gear unit running in a closed oil sump
- ▶ Thread tapping device.
- ▶ Machine lamp integrated in drilling head
- ▶ Main switch
- ▶ Generously dimensioned, height adjustable protective screen with safety switch for greatest possible user protection
- ▶ Generously dimensioned drilling table, solid, precision workmanship, with diagonal T-slots and recirculating coolant duct, reinforcing ribs on rear, rotates through $\pm 90^\circ$ about the column, laterally tilting
- ▶ Coolant unit with coolant tank integrated into base plate
- ▶ Chip filter removes coarse components from the coolant
- ▶ Extremely stable, thick-walled cast-iron column for excellent force absorption
- ▶ Solid base plate with parallel T-slots, precision surface finish
- ▶ Optional footswitch available for toggling between clockwise/anticlockwise run and for thread tapping (Article no. 3050032)



Fig.: DH 35G



Technical specifications, accessories and dimensions

Model	DH 35G
Article no.	3034250
Technical specifications	
Electrical connection	400 V / 3 Ph ~50 Hz
Motor output	1.5 / 2.2 kW
Coolant pump motor	40 W
Drilling performance	
Drilling performance in steel (S235JR)	Ø 35 mm
Continuous drilling performance in steel (S235JR)	Ø 26 mm
Thread tapping steel (S235JR)	M24
Spindle	
Spindle sleeve stroke	125 mm
Spindle seat	MT 4
Throat	285 mm
Automatic spindle sleeve feed	3 speeds: 0.05-0.15 mm/rev
Speeds	
Spindle speeds	75 - 2 000 rpm
Number of speeds	8 speeds
Drilling table	
Drilling table workspace L x W	400 - 420 mm
T-slot size	14 mm, diagonal
Drilling table load bearing capacity	200 kg
Drill table rotation/lateral tilt	360° / ± 90°
Clearance spindle - drilling table	65 - 800 mm
Machine base	
Machine base work area L x W	420 x 395 mm
T-slot size / spacing / count	14 mm / 150 mm / 2
Distance spindle - machine base	max. 1 217 mm
Dimensions	
Column diameter	Ø 115 mm
Length x width x height	860 x 474 x 2 175 mm
Weight	350 kg

Accessories	Article no.
Assortment of clamping tools size 12, 58-parts	3352017
Blank holder 14 mm/M12	3352031
Twist drill bits HSS-CO 5%, 25 parts	3201010
NEW Twist drill bits HSS-CO 5%, 51 parts	3201020
NEW Twist drill bits HSS-CO 5%, 41 parts	3201021
Direct quick release chuck 1 - 16 mm	3050574
Reduction sleeve MT 4 - MT 3	3050664
Reduction sleeve MT 4 - MT 2	3050665
Thermdrill MT 2	3060005
Foot switch	3050032

for thread tapping and toggling clockwise/anticlockwise rotation

› More „Accessories for drills“ from page 60



Machine vices	Article no.
BSI 140	3000214
BSI 200	3000220
BSI-Q 140	3000234
BSI-Q 200	3000240

› Information on the vices on page 67

Dimensions



Scope of supply

- › Quick-action drill chuck 1 - 16 mm
- › Morse taper MT 4/B16

Heavy-duty gearbox drilling machine with thread tapping device

Facts that impress in terms of quality, performance and price

- ▶ Heavy, solid cast design
- ▶ Automatic gearwheel lubrication via oil pump
- ▶ Excellent concentricity thanks to hardened and polished main spindle
- ▶ Thread tapping device.
- ▶ Main switch and motor circuit breaker
- ▶ Adjustable drilling depth stop with millimetre scale
- ▶ Machine lamp integrated in drilling head
- ▶ Precision, generously dimensioned drilling table, solid workmanship, with diagonal T-slots and recirculating coolant duct, reinforcing ribs on rear
- ▶ Integrated push-out tool for easy tool changes
- ▶ Coolant system and chip filter in line with Machinery Directive
- ▶ Thick walled cast column for high force absorption and stability
- ▶ Solid baseplate, large dimensions, extremely stable

OPTIdrill B 40 GSM

- ▶ Electrical spindle sleeve feed

OPTIdrill B 40GSP

- ▶ Manual spindle sleeve feed

Control Cabinet

- › Clear-cut layout
- › Generously dimensioned
- › Certified switches by ABB
- › 24V AC
- › Certified components by Siemens or Schneider



Spindle sleeve feed 2 speeds 0.1/0.2 mm/rev



B 40GSM - electrical

For deep drilling or blind hole drilling, the clutch on the automatic spindle sleeve feed can be released or engaged at any time by pressing the button on the feed handle



B 40GSP - manual



Fig.: B 40GSP

Fig.: B 40GSM



Technical specifications, accessories and dimensions

Model	B 40GSP
Article no.	3034403
Model	B 40GSM
Article no.	3034400
Technical specifications	
Electrical connection	400 V / 3 Ph ~50 Hz
Total rated value	0.85 / 1.5 kW
Coolant pump motor	40 W
Drilling performance	
Drilling performance in steel (S235JR)	Ø 35 mm
Continuous drilling performance in steel (S235JR)	Ø 30 mm
Thread tapping steel (S235JR)	M24
Spindle seat	
Spindle sleeve stroke	180 mm
Spindle seat	MT 4
Throat	350 mm
Spindle sleeve feed	2 speeds, 0.1/0.2 mm/rev
Speeds	
Spindle speeds	50 - 1 450 rpm
Number of speeds	18 speeds
Drilling table	
Workspace drilling table length x width	560 x 560 mm
T-slot size	18 mm, diagonal
Rotating drilling table	± 90°
Clearance spindle - drilling table	max. 780 mm
Drilling table load bearing capacity	250 kg
Machine base	
Machine base work area L x W	510 x 500 mm
T-Slot size / no / distance	18 mm / 2 / 150 mm
Clearance spindle - machine base	max. 1 320 mm
Dimensions	
Column diameter	Ø 150 mm
Length x width x height	935 x 530 x 2 280 mm
Overall weight	500 kg

Scope of supply

- > Quick-action drill chuck 1 - 16 mm
- > Morse taper MT 4/B16

Accessories	Article no.
Assortment of clamping tools size 16, 58-parts	3352019
Blank holder 14 mm/M12	3352031
Quick release chuck direct MT 4 / 1 - 16 mm	3050574
Twist drill bits HSS-CO 5% , 25 parts	3201010
Twist drill bits HSS-CO 5% , 51 parts	3201020
Twist drill bits HSS-CO 5% , 41 parts	3201021
Reduction sleeve MT 4 - MT 3	3050664
> More „Accessories for drills“ from page 60	

Machine vices	Article no.
BSI 100	3000210
BSI 140	3000214
BSI-Q 100	3000230
BSI-Q 140	3000234

> Information on the vices on page 67

Dimensions

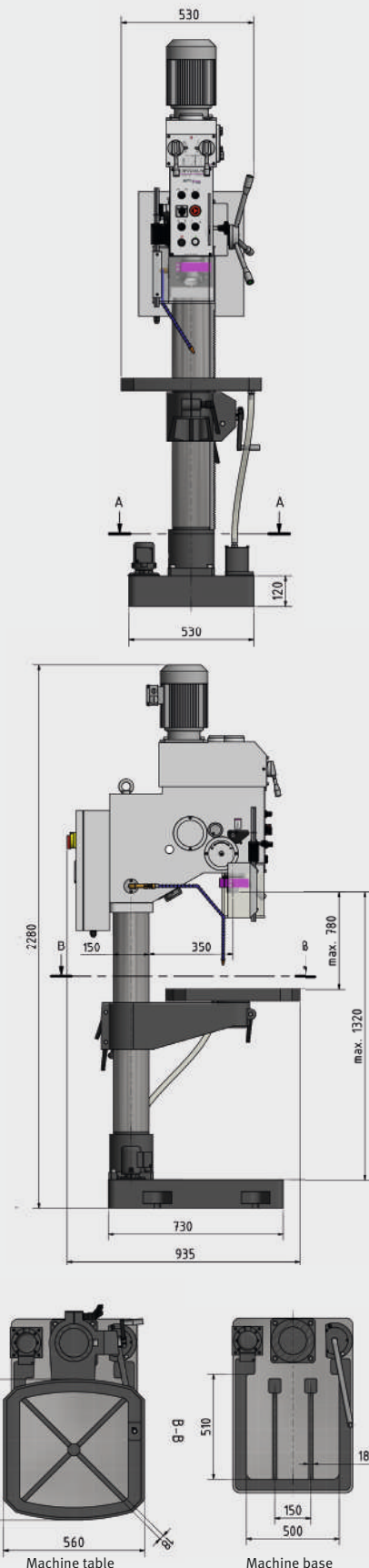

Preface

Drilling

Milling

Turning

Saws

Grinding

Polishing

Lamps

Measuring

Upright drills with Siemens inverter technology and polyamide gearwheels.

With continuously adjustable speed control. Installation of an optional footswitch possible

Facts that impress in terms of quality, performance and price

- ▶ Frequency converter,
- ▶ User-friendly membrane keyboard
- ▶ Digital speed display
- ▶ Thread tapping function
- ▶ Smooth action thanks to polished multi-tooth carrier
- ▶ Excellent concentricity thanks to hardened and polished main spindle
- ▶ Low-maintenance, grease-lubricated gearbox
- ▶ Gearbox with PA6 gearwheels
- ▶ Large speed range
- ▶ User-friendly membrane keyboard
- ▶ Heavy, solid cast design
- ▶ Generously dimensioned, height adjustable protective screen with safety switch for greatest possible user protection
- ▶ Adjustable drilling depth stop with millimetre scale
- ▶ Right-handed/left-handed rotation
- ▶ Thread tapping function

- ▶ Machine lamp integrated in drilling head
- ▶ Integrated push-out tool for easy tool changes
- ▶ Drilling table with precision workmanship, diagonal T-slots, circumferential coolant duct
- ▶ Thick walled cast column for high force absorption and stability
- ▶ Solid baseplate, large dimensions und pronounced ribbing on rear
- ▶ Optional footswitch available for toggling between clockwise/anticlockwise run and for thread tapping (Article no. 3050032)

OPTIdrill DH 32GSV

- ▶ Automatic spindle sleeve feed
- ▶ Coolant system and chip filter in line with Machinery Directive
- ▶ Torque in lowest gear up to 200 Nm

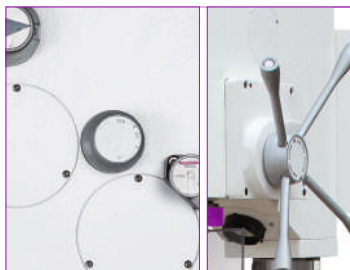

DH 32GSV

Automatic spindle sleeve feed

Activation by pressure switch in spindle sleeve lever. An electromagnetic clutch provides propulsion. The unit is deactivated using the drilling depth stop or by once again pressing the button in the spindle sleeve lever.



Information ssee page 68



Figure: DH 28GSV with optional chuck

Figure: DH 32GSV with optional chuck

Technical specifications, accessories and dimensions

WITH AND WITHOUT VARIO



Model	DH 28GSV	DH 32GSV
Article no.	3034235	3034245
Technical specifications		
Electrical connection	400 V / 3 Ph ~50 Hz	400 V / 3 Ph ~50 Hz
Motor output	1.5 kW	2.2 kW
Coolant pump motor	-	40 W
Drilling performance		
Drilling performance in steel (S235JR)	Ø 26 mm	Ø 30 mm
Continuous drilling performance steel (S235JR)	Ø 23 mm	Ø 26 mm
Thread tapping steel (S235JR)	M 16 x 2 mm	M 16 x 2 mm
Spindle		
Spindle sleeve stroke	127 mm	125 mm
Spindle seat	MT 3	MT 4
Throat	260 mm	285 mm
Automatic spindle sleeve feed	-	2 speeds: 0.05 / 0.1 mm
Speeds		
Spindle speeds	45 - 3 200 rpm	40 - 3 000 rpm
Number of speeds	4 speeds, electronically controlled	
Drilling table		
Drilling table workspace L x W	376 x 394 mm	400 x 420 mm
T-slot size	14 mm, diagonal	14 mm, diagonal
Drilling table load bearing capacity	150 kg	200 kg
Rotating drilling table	360°	360°
Clearance spindle - drilling table	max. 875 mm	max. 820 mm
Machine base		
Machine base work area L x W	350 x 356 mm	420 x 395 mm
T-slot size / spacing / count	14 mm / 120 mm / 2	14 mm / 150 mm / 2
Distance spindle - machine base	max. 1 285 mm	max. 1 270 mm
Dimensions		
Column diameter	Ø 92 mm	Ø 115 mm
Length x width x height	690 x 375 x 2 080 mm	820 x 450 x 2 230 mm
Overall weight	175 kg	304 kg

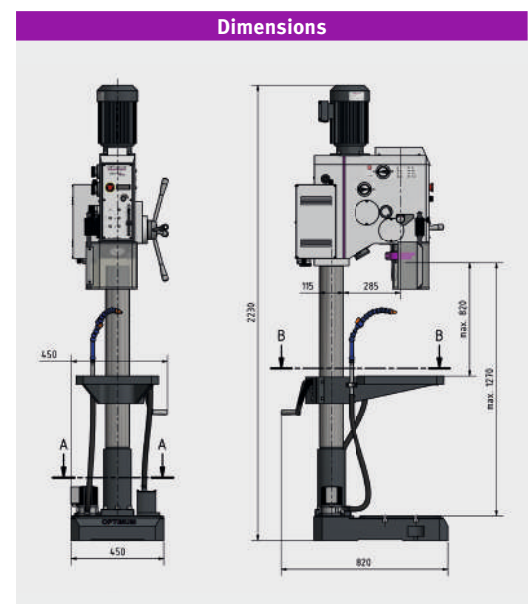
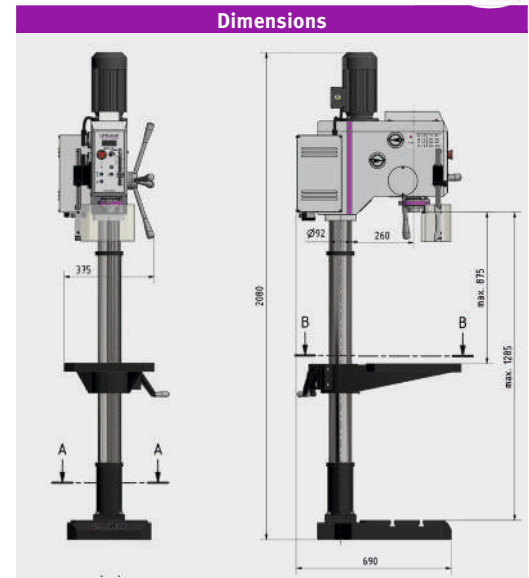

Scope of supply

> Morse taper MK

Accessories	Article no.
Assortment of clamping tools size 12, 58-part	3352017
Quick clamping drill chuck 1 - 8 mm; B16	3050608
Quick clamping drill chuck 1 - 10 mm; B16	3050610
Quick clamping drill chuck 1 - 13 mm; B16	3050623
Quick clamping drill chuck 1 - 16 mm; B16	3050626
Twist drill bits HSS-CO 5%, 25 parts	3201010
Twist drill bits HSS-CO 5%, 51 parts	3201020
Twist drill bits HSS-CO 5%, 41 parts	3201021
Therm드릴 MT 2	3060005
Foot switch	3050032
Functions: Right-handed/left-handed rotation for thread tapping	
> More „Accessories for drills“ from page 60	



Machine vices	Article no.
BMS 120	3000012
BSI 100	3000210
BSI 140	3000214
BSI-Q 100	3000230
BSI-Q 140	3000234

> Information on the vices on page 67

Accessories DH 28GSV	Article no.
Direct quick release chuck 1-16 mm	3050573
Morse taper MT 3/B16	3050660
Reduction sleeve MT 3 - MT 2	3050663
Twist drill HSS / MT 3	3051003
Universal coolant unit	3352002

Accessories DH 32GSV	Article no.
Direct quick release chuck 1-16 mm	3050574
Morse taper MT 4/B16	3050661
Reduction sleeve MT 4 - MT 3	3050664
Reduction sleeve MT 4 - MT 2	3050665

* Important information on transport surcharges and „Operation of machines with frequency converters“ on page 249
The machines comply with DIN EN 55011: class C2.

Bench and Upright drills with polyamide gearwheels. Installation of an optional footswitch possible with DH 32GS

Facts that impress in terms of quality, performance and price

- ▶ Excellent concentricity thanks to hardened and polished main spindle
- ▶ Low-maintenance, grease-lubricated gearbox
- ▶ Gearbox with PA6 gearwheels
- ▶ Large speed range
- ▶ Heavy, solid cast design
- ▶ Generously dimensioned, height adjustable protective screen with safety switch for greatest possible user protection
- ▶ Adjustable drilling depth stop with millimetre scale
- ▶ Right-handed/left-handed rotation
- ▶ Machine lamp integrated in drilling head
- ▶ Integrated push-out tool for easy tool changes
- ▶ Drilling table with precision workmanship, diagonal T-slots, circumferential coolant duct
- ▶ Thick walled cast column for high force absorption and stability
- ▶ Solid baseplate, large dimensions und pronounced ribbing on rear

OPTIdrill DH 32GS

- ▶ Thread tapping function
- ▶ Automatic spindle sleeve feed
- ▶ Coolant system and chip filter in line with Machinery Directive
- ▶ Optional footswitch available for toggling between clockwise/anticlockwise run and for thread tapping (Article no. 3050032)

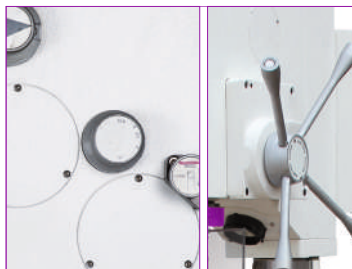

OPTIdrill DH 32GS Automatic spindle sleeve feed

Activation by pressure switch in spindle sleeve lever. An electromagnetic clutch provides propulsion. The unit is deactivated using the drilling depth stop or by once again pressing the button in the spindle sleeve lever.

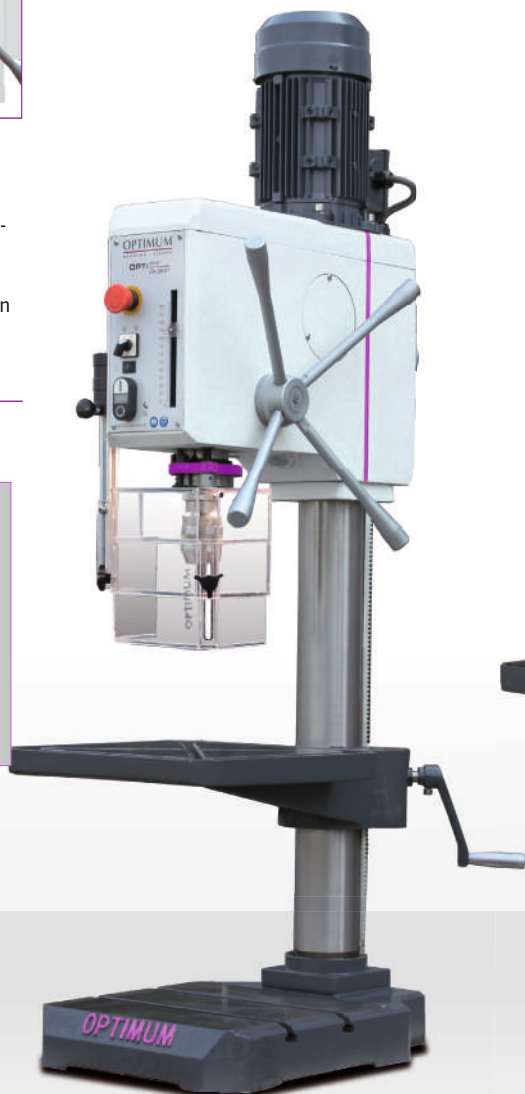

Figure: DH 26GT with optional chuck



Figure: DH 32GS with optional chuck



Technical data and accessories

Model	DH 26GT	DH 28GS	DH 32GS
Article no.	3034220	3034230	3034240
Technical specifications			
Electrical connection	400 V / 3 Ph ~50 Hz	400 V / 3 Ph ~50 Hz	400 V / 3 Ph ~50 Hz
Motor output	1.1 / 1.5 kW	1.1 / 1.5 kW	1.5 / 2.2 kW
Coolant pump motor	-	-	40 W
Drilling performance			
Drilling performance in steel (S235JR)	Ø 24 mm	Ø 26 mm	Ø 30 mm
Continuous drilling performance steel (S235JR)	Ø 21 mm	Ø 23 mm	Ø 26 mm
Thread tapping steel (S235JR)	-	-	M16 x 2 mm
Spindle			
Spindle sleeve stroke	127 mm	127 mm	125 mm
Spindle seat	MT 3	MT 3	MT 4
Throat	235 mm	260 mm	285 mm
Automatic spindle sleeve feed	-	-	2 speeds: 0.05 mm / 0.1 mm
Speeds			
Spindle speeds	75 - 2 900 rpm	75 - 2 900 rpm	75 - 2 000 rpm
Number of speeds	8 speeds	8 speeds	8 speeds
Drilling table			
Workspace drilling table length x width	380 x 380 mm	376 x 394 mm	400 x 420 mm
T-slot size	14 mm, diagonal	14 mm, diagonal	14 mm, diagonal
Drilling table load bearing capacity	120 kg	150 kg	200 kg
Rotating drilling table	360°	360°	360°
Clearance spindle - drilling table	max. 450 mm	max. 875 mm	max. 820 mm
Machine base			
Machine base work area L x W	350 x 356 mm	350 x 356 mm	450 x 395 mm
T-slot size / spacing / count	14 mm / 120 mm / 2	14 mm / 120 mm / 2	14 mm / 150 mm / 2
Distance spindle - machine base	max. 610 mm	max. 1 285 mm	max. 1 270 mm
Dimensions			
Column diameter	Ø 92 mm	Ø 92 mm	Ø 115 mm
Length x width x height	610 x 380 x 1 430 mm	640 x 376 x 2 080 mm	725 x 450 x 2 200 mm
Overall weight	158 kg	175 kg	312 kg

Scope of supply

> Morse taper MK

Accessories	Article no.
Assortment of clamping tools size 12, 58-parts	3352017
Quick clamping drill chuck 1 - 8 mm; B16	3050608
Quick clamping drill chuck 1 - 10 mm; B16	3050610
Quick clamping drill chuck 1 - 13 mm; B16	3050623
Quick clamping drill chuck 1 - 16 mm; B16	3050626
Twist drill bits HSS-CO 5%, 25 parts	3201010
Twist drill bits HSS-CO 5%, 51 parts	3201020
Twist drill bits HSS-CO 5%, 41 parts	3201021
Thermdrill MT 2	3060005

> More „Accessories for drills“ from page 60

Machine vices	Article no.
BMS 120	3000012
BSI 100	3000210
BSI 140	3000214
BSI-Q 100	3000230
BSI-Q 140	3000234

> Information on the vises on page 67

Accessories DH 26GT / DH 28GS	Article no.
Direct quick release chuck 1-16 mm	3050573
Morse taper MT 3/B16	3050660
Reduction sleeve MT 3 - MT 2	3050663
Twist drill HSS / MT 3	3051003
Thread tapping chuck M3 - M12	3050705
Thread tapping chuck M8 - M20	3050706
Universal coolant unit	3352002

Accessories DH 32GS	Article no.
Direct quick release chuck 1-16 mm	3050574
Morse taper MT 4/B16	3050661
Reduction sleeve MT 4 - MT 3	3050664
Reduction sleeve MT 4 - MT 2	3050665
Foot switch	3050032

Functions:

- > Thread tapping
- > Clockwise/anti-clockwise change over switch



Column gear drilling machine with cross table. The versatile machine for milling and drilling

Facts that impress in terms of quality, performance and price

- ▶ Heavy, solid cast design
- ▶ Smooth action due to polished gearwheels running in an oil sump
- ▶ Large speed range of 95 - 3 200 rpm
- ▶ Two-stage industrial quality electric motor
- ▶ Generously dimensioned, Solid cross table with precision surface finish, adjustable via 3 hand wheels, includes integrated length scale
- ▶ Adjustable end stops on the cross table
- ▶ Gear head and table are height adjustable
- ▶ Table guideways precisely adjustable via V-ledges
- ▶ Solid baseplate with precision surface finish can be used as a workspace for particularly high workpieces by swivelling out the cross table
- ▶ Right-handed/left-handed rotation
- ▶ Gear head pivots through $\pm 60^\circ$
- ▶ Drilling depth stop
- ▶ Thread tapping function

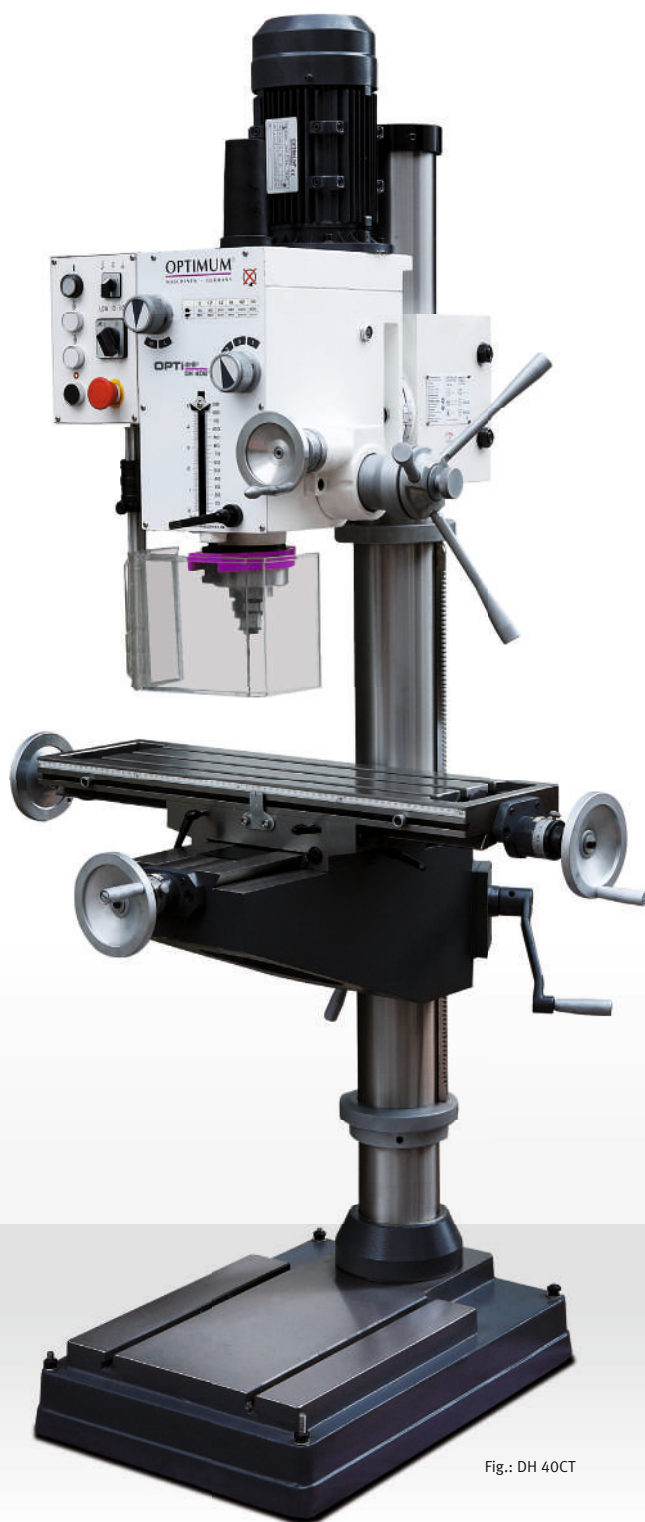

Fig.: DH 40CT



Technical specifications, accessories and dimensions

Model	DH 40CT
Article no.	3034350
Technical data	
Electrical connection	400 V / 3 Ph ~ 50 Hz
Motor output, 2 stages	1.1 / 1.5 kW
Drilling/milling output	
Drilling performance in steel (S235JR)	Ø 32 mm
Continuous drilling performance in steel (S235JR)	Ø 25 mm
Max. sensor head size	Ø 76 mm
Max. shaft milling cutter size	Ø 25 mm
Thread tapping steel (S235JR)	M16
Spindle	
Spindle sleeve stroke	120 mm
Spindle seat	MT 4
Throat	280 mm
Spindle sleeve diameter	75 mm
Draw-in rod	M16
Drilling/milling head	
Swivel range	± 45°
Spindle speeds	95 - 3 200 rpm
Speeds	2 x 6 speeds
Cross table	
Length x width	730 x 210 mm
T-Slot size / no / distance	14 mm / 3 / 63 mm
Load bearing capacity	50 kg
Clearance spindle to cross table	max. 600 mm
X-axis travel stroke manual	480 mm
Y-axis travel stroke manual	180 mm
Z-axis travel stroke manual	560 mm
Machine base	
Machine base work area L x W	495 x 375 mm
T-slot size / spacing / count	14 mm / 230 mm / 2
Distance spindle - machine base	920 - 1 180 mm
Dimensions	
Column diameter	Ø 115 mm
Length x width x height	1 060 x 745 x 2 090 mm
Weight	340 kg

Accessories	Article no.
Assortment of clamping tools size 12, 58-parts	3352017
Hold-down device 14 mm/M12	3352031
Parallel shim set, 20-part	3354001
Height-adjustable tailstock RST 1	3356155
Horizontal-vertical rotary indexing table RT 150	3356150
Universal coolant unit	3352002

› More „Accessories for drills“ from page 60

Machine vices	Article no.
BMS 120	3000012
BSI 100	3000210
BSI 140	3000214
BSI-Q 100	3000230
BSI-Q 140	3000234

› Information on the vices on page 67

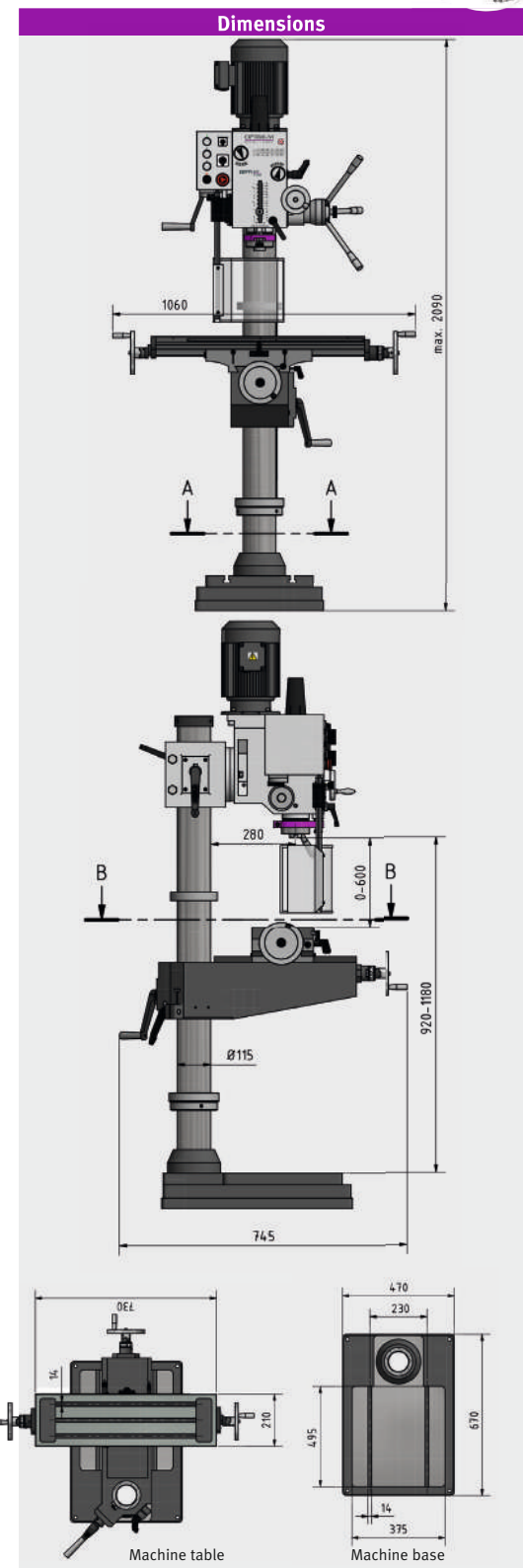

Scope of supply

- › Key type drill chuck 1 - 13 mm / B18
- › T-slot nuts
- › Push-out tools large and small
- › Reduction sleeve MT 4 - MT 3
- › Arbor for drill chuck MT 4 / B16
- › Operating tool

Preface

Drilling

Milling

Turning

Saws

Grinding

Polishing

Lamps

Measuring

Universal column gearbox drill with 12 speeds for milling and drilling.

DH 40GP additionally with automatic spindle sleeve feed

Facts that impress in terms of quality, performance and price

- ▶ Heavy, solid cast design
- ▶ Smooth action due to polished gearwheels running in an oil sump
- ▶ Two-stage industrial electric motor
- ▶ Thread tapping function
- ▶ Gear head and table are height adjustable
- ▶ Large speed range from 95 - 3 200 rpm thanks to 12 switchable speeds
- ▶ Large drilling table, solid, precision workmanship, with diagonal T-slots and recirculating coolant duct, reinforcing ribs on rear side, double clamping
- ▶ Drilling depth stop
- ▶ Height-adjustable chuck protection with micro switch for greatest possible protection of the user
- ▶ Coupling for switching over from manual rough to manual fine feed
- ▶ Thick walled cast column for high force absorption and stability
- ▶ Solid baseplate with precision surface finish can be used as a workspace for particularly high workpieces by swivelling out the drilling table

OPTIdrill DH 40GP

- ▶ Automatic spindle sleeve feed

DH 40GP

Automatic spindle sleeve feed

Drilling depth stop adjustable within range of 0-90 mm. The feed is automatically switched off after reaching the preset drilling depth and turned back to its original position by the spring force of the return spring



Fig.:DH 40G

Fig.: DH 40GP



Technical specifications, accessories and dimensions

Model	DH 40G	DH 40GP
Article no.	3034355	3034360
Technical specifications		
Electrical connection	400 V / 3 Ph ~50 Hz	
Motor output	1.1 / 1.5 kW	
Drilling performance		
Drilling performance in steel (S235JR)	Ø 32 mm	
Continuous drilling performance in steel (S235JR)	Ø 25 mm	
Thread tapping steel (S235JR)	M16	
Spindle		
Spindle sleeve stroke	120 mm	
Spindle sleeve diameter	75 mm	
Spindle seat	MT 4	
Throat	280 mm	
Automatic spindle sleeve feed	3 speeds: 0.1 - 0.26 mm/rev	
Drilling head pivots/rotates	± 45° / 360°	
Drilling head height adjustment	0 - 265 mm	
Speeds		
Spindle speeds	95 - 3 200 rpm	
Speeds	2 x 6 speeds	
Drilling table		
Length x width	500 x 460 mm	
T-slot size	14 mm, diagonal	
Load bearing capacity	50 kg	
Rotation/lateral tilt	360° / ± 90°	
Clearance spindle - drilling table	max. 715 mm	
Machine base		
Machine base work area L x W	650 - 450 mm	
T-slot size / spacing / count	14 mm / 230 mm / 2	
Distance spindle - machine base	max. 1 180 mm	
Dimensions		
Column diameter	Ø 115 mm	
Length x width x height	595 x 700 x 2 050 mm	
Weight	320 kg	335 kg

Accessories	Article no.
Assortment of clamping tools size 12, 58-parts	3352017
Twist drill bits HSS-CO 5%, 25 parts	3201010
NEW Twist drill bits HSS-CO 5%, 51 parts	3201020
NEW Twist drill bits HSS-CO 5%, 41 parts	3201021
Universal coolant unit	3352002
Coolant mist lubricator MMC 1 with magnetic holder	3356663
Direct quick release chuck 1 - 16 mm	3050574
Collet chuck set MT 4/ ER 32	3352094
Reduction sleeve MT 4 - MT 3	3050664
Morse taper MT 4/B16	3050661

Machine vices	Article no.
BMS 120	3000012
BSI 140	3000214
BSI 200	3000220
BSI-Q 140	3000234
BSI-Q 200	3000240

› Information on the vises on page 67

Dimensions DH 40G

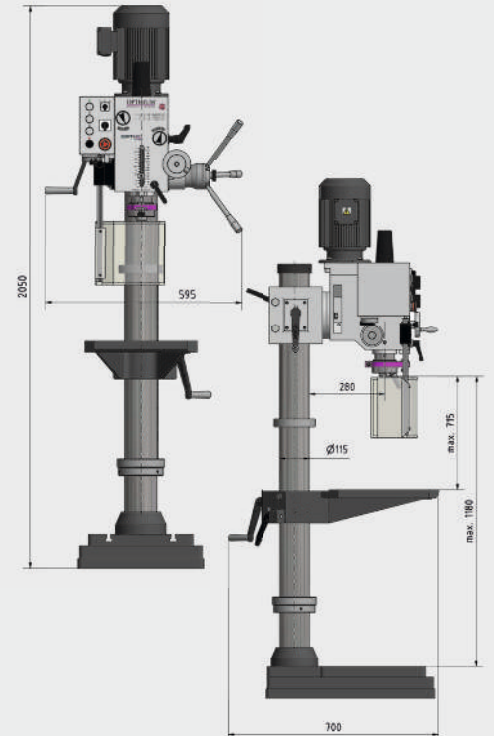

Dimensions DH 40GP

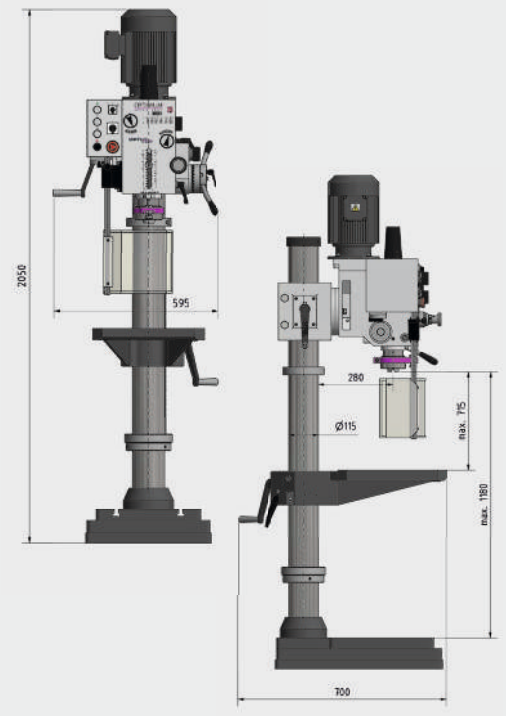

Scope of supply

- › Quick-action drill chuck 1 - 13 mm
- › Morse taper MT 4/B16
- › Tie rod M16
- › Adapter MT 4 - MT 3
- › Operating tool

Preface

Drilling

Milling

Turning

Saws

Grinding

Polishing

Lamps

Measuring

Bench and Upright drills with continuous, mechanical belt gear.
Quick speed adjustment using a lever **BERGES**



Facts that impress in terms of quality, performance and price

- ▶ Smooth action powerful electric motor
- ▶ Two speeds
- ▶ Right-handed/left-handed rotation
- ▶ V-belt cover with safety switch
- ▶ Digital speed display integrated in housing
- ▶ Guaranteed concentricity guaranteed to be less than 0.015 mm measured in the drilling spindle sleeve
- ▶ Height adjustable chuck guard with micro switch for greatest possible protection of the user
- ▶ Machine lamp integrated into drilling head
- ▶ Drilling spindle with precision ball bearings
- ▶ Premium quick clamping chuck as standard
- ▶ Precision, generously dimensioned drilling table, solid workmanship, with diagonal T-slots, rotating through 360°, recirculating coolant duct

- ▶ Thick walled cast column for high force absorption and stability
- ▶ Solid baseplate with with pronounced ribbing on rear
- ▶ The baseplate can be used as a workspace for particularly high workpieces by swivelling out the drilling table

As of DH 28BV

- ▶ Easy tool changes through integrated push-out tool
- ▶ Spindle sleeve lever made of steel

DH 40BV

- ▶ Digital depth sensor
- ▶ Reduction gearbox enables far higher torque



Continuous mechanical gearbox

- › Extremely reliable through manual speed control
- › Powerful, smooth action
- › Durable wide groove v-belt
- › Speed change also possible while machine is running
- › Permanent optimal motor efficiency
- › DH 40BV- with reduction gearbox



Speed setting

- › Quicker speed adjustment using a lever



Information see page 68



Figure: DH 24BV



Figure: DH 40BV



Technical data and accessories

Model	DH 24BV	DH 28BV	DH 40BV
Article no.	3020420	3020430	3020450
Technical specifications			
Electrical connection	400 V / 3 Ph ~50 Hz	400 V / 3 Ph ~50 Hz	400 V / 3 Ph ~50 Hz
Motor output	0.85 / 1.5 kW	0.85 / 1.5 kW	1.5 / 2.2 kW
Drilling performance			
Drilling performance in steel (S235JR)	Ø 24 mm	Ø 28 mm	Ø 40 mm
Continuous drilling performance in steel (S235JR)	Ø 20 mm	Ø 24 mm	Ø 32 mm
Spindle			
Spindle sleeve stroke	85 mm	105 mm	160 mm
Spindle seat	MT 2	MT 3	MT 4
Throat	165 mm	200 mm	285 mm
Speeds			
Spindle speeds	300 - 4 000 rpm	300 - 4 000 rpm	150 - 2 000 rpm
Number of speeds	2 speed motor, manual	2 speed motor, manual	2 speed motor, manual
Drilling table			
Drilling table workspace L x W	280 x 300 mm	340 x 360 mm	420 x 400 mm
T-slot size	14 mm, diagonal	14 mm, diagonal	14 mm, diagonal
Clearance spindle - drilling table	max. 515 mm	max. 860 mm	max. 790 mm
Machine base			
Machine base work area L x W	280 x 260 mm	320 x 320 mm	390 x 400 mm
T-slot size / spacing / count	14 mm / 120 mm / 2	14 mm / 120 mm / 2	14 mm / 150 mm / 2
Rotating drilling table	360°	360°	360°
Distance spindle - machine base	max. 681 mm	max. 1 285 mm	max. 1 275 mm
Dimensions			
Column diameter	Ø 80 mm	Ø 92 mm	Ø 115 mm
Length x width x height	675 x 555 x 1 025 mm	755 x 550 x 1 745 mm	920 x 680 x 1 895 mm
Weight	115 kg	152 kg	275 kg

Scope of supply

- › Quick-action drill chuck 1 - 16 mm
- › Morse taper MK
- › T-slot nuts

Accessories	Article no.
Assortment of clamping tools size 12	3352017
Hold-down device 14 mm/M12	3352031
Twist drill bits HSS-CO 5%, 25 parts	3201010
NEW Twist drill bits HSS-CO 5%, 51 parts	3201020
NEW Twist drill bits HSS-CO 5%, 41 parts	3201021
Quick clamping drill chuck 1 - 8 mm; B16	3050608
Quick clamping drill chuck 1 - 10 mm; B16	3050610
Quick clamping drill chuck 1 - 13 mm; B16	3050623
Quick clamping drill chuck 1 - 16 mm; B16	3050626
Thread tapping chuck M3 - M12	3050705
Thread tapping chuck M8 - M20	3050706
Universal coolant unit	3352002
Coolant mist lubricator MMC 1 with magnetic holder	3356663
Coolant hose KMS 2	3356660

› More „Accessories for drills“ from page 60

Machine vices	Article no.
BMS 120	3000012
BSI 100	3000210
BSI-Q 100	3000230

› Information on the vises on page 67

DH 24BV accessories	Article no.
Direct quick release chuck 1 - 16 mm	3050571
Direct quick release chuck 1 - 13 mm	3050572
Collet chuck set MT 2/ ER 25	3352052
Morse taper MT 2/B16	3050659
Twist drill bit HSS / MT 2, 9 parts	3051002

DH 28BV ACCESSORIES	Article no.
Direct quick release chuck 1 - 16 mm	3050573
Collet chuck set MT 3/ ER 32	3352093
Reduction sleeve MT 3 - MT 2	3050663
Reduction sleeve MT 3 - MT 2	3350313
Morse taper MT 3/B16	3050660
Twist drill bit HSS / MT 3, 9 parts	3051003

DH 40BV accessories	Article no.
Direct quick release chuck 1 - 16 mm	3050574
Collet chuck set MT 4/ ER 32	3352094
Reduction sleeve MT 4 - MT 3	3050664
Reduction sleeve MT 4 - MT 3	3350314
Morse taper MT 4/B16	3050661

Rugged bench and Upright drills with powerful OPTIMUM Brushless drive, electronic speed control

Facts that impress in terms of quality, performance and price

- ▶ Powerful brushless drive with particularly smooth action and high performance with almost constant torque over the entire speed range
- ▶ Best possible force transmission thanks to aluminium pulleys in combination with GATES quality toothed belts
- ▶ Smooth action thanks to polished multi-tooth carrier
- ▶ Guaranteed concentricity guaranteed to be less than 0.015 mm measured in the drilling spindle sleeve
- ▶ Separate emergency stop button
- ▶ Digital speed display integrated in housing
- ▶ Premium OPTIMUM quick clamping chuck as standard
- ▶ Generously dimensioned, height adjustable protective screen with safety switch for greatest possible user protection
- ▶ Single-piece, pressure cast aluminium spindle sleeve lever (B 24HV with Softgrip handles)
- ▶ Drilling depth stop
- ▶ V-belt cover with safety switch
- ▶ V-belt tensioning device

- ▶ Right-handed/left-handed rotation
- ▶ Machine lamp integrated in drilling head
- ▶ Precision workmanship; rugged drilling table with diagonal T-slots, 360° rotation and all-around cooling water channel
- ▶ Thick walled cast column for high force absorption and stability
- ▶ Solid baseplate, large dimensions und pronounced ribbing on rear

As of B 28HV

- ▶ Spindle sleeve lever made of steel
- ▶ Coolant system
- ▶ Chip filter in line with Machinery Directive
- ▶ Easy tool changes through integrated push-out tool

B 34HV

- ▶ Spindle sleeve stroke 160 mm
- ▶ Thread tapping function
- ▶ Digital depth sensor



B 34HV - Operating modes

"auto" operating mode

- › Motor runs automatically after lever movement
- › Stops again in original position
- › Start and stop pushbuttons do not need to be actuated for repetitive drilling tasks

"Thread tapping" operating mode

- › The motor is activated by moving the handle down
- › The direction of rotation is changed by the limit switch on the adjustable drilling depth stop

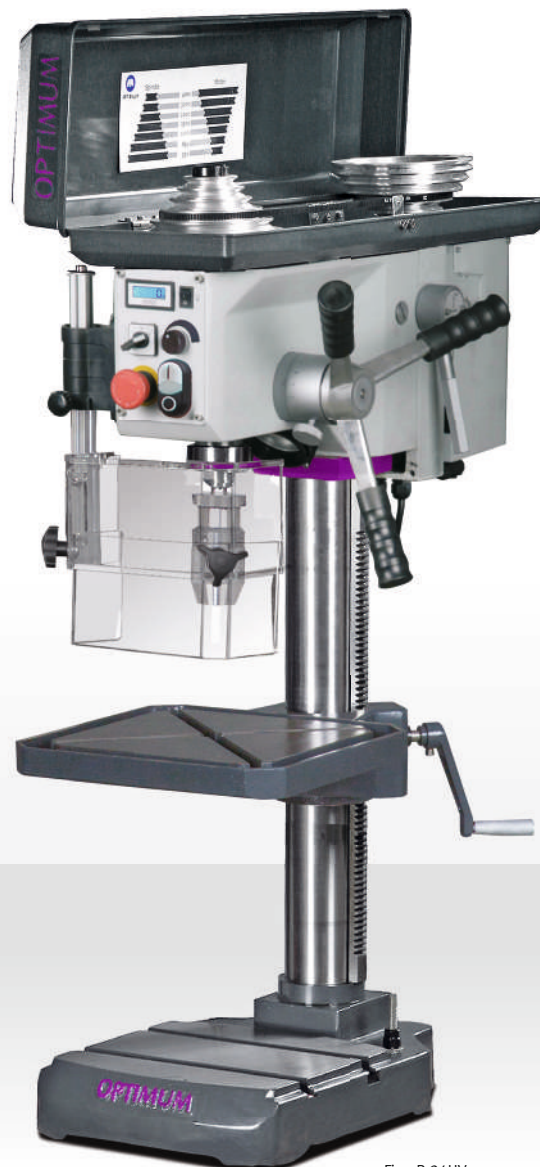

Fig.: B 24HV



Technical data and accessories

Model	B 24HV	B 28HV	B 34HV
Article no.	3020245	3020285	3020335
Technical specifications			
Electrical connection	230 V / 1 Ph ~50 Hz	230 V / 1 Ph ~50 Hz	230 V / 1 Ph ~50 Hz
Motor output	1.5 kW	1.5 kW	2.2 kW
Coolant pump motor	-	40 W	40 W
Drilling performance			
Drilling performance in steel (S235JR)	Ø 24 mm	Ø 28 mm	Ø 34 mm
Continuous drilling performance in steel (S235JR)	Ø 20 mm	Ø 24 mm	Ø 26 mm
Thread tapping steel (S235JR)	-	-	M 16 x 2 mm
Spindle			
Spindle sleeve stroke	85 mm	105 mm	160 mm
Spindle seat	MT 2	MT 3	MT 4
Throat	165 mm	200 mm	285 mm
Speeds			
Spindle speeds	100 - 5 950 rpm	35 - 5 600 rpm	40 - 5 000 rpm
Number of speeds	4 speeds Electronic speed control	12 speeds Electronic speed control	9 speeds Electronic speed control
Drilling table			
Drilling table workspace L x W	280 x 300 mm	340 x 360 mm	420 x 400 mm
T-slot size	14 mm, diagonal	14 mm, diagonal	14 mm, diagonal
Rotating drilling table	360°	360°	360°
Clearance spindle - drilling table	max. 515 mm	max. 860 mm	max. 790 mm
Machine base			
Machine base work area L x W	280 x 260 mm	320 x 320 mm	390 x 390 mm
T-slot size / spacing / count	14 mm / 120 mm / 2	14 mm / 120 mm / 2	14 mm / 150 mm / 2
Rotating drilling table	360°	360°	360°
Distance spindle - machine base	max. 590 mm	max. 1 285 mm	max. 1 275 mm
Dimensions			
Column diameter	Ø 80 mm	Ø 92 mm	Ø 115 mm
Length x width x height	665 x 434 x 998 mm	701 x 474 x 1 755 mm	918 x 595 x 1 930 mm
Weight	96 kg	166 kg	275 kg

Accessories	Article no.
Assortment of clamping tools size 12	3352017
Hold-down device 14 mm/M12	3352031
Twist drill bits HSS-CO 5%, 25 parts	3201010
NEW Twist drill bits HSS-CO 5%, 51 parts	3201020
NEW Twist drill bits HSS-CO 5%, 41 parts	3201021
Quick clamping drill chuck 1 - 8 mm; B16	3050608
Quick clamping drill chuck 1 - 10 mm; B16	3050610
Quick clamping drill chuck 1 - 13 mm; B16	3050623
Quick clamping drill chuck 1 - 16 mm; B16	3050626

> More „Accessories for drills“ from page 60

Machine vices	Article no.
BMS 100	3000010
BMS 120	3000012
BSI 100	3000210
BSI 140	3000214
BSI-Q 100	3000230
BSI-Q 140	3000234

> Information on the vices on page 67

Accessories B 24HV	Article no.
Direct quick release chuck 1 - 16 mm	3050571
Direct quick release chuck 1 - 13 mm	3050572
Collet chuck set MT 2/ ER 25	3352052
Morse taper MT 2/B16	3050659
Twist drill bit HSS / MT 2, 9 parts	3051002
Thread tapping chuck MT 2	3050702
Universal coolant unit	3352002
Accessories B 28HV	Article no.
Direct quick release chuck 1 - 16 mm	3050573
Collet chuck set MT 3/ ER 32	3352093
Reduction sleeve MT 3 - MT 2	3050663
Reduction sleeve MT 3 - MT 2	3350313
Morse taper MT 3/B16	3050660
Twist drill bit HSS / MT 3, 9 parts	3051003
Thread tapping chuck MT 3	3050705
Accessories B 34HV	Article no.
Direct quick release chuck 1 - 16 mm	3050574
Collet chuck set MT 4/ ER 32	3352094
Reduction sleeve MT 4 - MT 3	3050664
Reduction sleeve MT 4 - MT 3	3350314
Morse taper MT 4/B16	3050661
Thread tapping chuck MT 4	3050709

* Important information on the transport packaging flat rate and surcharge and „Operation of machines with frequency converters“ on page 249
**The machines comply with DIN EN 55011: class C2.

Rugged table drilling machine with powerful OPTIMUM brushless drive.

Machine highlight - menu-controlled operation of the drilling/thread tapping operation modes

Facts that impress in terms of quality, performance and price

- ▶ Smooth action and powerful brushless drive
- ▶ Best possible force transmission thanks to aluminium pulleys in combination with GATES quality toothed belts
- ▶ Smooth action thanks to polished multi-tooth carrier
- ▶ Guaranteed concentricity guaranteed to be less than 0.015 mm measured in the drilling spindle sleeve
- ▶ Drilling spindle with precision ball bearings
- ▶ Membrane keyboard; soiling and water resistant, easy to clean
- ▶ Premium OPTIMUM quick clamping chuck as standard
- ▶ Separate emergency stop button
- ▶ Precise workmanship; stable drilling table with diagonal T-slots, 360° rotation
- ▶ Circumferential coolant channel surrounding the drilling table
- ▶ Generously dimensioned, height adjustable protective screen with safety switch for greatest possible user protection
- ▶ Drilling depth stop
- ▶ V-belt cover with safety switch
- ▶ V-belt tensioning device
- ▶ Solid baseplate with, pronounced ribbing on rear



Information see page 68



Powerful brushless drive

- › Particularly smooth action
- › Extremely powerful
- › Virtually constant torque over the entire speed range

OLED display

- › Drilling
- › Thread tapping
- › Workpiece thickness selection



- › Spindle speed
- › Depth display (target/actual)



Figure: DH 18V



Technical specifications, accessories and dimensions

Model	DH 18V
Article no.	3020220
Technical specifications	
Electrical connection	230 V / 1 Ph ~50 Hz
Motor output	1.5 kW
Drilling performance	
Drilling performance in steel (S235JR)	Ø 18 mm
Continuous drilling performance in steel (S235JR)	Ø 16 mm
Thread tapping steel (S235JR)	M10
Spindle	
Spindle sleeve stroke	65 mm
Spindle seat	MT 2
Throat	132 mm
Speeds	
Spindle speeds	100 - 6 000 rpm
Number of speeds	5 speeds Electronic speed control
Drilling table	
Drilling table workspace L x W	230 x 245 mm
T-slot size	12 mm, diagonal
Rotating drilling table	360°
Clearance spindle - drilling table	max. 370 mm
Machine base	
Machine base work area L x W	220 x 240 mm
T-slot size / spacing / count	12 mm / 80 mm / 2
Distance spindle - machine base	max. 485 mm
Dimensions	
Column diameter	Ø 60 mm
Length x width x height	445 x 552 x 850 mm
Weight	64 kg

Accessories	Article no.
Quick release chuck direct MT 2 / 1 - 16 mm	3050571
Quick release chuck direct MT 2 / 1 - 13 mm	3050572
Morse taper MT 2/B16	3050659
Twist drill bit HSS / MT 2, 9 parts	3051002
Assortment of clamping tools size 10, 58-parts	3352016
Taper drill punch MSP1	3050636
Universal coolant unit 230 V	3352002
Coolant mist lubricator MMC 1 with magnetic holder	3356663
Coolant hose KMS 2	3356660
Twist drill bits HSS-CO 5%, 25 parts	3201010
NEW Twist drill bits HSS-CO 5%, 51 parts	3201020
NEW Twist drill bits HSS-CO 5%, 41 parts	3201021
NEW Thread tapping chuck 6 inserts, sizes M3 - M12	3050702
Therm드릴 MT 2	3060005
Machine chassis	3353000
Information „Machine bases“ on page 131	
› More „Accessories for drills“ from page 60	

Machine vices	Article no.
BMS 100	3000010
BMS 120	3000012
BSI 100	3000210
BSI-Q 100	3000230
› Information on the vices on page 67	

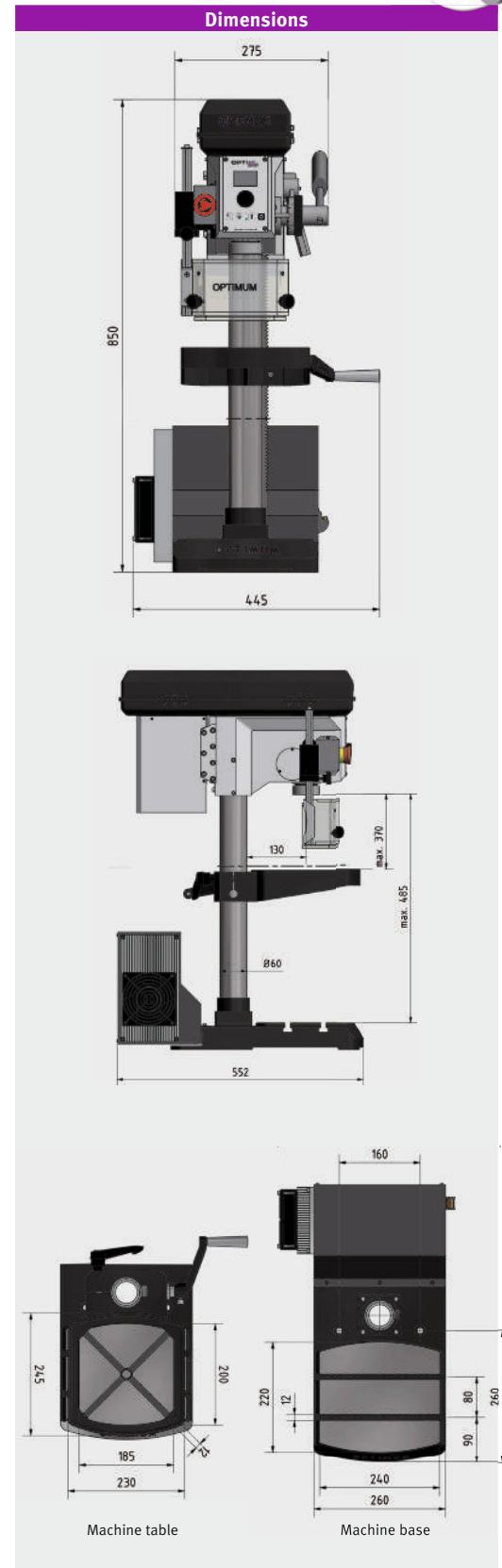

Scope of supply

- › Quick clamping drill chuck 1 - 13 mm
- › Morse taper MT 2
- › T-slot nuts

Rugged bench/Upright drills with V-belt drive

Facts that impress in terms of quality, performance and price

- ▶ Smooth, powerful industrial electric motor
- ▶ Separate emergency stop button
- ▶ Rugged cast column
- ▶ Drilling depth stop
- ▶ Precision machined drilling table with diagonal T-slots and all-around cooling water channel
- ▶ V-belt cover with safety switch
- ▶ V-belt quick tensioning device
- ▶ Solid, generously dimensioned baseplate with T-slots, pronounced ribbing on rear
- ▶ The baseplate can be used for particularly high workpieces by swivelling out the drilling table
- ▶ Guaranteed concentricity better than 0.015 mm measured in the drilling spindle sleeve
- ▶ Drill spindle with precision ball bearings
- ▶ Premium Optimum quick clamping chuck as standard equipment
- ▶ Generously dimensioned, height adjustable protective screen with safety switch

As of B 24H

- ▶ Machine lamp

As of B 24H/400V

- ▶ Right-handed/left-handed rotation

As of B 28H

- ▶ Easy tool changes through integrated push-out tool
- ▶ Spindle sleeve lever made of steel

B 34H

- ▶ Digital depth sensor
- ▶ Digital speed display



Belt drive

- › Smooth action thanks to polished multi-tooth carrier
- › Best possible force transmission thanks to aluminium pulleys in combination with GATES quality toothed belts



Fig.: B 16H

Fig.: B 24H

Fig.: B 28H

Fig.: B 34H



Technical data and accessories

Model	B 16H	B 24H	B 28H	B 34H
Article no. (230 V)	-	3020241	-	-
Article no. (400 V)	3020217	3020243	3020283	3020333
Technical specifications				
Electrical connection	400 V / 3 Ph ~50 Hz	230 V/1 Ph - 400 V/3 Ph	400 V / 3 Ph ~50 Hz	400 V / 3 Ph ~50 Hz
Motor output	550 W	850 W	850 W	1.5-2.2 kW
Drilling performance				
Drilling performance in steel (S235JR)	Ø 13 mm	Ø 24 mm	Ø 28 mm	Ø 34 mm
Continuous drilling performance in steel (S235JR)	Ø 11 mm	Ø 20 mm	Ø 24 mm	Ø 26 mm
Spindle				
Spindle sleeve stroke	65 mm	85 mm	105 mm	160 mm
Spindle seat	MT 2	MT 2	MT 3	MT 4
Throat	130 mm	165 mm	200 mm	285 mm
Speeds				
Spindle speeds	450 - 3 500 rpm	350 - 4 000 rpm	120 - 4 000 rpm	145 - 4 800 rpm
Number of speeds	5 speeds	7 speeds	16 speeds	2 x 9 speeds
Drilling table				
Drilling table workspace L x W	230 x 245 mm	280 x 300 mm	340 x 360 mm	420 x 400 mm
Diagonal T-slot size	12 mm	14 mm	14 mm	14 mm
Rotating drilling table	360°	360°	360°	360°
Clearance spindle - drilling table	max. 370 mm	max. 515 mm	max. 860 mm	max. 790 mm
Machine base				
Machine base work area L x W	200 x 240 mm	280 x 260 mm	320 x 320 mm	390 x 390 mm
T-slot size / spacing / count	12 mm / 80 mm / 2	14 mm / 120 mm / 2	14 mm / 120 mm / 2	14 mm / 150 mm / 2
Distance spindle - machine base	max. 495 mm	max. 590 mm	max. 1 285 mm	max. 1 275 mm
Dimensions				
Column diameter	Ø 60 mm	Ø 80 mm	Ø 92 mm	Ø 115 mm
Length x width x height	549 x 300 x 848 mm	665 x 434 x 998 mm	698 x 449 x 1 721 mm	918 x 585 x 1 895 mm
Weight	54 kg	92 kg	166 kg	260 kg

Scope of supply
> Quick clamping drill chuck 1 – 13 mm (B 16H)
> Quick clamping drill chuck 1 – 16 mm (as of B 24H)
> Morse cone
> T-slot nuts

Accessories	Article no.
Twist drill bits HSS-CO 5%, 25 parts	3201010
Twist drill bits HSS-CO 5%, 51 parts	3201020
Twist drill bits HSS-CO 5%, 41 parts	3201021
Universal coolant unit	3352002
Coolant mist lubricator MMC 1 with magnetic holder	3356663
Coolant hose KMS 2	3356660
> More „Accessories for drills“ from page 60	

Machine vices	Article no.
BMS 100	3000010
BMS 120	3000012
BSI 100	3000210
BSI 140	3000214
BSI-Q 100	3000230
BSI-Q 140	3000234
> Information on the vises on page 67	

Accessories B 16H / B 24H	Article no.
Quick release chuck direct MT 2 1-16 mm	3050571
Quick release chuck direct MT 2 1-13 mm	3050572
Morse taper MT 2/B16	3050659
Twist drill bit HSS / MT 2, 9 parts	3051002
Assortment of clamping tools size 10, 58-parts	3352016
Taper drill punch MSP1	3050636
Collet chuck set MT 2/ ER 25	3352052

Accessories B 28H	Article no.
Quick release chuck direct MT 3	3050573
Reduction sleeve MT 3 - MT 2	3050663
Morse taper MT 3/B16	3050660
Twist drill bit HSS / MT 3, 9 parts	3051003
Assortment of clamping tools size 12, 58-parts	3352017
Thread tapping chuck M3 - M12	3050705
Thread tapping chuck M8 - M20	3050706
Collet chuck set MT 3/ ER 32	3352093

Accessories B 34H	Article no.
Quick release chuck direct MT 4	3050574
Morse taper MT 4/B16	3050661
Reduction sleeve MT 4 - MT 3	3050664
Assortment of clamping tools size 12, 58-parts	3352017
Thread tapping chuck M3 - M12	3050709
Thread tapping chuck M8 - M20	3050710
Collet chuck set MT 4/ ER 32	3352094

Bench-mounted drilling machine with continuously adjustable speed control.

Machine highlight - menu-controlled operation of the drilling/thread tapping operation modes

Facts that impress in terms of quality, performance and price

- ▶ Best possible force transmission thanks to aluminium pulleys
- ▶ Emergency stop button
- ▶ Drill spindle with precision ball bearings
- ▶ Guaranteed concentricity less than 0.03 mm measured at the drilling spindle sleeve
- ▶ Dirt- and water-resistant, easy-to-clean membrane keyboard with high-contrast OLED display
- ▶ Anti-glare LED lighting on the left and right, integrated into the drilling head. No annoying shadows
- ▶ Thread tapping mode
- ▶ Language selection in display field, choice of DE-EN-FR-RU
- ▶ Digital reference point
- ▶ Digital parts counter
- ▶ Audible signal on reaching drilling depth
- ▶ Reduced speed in thread tapping mode
- ▶ Height adjustability chuck guard with microswitch for maximum protection
- ▶ Precision drilling table with parallel T-slots, precision surface finish
- ▶ Swivelling drilling table
- ▶ Solid base plate with parallel T-slots

OLED display

- > Spindle speed
- > Depth display (target/actual)
- > Counter
- > Selected tool and tool size



During drill and thread tapping, the machine automatically sets the optimum speed for the tool, after the user enters the drill diameter and material.

**Patent applied for
DE 10 2015 006 876 A1**





Technical specifications, accessories and dimensions

Model	DX 17V
Article no.	3020170
Electrical connection	
Electrical connection	230 V / 1 Ph ~50 Hz
Motor output	1.0 kW
Drilling performance	
Drilling performance in steel (S235JR)	Ø 16 mm
Continuous drilling performance in steel (S235JR)	Ø 13 mm
Thread tapping steel (S235JR)	8M
Spindle	
Spindle sleeve stroke	60 mm
Spindle seat	B 16
Throat	235 mm
Speeds	
Spindle speeds	50 - 4 000 rpm
Number of speeds	Electronic speed control
Drilling table	
Drilling table workspace L x W	290 x 290 mm
T-slot size / spacing / count	10 mm / 100 mm / 2
Rotating drilling table	360°
Clearance chuck - drilling table	98 - 315 mm
Machine base	
Machine base work area L x W	290 x 280 mm
T-slot size / spacing / count	14 mm / 100 mm / 2
Distance chuck - machine base	max. 385 mm
Dimensions	
Column diameter	Ø 60 mm
Length x width x height	425 x 475 x 980 mm
Weight	73 kg

Accessories	Article no.
Assortment of clamping tools size 8	3352015
Assortment of clamping tools size 12	3352017
T-slot nut 10 mm / M 8	3353020
T-slot nut 14 mm / M12	3353025
Twist drill bits HSS-CO 5%, 25 parts	3201010
NEW Twist drill bits HSS-CO 5%, 51 parts	3201020
NEW Twist drill bits HSS-CO 5%, 41 parts	3201021
Universal coolant unit 230 V	3352002
Coolant mist lubricator MMC 1 with magnetic holder	3356663
Coolant hose KMS 2	3356660
Machine chassis	3353000
Information „Machine bases“ on page 131	
› More „Accessories for drills“ from page 60	

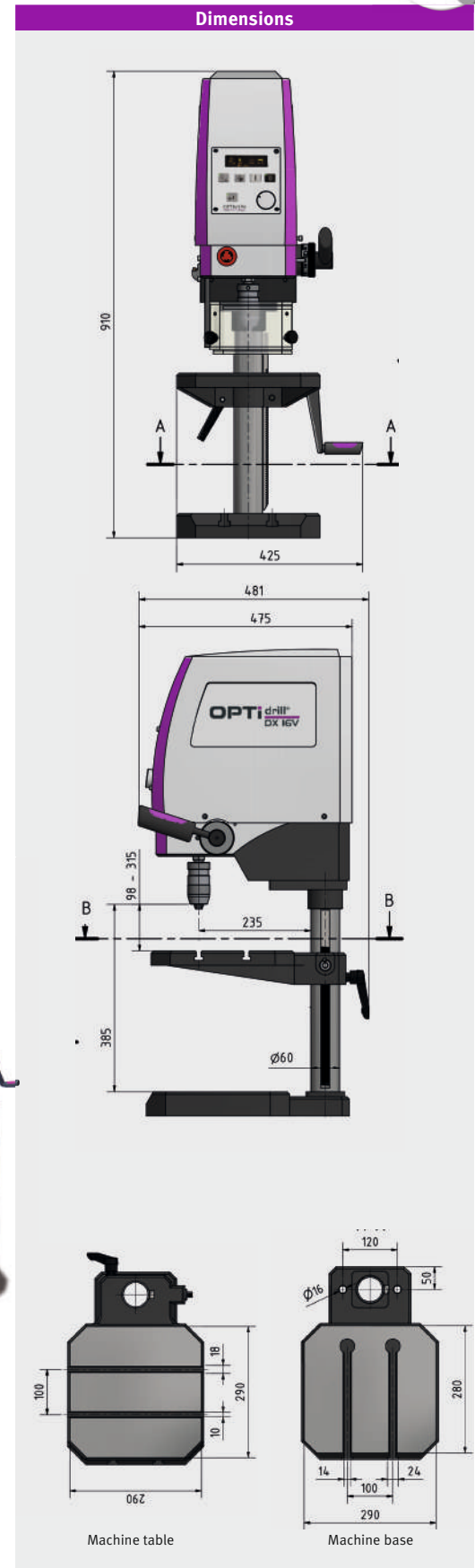

Machine vises	Article no.
BMS 85	3000008
BMS 100	3000010
BMS 120	3000012
BSI 100	3000210
BSI-Q 100	3000230
› Information on the vises on page 67	

Scope of supply

› Quick clamping drill chuck 1 - 13 mm

Important information on „Operation of machines with frequency converters“ on page 249
The drill (frequency converter) complies with the DIN EN 55011 standard: class C2

Table drilling machine with continuously adjustable speed control

Facts that impress in terms of quality, performance and price

- ▶ Best possible force transmission thanks to aluminium pulleys
- ▶ Digital speed display integrated in housing, speed control via potentiometer
- ▶ Emergency stop button
- ▶ Drill spindle with precision ball bearings
- ▶ Premium OPTIMUM quick clamping chuck as standard
- ▶ Guaranteed concentricity less than 0.03 mm measured at the drilling spindle sleeve
- ▶ Height adjustability chuck guard with microswitch
- ▶ Membrane keyboard, dirt/water-resistant, easy to clean
- ▶ Precision drilling table with parallel T-slots

- ▶ Thick walled cast column for high force absorption and stability
- ▶ Solid baseplate with, pronounced ribbing on rear
- ▶ EMC filter class C2

DX 13V

- ▶ Drill head height adjustable

DX 15V

- ▶ Drilling table height-adjustable via rack
- ▶ MT Adapter



Fig.: DX 13V



Fig.: DX 15V



Technical specifications, accessories and dimensions

Model	DX 13V	DX 15V
Article no.	3020150	3020155
Technical specifications		
Electrical connection	230 V / 1 Ph ~50 Hz	
Motor output	0.85 kW	
Drilling performance		
Drilling performance in steel (S235JR)	Ø 13 mm	Ø 15 mm
Continuous drilling performance in steel (S235JR)	Ø 11 mm	Ø 12 mm
Spindle		
Spindle sleeve stroke	60 mm	
Spindle seat	B 16	MT 2
Throat	235 mm	
Speeds		
Spindle speeds	100 - 3 000 rpm	
Number of speeds	Electronically controlled	
Drilling table		
Drilling table workspace L x W	-	290 x 290 mm
T-slot size / spacing / count	-	10 mm / 100 mm / 2
Rotating drilling table	-	360°
Clearance chuck - drilling table	-	98 - 375 mm
Machine base		
Machine base work area L x W	280 x 290 mm	290 x 280 mm
T-slot size / spacing / count	14 mm / 100 mm / 2	
Distance chuck - machine base	92 - 297 mm	290 - 355 mm
Dimensions		
Column diameter	Ø 60 mm	
Length x width x height	325 x 517 x 895 mm	425 x 475 x 980 mm
Weight	51 kg	66 kg

Accessories	Article no.
Twist drill bits HSS-CO 5%, 25 parts	3201010
NEW Twist drill bits HSS-CO 5%, 51 parts	3201020
NEW Twist drill bits HSS-CO 5%, 41 parts	3201021
T-slot nut (individual) M12 / 14 mm	3353025
Assortment of clamping tools size 12, 58-parts	3352017
Blank holder 14 mm/M12	3352031
Universal coolant unit	3352002
Coolant mist lubricator MMC 1 with magnetic holder	3356663
Coolant hose KMS 2	3356660
Machine chassis	3353000
Information „Machine bases“ on page 131	

Accessories DX 15V	Article no.
Twist drill HSS MT 2	3051002
Quick release chuck direct MT 2 / 1 - 16 mm	3050571
Quick release chuck direct MT 2 / 1 - 13 mm	3050572
Morse taper MT 2/B16	3050659
T-slot nut (individual) M 8 / 10 mm	3353022
Assortment of clamping tools size 8, 58-parts	3352015
Thread tapping chuck 6 inserts, sizes M3 - M12	3050702
Thermdrill MT 2	3060005

Machine vises	Article no.
BMS 85	3000008
BMS 100	3000010
BMS 120	3000012
BSI 100	3000210
BSI-Q 100	3000230

> Information on the vises on page 67

Important information on „Operation of machines with frequency converters“ on page 249
The drilling machines (frequency inverters) comply with standard DIN EN 55011: Class C2

Dimensions DX 13V

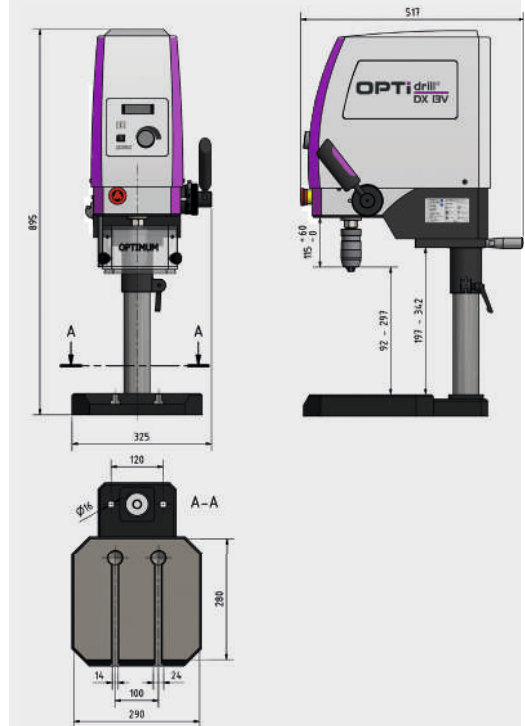

Dimensions DX 15V

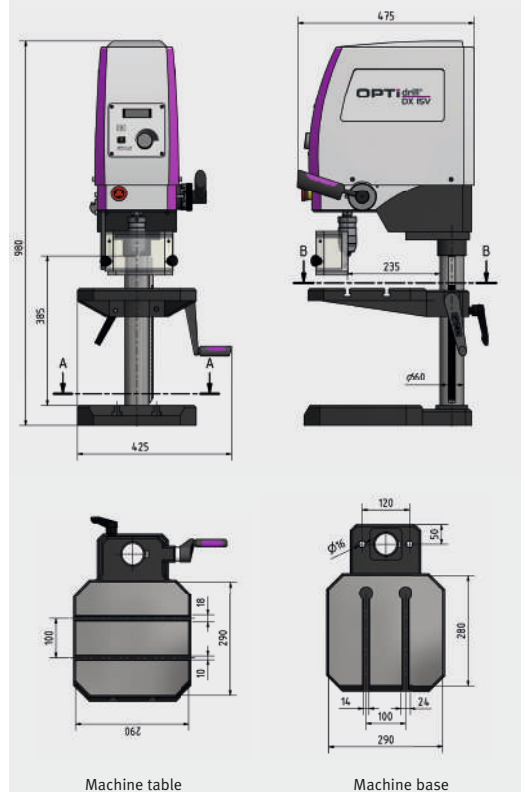

Scope of supply

> Quick-action drill chuck 1 - 13 mm

Preface

Drilling

Milling

Turning

Saws

Grinding

Polishing

Lamps

Measuring

Bench/Upright drills with V-belt drive

Facts that impress in terms of quality, performance and price

- ▶ Industrial motor
- ▶ User-friendly safety switch with IP 54 degree of protection
- ▶ Digital drilling depth display and spindle speed integrated in housing
- ▶ Separate emergency stop button
- ▶ Precision spindle bore
- ▶ Safety electrical system in 24 V DC
- ▶ Guaranteed concentricity less than 0.02 mm measured in the drilling spindle sleeve
- ▶ Drill spindle with precision ball bearings
- ▶ Premium quick clamping chuck
- ▶ Drilling depth stop
- ▶ Precise workmanship; stable drilling table with diagonal T-slots and all-around cooling water channel
- ▶ V-belt cover with safety switch
- ▶ Single-piece, pressure cast aluminium spindle sleeve lever with Softgrip handles

- ▶ Generously dimensioned, height adjustable protective screen with safety switch
- ▶ Heavy duty design of entire machine

As of D 23 Pro

- ▶ GATES quality belts

As of D 23 Pro / 400 V

- ▶ Right-handed/left-handed rotation

D 33Pro

- ▶ Solid, generously dimensioned baseplate with T-slots, pronounced ribbing on rear



Belt drive

- › Smooth action thanks to polished multi-tooth carrier
- › Best possible force transmission thanks to aluminium pulleys in combination with GATES quality toothed belts (as of D 23Pro)



Fig.: D 17Pro



Fig.: D 23Pro



Fig.: D 26Pro



Fig.: D 33Pro



Technical specifications, accessories and dimensions

Model	D 17Pro	D 23Pro	D 26Pro	D 33Pro
Article no. (230 V)	3003010	3003015	-	-
Article no. (400 V)	-	3003020	3003030	3003040
Technical specifications				
Electrical connection	230 V / 1 Ph ~50 Hz	230 V/1 Ph w.o. 400 V/3 Ph	400 V / 3 Ph ~ 50 Hz	400 V / 3 Ph ~ 50 Hz
Motor output	500 W	750 W	750 W	1.1 kW
Drilling performance				
Drilling performance in steel (S235JR)	Ø 16 mm	Ø 25 mm	Ø 25 mm	Ø 30 mm
Continuous drilling performance in steel (S235JR)	Ø 12 mm	Ø 20 mm	Ø 20 mm	Ø 25 mm
Spindle				
Spindle sleeve stroke	65 mm	80 mm	85 mm	120 mm
Spindle seat	MT 2	MT 2	MT 3	MT 4
Throat	152 mm	180 mm	210 mm	254 mm
Speeds				
Spindle speeds	680 - 2 700 rpm	200 - 2 440 rpm	200 - 2 440 rpm	120 - 1 810 rpm
Number of speeds	5 speeds	12 speeds	12 speeds	9 speeds
Drilling table				
Drilling table workspace L x W	235 x 220 mm	280 x 245 mm	330 x 290 mm	475 x 425 mm
T-slot size	12 mm, diagonal	12 mm, diagonal	14 mm, diagonal	14 mm, diagonal
Drill table rotation/lateral tilt	360° / ± 90°	360° / ± 90°	360° / ± 90°	360° / ± 90°
Clearance spindle - drilling table	max. 325 mm	max. 425 mm	max. 720 mm	max. 695 mm
Machine base				
Machine base work area L x W	220 x 230 mm	240 x 250 mm	385 x 260 mm	410 x 325 mm
T-slot size / spacing / count	16 mm / 148 mm / 2	16 mm / 170 mm / 2	16 mm / 170 mm / 2	16 mm / 250 mm / 2
Distance spindle - machine base	max. 530 mm	max. 618 mm	max. 1 230 mm	max. 1 180 mm
Dimensions				
Column diameter	Ø 60 mm	Ø 73 mm	Ø 80 mm	Ø 92 mm
Length x width x height	565 x 275 x 840 mm	615 x 330 x 1 015 mm	670 x 355 x 1 640 mm	755 x 440 x 1 705 mm
Weight	41.5 kg	58 kg / 63.5 kg	85 kg	137 kg

Scope of supply

- > Quick-action drill chuck 1 - 16 mm
- > Morse cone
- > T-slot nuts

Accessories	Article no.
Hold-down device 14 mm/M12	3352031
Twist drill bits HSS-CO 5%, 25 parts	3201010
NEW Twist drill bits HSS-CO 5%, 51 parts	3201020
NEW Twist drill bits HSS-CO 5%, 41 parts	3201021
Quick clamping drill chuck 1 - 8 mm; B16	3050608
Quick clamping drill chuck 1 - 10 mm; B16	3050610
Quick clamping drill chuck 1 - 13 mm; B16	3050623
Quick clamping drill chuck 1 - 16 mm; B16	3050626
Universal coolant unit 230 V	3352002
Coolant mist lubricator MMC 1 with magn. holder	3356663
Coolant hose KMS 2	3356660
> More „Accessories for drills“ from page 60	

Machine vices	Article no.
BMS 85	3000008
BMS 100	3000010
BMS 120	3000012
BSI 100	3000210
BSI-Q 100	3000230
> Information on the vices on page 67	

Accessories D 17Pro / D 23Pro	Article no.
Direct quick release chuck 1 - 16 mm	3050571
Direct quick release chuck 1 - 13 mm	3050572
Collet chuck set MT 2/ER 25	3352052
Morse taper MT 2/B16	3050659
Twist drill bit HSS / MT 2, 9 parts	3051002
Thread tapping chuck MT 2	3050702
Assortment of clamping tools size 10	3352016

Accessories D 26Pro	Article no.
Direct quick release chuck 1 - 16 mm	3050573
Collet chuck set MT 3/ER 32	3352093
Reduction sleeve MT 3 - MT 2	3050663
Morse taper MT 3/B16	3050660
Twist drill bit HSS / MT 3, 9 parts	3051003
Taper drill punch MSP1	3050636
Assortment of clamping tools size 12	3352017
Assortment of clamping tools size 14	3352018

Accessories B 33Pro	Article no.
Direct quick release chuck 1 - 16 mm	3050574
Collet chuck set MT 4/ER 32	3352094
Reduction sleeve MT 4 - MT 3	3050664
Reduction sleeve MT 4 - MT 3	3350314
Morse taper MT 4/B16	3050661
Taper drill punch MSP2	3050637
Assortment of clamping tools size 12	3352017
Assortment of clamping tools size 14	3352018

Preface

Drilling

Milling

Turning

Saws

Grinding

Polishing

Lamps

Measuring

Lightweight radial drilling machine with long outreach for wood, plastics, aluminium

Facts that impress in terms of quality, performance and price

- ▶ Best possible force transmission thanks to aluminium pulleys in combination with GATES quality toothed belts
- ▶ Guaranteed concentricity of drill spindle better than 0.03 mm measured in the drilling spindle sleeve
- ▶ Height-adjustable chuck protection with micro switch for best possible user protection
- ▶ Drill spindle with precision ball bearings
- ▶ V-belt cover with safety switch
- ▶ Precision drilling table with fastening holes for extended drilling table support
- ▶ Steel column for extremely smooth action and stability
- ▶ Solid and generously dimensioned baseplate with grooves for T slot nuts, rear with pronounced ribbing
- ▶ User-friendly safety switch with IP 54 degree of protection
- ▶ Separate emergency stop button
- ▶ Drilling depth stop
- ▶ OPTIMUM key type drill chuck in standard scope of delivery
- ▶ Optimal price-performance ratio
- ▶ Lasting value



› Variable outreach by displacing the drilling head



› The drilling head pivots through $\pm 45^\circ$



Drilling table

- › Precise workmanship
- › Diagonal T-slots
- › Circumferential coolant channel
- › The drilling table pivots through $\pm 45^\circ$



Fig.: RB 6T

Fig.: RB 8S

Technical specifications, accessories and dimensions

Model	RB 6T	RB 8S
Article no.	3009161	3009181
Technical specifications		
Electrical connection	230 V / 1 Ph ~50 Hz	
Motor output	750 W	
Drilling performance		
Drilling performance in steel (S235JR)	Ø 16 mm	
Continuous drilling performance in steel (S235JR)	Ø 12 mm	
Spindle		
Spindle sleeve stroke	80 mm	
Spindle seat	MT 2	
Throat	115 - 430 mm	
Speeds		
Spindle speeds	390 - 3 000 rpm	
Number of speeds	5 speeds	
Drilling table		
Drilling table workspace L x W	225 x 230 mm	262 x 262 mm
Groove size	14 mm, diagonal	
Pivoting drilling table	± 45°	
Clearance spindle - drilling table	max. 380 mm	max. 740 mm
Machine base		
Machine base work area L x W	430 x 260 mm	600 x 350 mm
Groove size / spacing / count	14 mm / 130 mm / 2	14 mm / 220 mm / 2
Clearance spindle - machine base	max. 550 mm	max. 1 250 mm
Dimensions		
Column diameter	Ø 60 mm	Ø 70 mm
Length x width x height	820 x 335 x 930 mm	820 x 395 x 1 640 mm
Weight	47 kg	60 kg

Scope of supply

- › Key type drill chuck 1 - 16 mm B 16
- › Morse taper MT 2/B16

Accessories

Accessories	Article no.
Quick release chuck direct MT 2 / 1 - 16 mm	3050571
Quick release chuck direct MT 2 / 1 - 13 mm	3050572
Morse taper MT 2/B16	3050659
Twist drill bit HSS / MT 2, 9 parts	3051002
Assortment of clamping tools size 12, 58-parts	3352017
Taper drill punch MSP1	3050636
Universal coolant unit 230 V	3352002
Coolant mist lubricator MMC 1 with magnetic holder	3356663
Coolant hose KMS 2	3356660
Twist drill bits HSS-CO 5%, 25 parts	3201010
Twist drill bits HSS-CO 5%, 51 parts	3201020
Twist drill bits HSS-CO 5%, 41 parts	3201021

› More „Accessories for drills“ from page 60

Machine vices

Machine vices	Article no.
MSO 125	3000125
BMS 120	3000012
BSI 100	3000210
BSI-Q 100	3000230

› Information on the vises on page 67



Dimensions RB 6T

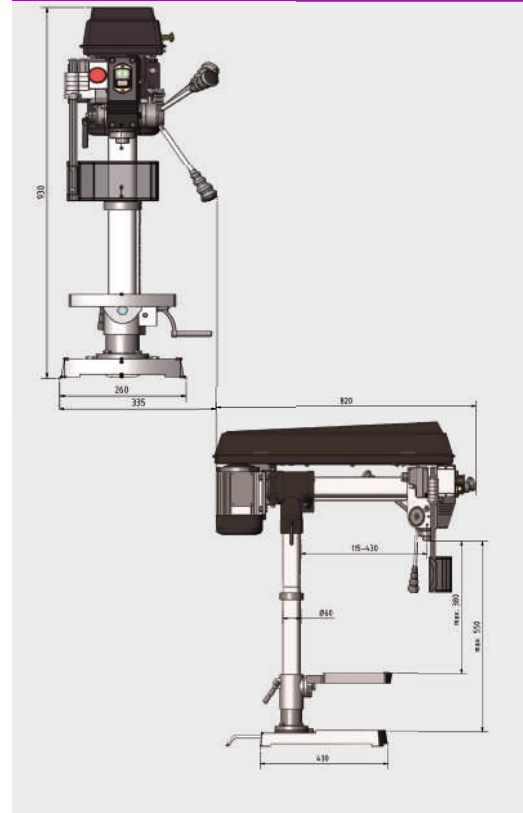

Dimensions RB 8S

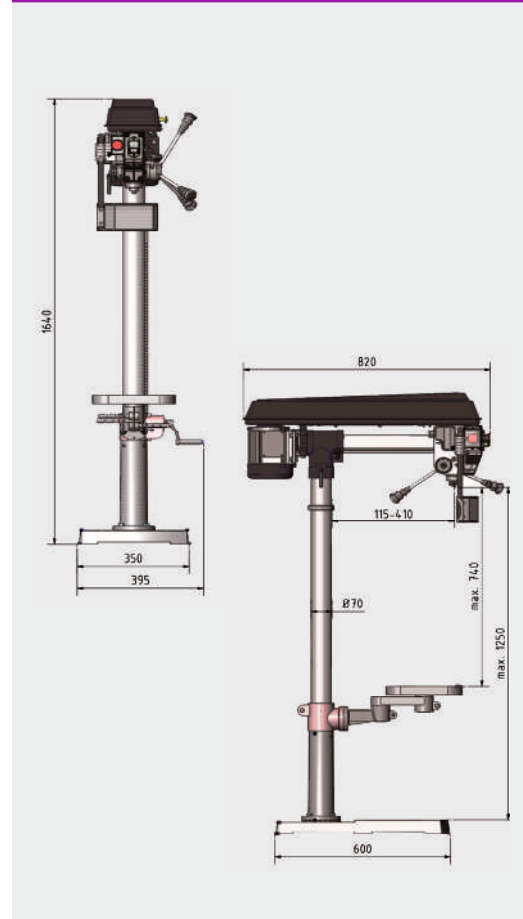

Preface

Drilling

Milling

Turning

Saws

Grinding

Polishing

Lamps

Measuring

Inexpensive bench/Upright drills with V-belt drive

Facts that impress in terms of quality, performance and price

- ▶ Precision drilling table, pivots through $\pm 45^\circ$
- ▶ Solid, generously dimensioned baseplate with grooves, rear with pronounced ribbing
- ▶ Quality proven in millions of applications

As of B 14

- ▶ T-slot nut for fastening vice

As of B 20

- ▶ Precise workmanship; stable drilling table with diagonal T-slots and all-around cooling water channel

As of B 20 / 400 V

- ▶ Right-handed/left-handed rotation



Fig.: B 13



Fig.: B 14



Fig.: B 16



Fig.: B 20

Model	B 13	B 14	B 16	B 20	
Article no.	3008131	3008141	3008161	3008201	3008203
Technical specifications					
Electrical connection	230 V / 1 Ph ~50 Hz	230 V / 1 Ph ~50 Hz	230 V / 1 Ph ~50 Hz	230 V / 1 Ph	400 V / 3 Ph
Motor output	300 W	350 W	450 W	0.55 kW	
Drilling performance					
Drilling performance in steel (S235JR)	Ø 13 mm	Ø 14 mm	Ø 16 mm	Ø 20 mm	
Continuous drilling performance in steel (S235JR)	Ø 12 mm	Ø 12 mm	Ø 15 mm	Ø 18 mm	
Spindle					
Spindle sleeve stroke	50 mm	50 mm	65 mm	80 mm	
Throat	104 mm	104 mm	125 mm	170 mm	
Spindle seat	fixed/B16	fixed/B16	MT 2	MT 2	
Speeds					
Spindle speeds	520 - 2 620 rpm	520 - 2 620 rpm	660 - 2 500 rpm	210 - 2 220 rpm	
Number of speeds	5 speeds	5 speeds	5 speeds	12 speeds	
Drilling table					
Drilling table workspace L x W	160 x 160 mm	160 x 160 mm	200 x 200 mm	275 x 275 mm	
T-slot width	14 mm, diagonal	14 mm, diagonal	14 mm, diagonal	14 mm, diagonal	
Drill table rotation/lateral tilt	360° / $\pm 45^\circ$	360° / $\pm 45^\circ$	360° / $\pm 45^\circ$	360° / $\pm 45^\circ$	
Clearance spindle - drilling table	max. 240 mm	max. 330 mm	max. 390 mm	max. 465 mm	
Machine base					
Machine base work area L x W	135 x 175 mm	140 x 180 mm	160 x 170 mm	205 x 200 mm	
Distance spindle - machine base	max. 325 mm	max. 440 mm	max. 525 mm	max. 645 mm	
Dimensions					
Column diameter	46 mm	46 mm	60 mm	70 mm	
Length x width x height	420 x 220 x 580 mm	420 x 230 x 700 mm	510 x 270 x 820 mm	600 x 350 x 990 mm	
Weight	18 kg	20 kg	34 kg	51 kg	



Fig.: B 25

Fig.: B 32

Model	B 25	B 32
Article no.	3008253	3008323
Technical specifications		
Electrical connection	400 V / 3 Ph ~50 Hz	400 V / 3 Ph ~50 Hz
Motor output	0.55 kW	1.1 kW
Drilling performance		
Drilling performance in steel (S235JR)	Ø 20 mm	Ø 32 mm
Continuous drilling performance steel (S235JR)	Ø 18 mm	Ø 28 mm
Spindle		
Spindle sleeve stroke	80 mm	125 mm
Throat	170 mm	225 mm
Spindle seat	MT 3	MT 4
Speeds		
Spindle speeds	210 - 2 220 rpm	140 - 2 020 rpm
Number of speeds	12 speeds	9 speeds
Drilling table		
Drilling table workspace L x W	275 x 275 mm	360 x 360 mm
T-slot size	14 mm, diagonal	14 mm, diagonal
Drill table rotation/lateral tilt	360° / ± 45°	360° / ± 45°
Clearance spindle - drilling table	max. 760 mm	max. 600 mm
Machine base		
Machine base work area L x W	235 x 220 mm	260 x 270 mm
Distance spindle - machine base	max. 1 210 mm	max. 1 170 mm
Dimensions		
Column diameter	Ø 70 mm	Ø 92 mm
Length x width x height	690 x 390 x 1 570 mm	790 x 400 x 1 730 mm
Weight	57 kg	137 kg



- > Ground multi-tooth carrier
- > Best possible force transmission thanks to aluminium pulleys in combination with GATES quality toothed belts
- > V-belt cover with safety switch



- > Guaranteed concentricity better than 0.03 mm measured in the drilling spindle sleeve
- > Drilling spindle with precision ball bearings
- > OPTIMUM quick clamping drill chuck included in standard scope of delivery (B13 with key type drill chuck)



- > User-friendly switch as per IP 54
- > Separate emergency stop button

Scope of supply

B 13

- > Key type drill chuck 1.5 - 13 mm

B 14

- > Quick-action drill chuck 1 - 13 mm
- > T-slot nuts

B 16 / B 20

- > Quick-action drill chuck 1 - 16 mm
- > Morse taper MT 2/B16
- > T-slot nuts

B 25

- > Quick-action drill chuck 1 - 16 mm
- > Morse taper MT 3/B16
- > T-slot nuts

B 32

- > Quick-action drill chuck 1 - 16 mm
- > Morse taper MT 4/B16
- > T-slot nuts

- > „Accessories for drills“ from page 60

Precision, solid radial drilling machines, premium quality

Ideal for versatile deployment in one-off and serial production

Facts that impress in terms of quality, performance and price

- ▶ Versatile range of applications, such as drilling, reaming, thread tapping
- ▶ Electrically braked motor
- ▶ Control elements with 24 V DC electronics
- ▶ Heavy, solid, premium quality casting
- ▶ Long reach thanks to horizontally adjustable machine head
- ▶ Clear-cut control panel layout
- ▶ Smooth action pivoting and travel axes
- ▶ Swivelling column with sophisticated workmanship and optimised clamping for maximum stability and minimum clamping offset
- ▶ Torsionally stiff boom design, capable of supporting heavy loads
- ▶ Height-adjustment of boom via powerful motorised drive and lifting spindle
- ▶ Drilling head gear box runs in oil sump
- ▶ Boom guideways tempered and precision ground
- ▶ Gear wheels made of chrome-nickel steel, tempered and precision ground for lower noise and smooth action
- ▶ Drilling head and column can be clamped or released separately
- ▶ Right-handed/left-handed rotation
- ▶ Solid, generously dimensioned precision drilling table
- ▶ Hardened and ground clamping table with parallel T-slots
- ▶ Machine lamp
- ▶ Overload protection
- ▶ Thick-walled cast column ensures very smooth action and stability
- ▶ LED lamp
- ▶ Coolant unit with coolant tank in machine base

RD 4 / RD 5

- ▶ All axes are clamped manually

RD 6

- ▶ Column is clamped hydraulically

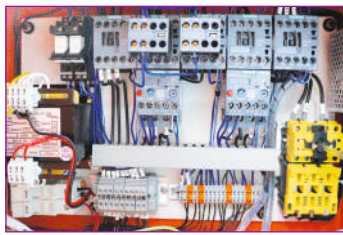

Clear-cut DC control cabinet



Pull-out shift rod

- › Standards-compliant as per DIN 12717



Fig. RD 5 with optional accessories

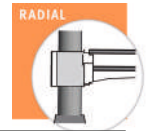

Technical data and accessories

Model	RD 4	RD 5	RD 6
Article no.	3049040	3049050	3049070
Technical specifications			
Electrical connection	400 V / 3 Ph ~50 Hz	400 V / 3 Ph ~50 Hz	400 V / 3 Ph ~50 Hz
Total rated value	3 kW	4 kW	6.5 kW
Spindle motor drive output	1.5 kW	2.25 kW	4 kW
Boom lift motor drive output	0.75 kW	0.75 kW	1.5 kW
Hydraulic clamping drive	-	-	0.75 kW
Coolant pump motor	90 W	90 W	90 W
Drilling performance			
Drilling performance in steel (S235JR)	Ø 32 mm	Ø 42 mm	Ø 50 mm
Continuous drilling performance in steel (S235JR)	Ø 28 mm	Ø 40 mm	Ø 45 mm
Thread tapping steel (S235JR)			
Spindle			
Spindle sleeve stroke	220 mm	230 mm	270 mm
Spindle seat	MT 4	MT 4	MT 5
Automatic spindle sleeve feed	3 speeds: 0.05-0.15 mm/rev	3 speeds: 0.05-0.15 mm/rev	3 speeds: 0.06-0.2 mm/rev
Boom			
Angle of rotation	± 180°	± 180°	± 180°
Drilling head travel (horizontal)	530 mm	820 mm	1 250 mm
Boom lift stroke (vertical)	580 mm	570 mm	680 mm
Speeds			
Spindle speeds	73 - 1 247 rpm	37 - 1 253 rpm	44 - 1 206 rpm
Number of speeds	6	12	12
Drilling table			
Large base L x W	1 260 x 700 mm	1 608 x 745 mm	2 550 x 970 mm
Base work area L x W x H	828 x 522 mm	1 147 x 589 mm	1 800 x 830 mm
T-slot size / spacing / count	19 mm / 171 mm / 3	19 mm / 171 mm / 3	14 mm / 180 mm / 4
Clearance spindle to base	260 - 1 060 mm	470 - 1 270 mm	465 - 1 420 mm
Distance spindle to column	220 - 750 mm	280 - 1 100 mm	350 - 1 600 mm
Clamping table			
Clamping table work area L x W	600 x 445 x 380 mm	635 x 520 x 415 mm	630 x 500 x 500 mm
T-Slot size / no / distance	19 mm / 100 mm / 3	19 mm / 121 mm / 3	22 mm / 150 mm / 3
Distance spindle to clamping table	0 - 675 mm	50 - 850 mm	0 - 910 mm
Dimensions			
Column diameter	210 mm	260 mm	320 mm
Length x width x height (max.)	1 260 x 700 x 2 180 mm	1 725 x 745 x 2 550 mm	2 670 x 1 120 x 2 760 mm
Weight	1 120 kg	1 800 kg	3 200 kg

Accessories	Article no.
Precision quick release chucks 1 - 8 mm; B16	3050608
Precision quick release chucks 1 - 10 mm; B16	3050610
Precision quick release chucks 1 - 13 mm; B16	3050623
Precision quick release chucks 1 - 16 mm; B16	3050626
› More „Accessories for drills“ from page 60	

Accessories RD 4 / RD 5	Article no.
Quick release chuck direct MT 4 / 1 - 16 mm	3050574
Reduction sleeve MT 4 - MT 3	3050664
Twist drill HSS / MT 3	3051003
Morse taper MT 4/B16	3050661
Blank holder 18 mm/M16	3352032
Assortment of clamping tools size 16, 58 parts	3352019

Accessories RD 6	Article no.
Morse taper MT 5/B16	3050675
Assortment of clamping tools size 12, 58 parts	3352017

Scope of supply
› Clamping table

Preface

Drilling

Milling

Turning

Saws

Grinding

Polishing

Lamps

Measuring

Precision radial drilling machine with standard chassis and clamping table. Suitable for machining bulky workpieces

Facts that impress in terms of quality, performance and price

- ▶ Versatile range of applications
- ▶ Powerful premium motor
- ▶ Electrically braked motor
- ▶ Long reach thanks to horizontally adjustable machine head
- ▶ Mechanical head, column and boom clamping
- ▶ Solid grey cast iron ensures stability, smooth action and precision
- ▶ Spindle with precision taper roller bearings
- ▶ Guaranteed concentricity better than 0.015 mm measured in the drilling spindle sleeve
- ▶ Large speed range from 155 - 2 250 rpm thanks to two-speed motor
- ▶ Solid, precision drilling table, generously dimensioned with precision surface finish and parallel T grooves
- ▶ Thick-walled steel column (Ø 115 mm) ensures smooth action and stability

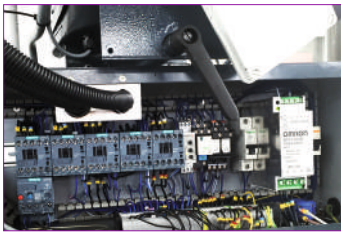

Complete DC control cabinet



Controls with 24 V DC electrical system



Pull-out shift rod

- › Standards-compliant as per DIN 12717



Figure shows optional chuck

Technical specifications, accessories and dimensions

Model	RD 3
Article no.	3049030
Technical specifications	
Electrical connection	400 V / 3 Ph ~ 50 Hz
Motor output	0.55 / 1.1 kW
Drilling performance	
Drilling performance in steel (S235JR)	Ø 28 mm
Continuous drilling performance in steel (S235JR)	Ø 24 mm
Thread tapping steel (S235JR)	M12
Spindle	
Spindle sleeve stroke	130 mm
Spindle seat	MT 3
Throat	160 - 530 mm
Speeds	
Spindle speeds	155 - 2 250 rpm
Number of speeds	2 x 5 speeds
Drilling table	
Drilling table workspace L x W	780 x 520 mm
Usable workpiece mounting surface	500 x 550 mm
T-slot size / spacing / count	16 mm / 100 mm / 3
Drilling table load bearing capacity	200 kg
Clearance spindle - drilling table	170 - 630 mm
Clamping table	
Length x width x height	280 x 230 x 200 mm
T-slot size / spacing / count	16 mm / 98 mm / 2
Distance spindle to clamping table	max. 430 mm
Dimensions	
Column diameter	Ø 115 mm
Length x width x height	870 x 645 x 1 550 mm (chassis 2 150 mm)
Weight	288 kg

Accessories	Article no.
Quick release chuck direct MT 3/ 1 - 16 mm	3050573
Precision quick release chucks 1 - 8 mm; B16	3050608
Precision quick release chucks 1 - 10 mm; B16	3050610
Precision quick release chucks 1 - 13 mm; B16	3050623
Precision quick release chucks 1 - 16 mm; B16	3050626
Reduction sleeve MT 3 - MT 2	3050663
Morse taper MT 3/B16	3050660
Extension sleeve MT 3 - MT 4	3050668
Twist drill bit HSS / MT 3, 9 parts	3051003
Twist drill bits HSS-CO 5%, 25 parts	3201010
NEW Twist drill bits HSS-CO 5%, 51 parts	3201020
NEW Twist drill bits HSS-CO 5%, 41 parts	3201021
Assortment of clamping tools size 14, 58 parts	3352018
Universal coolant unit	3352002
Thread tapping chuck MT 3 with 6 inserts	3050705
Collet chuck set MT 3/ ER 32 - M12	3352093
› More „Accessories for drills“ from page 60	

Machine vices	Article no.
BSI 140	3000214
BSI 200	3000220
BSI-Q 140	3000234
BSI-Q 200	3000240
› Information on the vices on page 67	

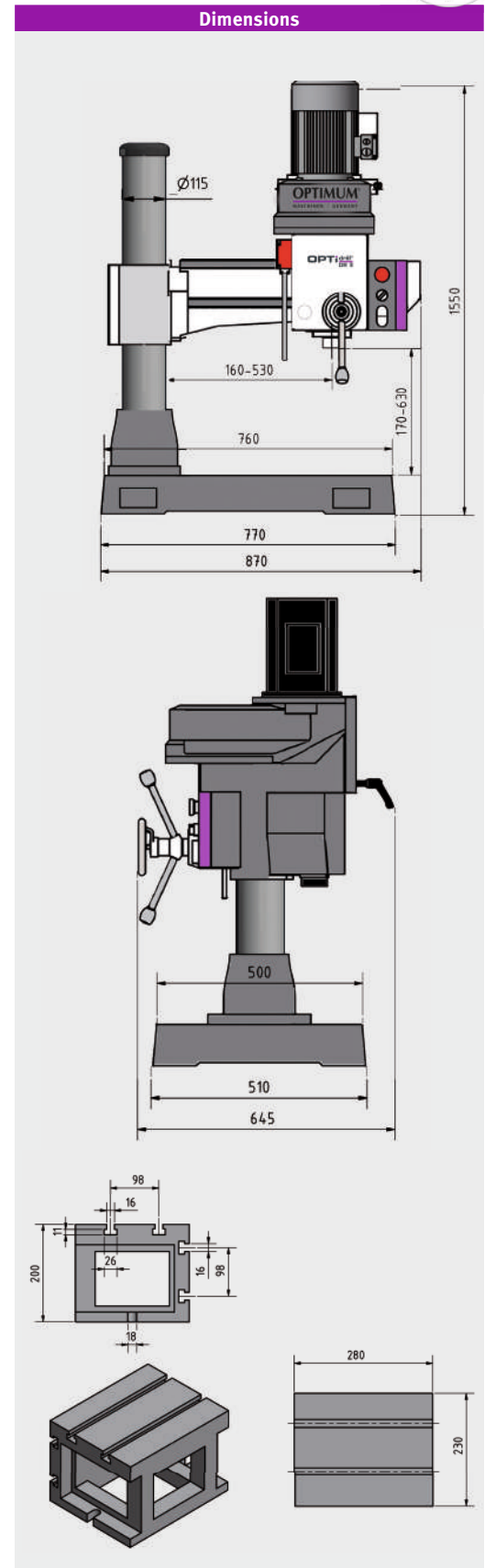

Scope of supply

- › Machine chassis
- › Clamping table

Preface

Drilling

Milling

Turning

Saws

Grinding

Polishing

Lamps

Measuring

Accessories drilling			Belt-driven drills																Drills with gear units								Radial drills												
			B13	B14	B16	B20	B25	B32	D 17Pro	D 23Pro	D 26Pro	D 33Pro	B 16 H	B 24H / B 24HV	B 28H / B 28HV	B 34H / B 34HV	DH 18V	DX 13V	DX 15V	DX 17V	DH 248V	DH 288V	DH 408V	DH 26GT	DH 28GS / DH 28GSV	DH 32GS / GSV	DH 40CT	DH 40G / DH 40GP	B 40GSP / GSM	DH 35G / DH 35V	DH 45G / DH 45V	B 50GSM	DH 55G	RB 6T	RB 8S	RD 3	RD 4 / RD 5	RD 6	
			B16	B16	MK2	MK2	MT3	MT4	MT3	MT4	MK2	MK2	MT3	MT4	MT3	MT4	B16	MT2	MT2	B16	MK2	MT3	MT4	MT3	MT4	MT4	MT4	MT4	MT4	MT4	MT4	MT4	MT4	MT4	MT2	MT2	MT3	MT4	MT5
Twist drill bit set	25-part	3201010	●	●	●	●	●	●	●	●	●	●	●	●	●	●	●	●	●	●	●	●	●	●	●	●	●	●	●	●	●	●	●	●	●	●	●	●	●
	51-part	3201020	●	●	●	●	●	●	●	●	●	●	●	●	●	●	●	●	●	●	●	●	●	●	●	●	●	●	●	●	●	●	●	●	●	●	●	●	●
	41-part	3201021	●	●	●	●	●	●	●	●	●	●	●	●	●	●	●	●	●	●	●	●	●	●	●	●	●	●	●	●	●	●	●	●	●	●	●	●	●
Conical counterbore set		3201050	●	●	●	●	●	●	●	●	●	●	●	●	●	●	●	●	●	●	●	●	●	●	●	●	●	●	●	●	●	●	●	●	●	●	●	●	●
Spot facer set		3201051			●	●	●		●	●		●	●	●	●	●	●	●	●	●	●	●	●	●	●	●	●	●	●	●	●	●	●	●	●	●	●	●	●
Step drill bit set		3201055							●	●																													
Step drill bit set		3201056							●	●																													
Thread repair assortment		3202010	●	●	●	●	●	●	●	●	●	●	●	●	●	●	●	●	●	●	●	●	●	●	●	●	●	●	●	●	●	●	●	●	●	●	●	●	●
Reducing sleeve	MT 3-MT 2	3050663				●			●					●									●	●														●	
	MT 4-MT 3	3050664					●			●					●									●		●			●	●	●	●							●
	MT 4-MT 2	3050665					●			●						●									●		●			●	●	●	●						●
Reducing sleeve	MT 3 - MT 2	3350313				●			●					●										●	●													●	
	MT 4 - MT 3	3350314					●			●						●									●		●	●	●	●	●								●
Morse cone B16	MT 2	3050659			●	●			●	●				●	●		●	●	●	●	●	●														●	●		
	MT 3	3050660				●			●						●									●	●													●	
	MT 4	3050661					●			●						●								●		●		●	●	●	●	●							●
Morse cone	MT 5	3050675																																				●	
Extension sleeve	MT 2 - MT 3	3050667													●					●																			
	MT 3 - MT 4	3050668														●									●													●	
Taper drill punch	MSP 1	3050636			●	●	●	●	●	●				●				●																		●	●	●	
	MSP 2	3050637											●				●								●		●											●	
Hold-down device	14 mm	3352031	●	●	●	●	●	●		●	●			●	●	●	●	●	●	●	●	●	●	●	●	●	●	●	●	●	●	●	●	●	●	●	●	●	
	18 mm	3352032																																				●	
Arbor for drill chuck	MT 4 / M16	3350304																									●	●											
Therm드릴	MT 2	3060005																							●	●												●	
Machine chassis		3353000	○	○	○	○			○	○							●	●	●	●																			

● Recommended

○ Recommended - restrictions apply

This equipment table covers all recommended equipment options. Depending on the individual case, use of accessories can be meaningful beyond this.

Preface

Drilling - Accessories

Milling

Turning

Saws

Grinding

Polishing

Lamps

Measuring

NEW

Accessories for drills

Clamping plate with 720 mm stop rail, ideal for any drilling table

Facts that impress in terms of quality, performance and price

- ▶ Quickly and easily fitted on the machine tables of drilling or milling machines
- ▶ Clamping elements and stop modules can be freely positioned and clamped without tools
- ▶ The table extension is attached to the side mounting rails and extends the clamping plate to the left, right or front

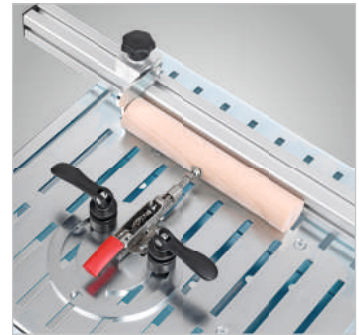

Adapter plate with clamp, horizontal

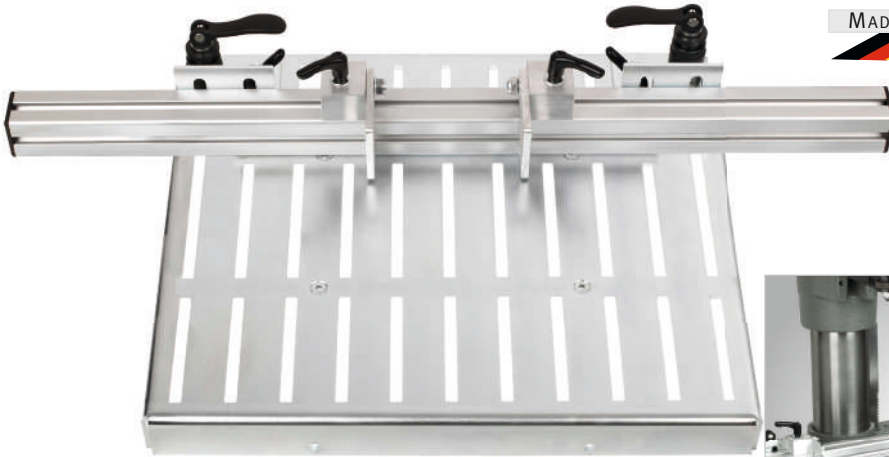

Machine vise clamped



Typical application: Stop rail

Accessories	Clamping plate
Article no.	5190015
Dimensions (L x W x H)	450 x 400 x 50 mm
Stop rail	720 mm
Overall weight	8.9 kg

Scope of supply
 › Clamping plate

Accessories

Clamping plate for drilling machines incl. assembly carrier 450 x 400 mm
 Art no. 5198110

Stop rail 720 mm incl. 2 clamping elements
 Art no. 5198121

Machine vise incl. 2 clamping elements
 Art no. 5198135

Stop and clamping element Ø30 mm
 Art no. 5198150

Position bracket incl. 1 clamping element
 Art no. 5198151

Adapter platen round with horizontal clamp length 180 mm
 Art no. 5198161

Adapter platen round with upright clamp length 180 mm
 Art no. 5198163

Connecting web
 Art no. 5850126

Table extension 1 100 x 172 mm
 Art no. 5850112

Mounting rail Length 330 mm left and right
 Art no. 5850103

Mounting rail Length 430 mm front
 Art no. 5850104

Collet chuck set

MT 2/ ER 25 - M10	3352052
› Collet chuck	
› 15 spring collets; sizes Ø 1.5 - Ø 16 mm/DIN ISO 15488	
› Hook wrench	
› Aluminium case	
MT 2/ ER 32 - M10	3352053
› Collet chuck	
› 18 spring collets; sizes Ø 2 - Ø 20 mm/DIN ISO 15488	
› Hook wrench	
› Aluminium case	
MT 3/ ER 32 - M12	3352093
› Collet chuck	
› 18 spring collets; sizes Ø 2 - Ø 20 mm/DIN ISO 15488	
› Hook wrench	
› Aluminium case	
MT 4/ ER 32 - M16	3352094
› Collet chuck	
› 18 spring collets; sizes Ø 2 - Ø 20 mm/DIN ISO 15488	
› Hook wrench	
› Aluminium case	



Thread tapping chuck M5 - M12 3352042

- › Quick reverse built-in, immediately effective on changing the feed direction
 - › Slip clutch 4-stage adjustable
 - › With collet B16
- Scope of delivery:**
- › 2 pcs. flexible spring collet
 - › 2 pcs. flat spanner
 - › *Allen key



Thread tapping chuck with 6 quick-change inserts

Note: The square size depends on the shank diameter of the manual thread tapping bit (ISO standard)

MT 2; sizes M3 - M12	3050702
MT 3; sizes M3 - M12	3050705
MT 4; sizes M3 - M12	3050709
M3, M4, M5, M6-8, M10, M12	
MT 3; sizes M8 - M20	3050706
MT 4; sizes M8 - M20	3050710
M8, M10, M12, M14, M16, M18-M20	



OPTIMUM Precision quick release chuck

Concentricity better than 0.06 mm

1 - 8 mm; B16	3050608
1 - 10 mm; B16	3050610
1 - 13 mm; B16	3050623
1 - 16 mm; B16	3050626



OPTIMUM Direct quick release chuck

MT 2 1 - 16 mm; up to 6 000 rpm	3050571
MT 2 1 - 13 mm; up to 8 000 rpm	3050572
MT 3 1 - 16 mm; up to 6 000 rpm	3050573
MT 4 1 - 16 mm; up to 6 000 rpm	3050574



Accessories for drills

Assortment of clamping tools size

- › Metric thread
- › 58-part: 24 pull studs, 6 T-slot nuts, 6 nuts, 4 extension nuts, 6 step blocks, 12 clamping blocks

Size 8 3352015

- › T-slot nuts 10 mm; locking thread M 8

Size 10 3352016

- › T-slot nuts 12 mm; locking thread M10

Size 12 3352017

- › T-slot nuts 14 mm; locking thread M12

Size 14 3352018

- › T-slot nuts 16 mm; locking thread M 14

Size 16 3352019

- › T-slot nuts 18 mm; locking thread M16



T-slot nut (individual)

10 mm; locking thread M 8	3353020
12 mm; locking thread M10	3353022
14 mm; locking thread M12	3353025
15.7 mm; locking thread M12	3353024
16 mm; locking thread M 14	3353026
18 mm; locking thread M16	3353028

Twist drill HSS with morse taper

- › 9-part; 14,5/16/18/20/22/24/26/28/30 mm
- › Long service life.
- › Good chip removal
- › Right handed

MT 2 3051002

MT 3 3051003

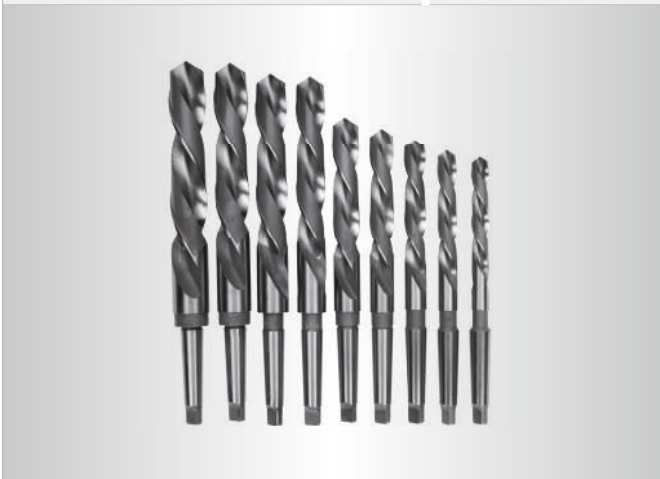

Twist drill set

- › As per DIN 338 HSS-CO 5%
- › Tetrahedral 135° split point allows for excellent self-centring
- › Improved tool service life thanks to alloyed components
- › High speed/feed properties
- › Strong core design optimises the structural strength of the bit and minimises the risk of bit breakage
- › Practical OPTIMUM plastic case

25-part 3201010

- › 1- 13 mm

51-part 3201020

- › 1- 6 mm (in 0.1 mm increments)

41-part 3201021

- › 6- 10 mm (in 0.1 mm increments)

NEW

NEW



Fig. Spiral drill bit set
41-part

NEW

Conical counterbore set

3201050

- › As per standard DIN 335C
- › 6-part: 6/8/10/11.5/15/19 mm
- › Premium conical counterbores Burrs are nicely chamfered and removed without causing scratches
- › Compatible with popular battery-powered screwdrivers and drills, including Upright drills
- › Practical OPTIMUM plastic case



NEW

Spot facer set

3201051

- > As per standard 373
- > 6-part: for M3 / M4 / M5 / M6 / M8 / M10 mm screws
- > HSS
- > Piloted counterbore size 6.5 x 3.2 mm / 8 x 4.3 mm / 10 x 5.3 mm / 11 x 6.4 mm / 15 x 8.54 mm / 18 x 10.5 mm
- > Fine grade for countersinking screws and nuts as per DIN 74
- > Practical OPTIMUM plastic case



Step drill bit set

3201055

- > 3-part: 3 - 14 mm / 8 - 20 mm / 16 - 30.5 mm
- > With sharp tip, no pre-drilling required
- > Conically rising blades and radially undercut circumference for peeling action
- > Drilling without burr and chatter marks
- > Uses: Steel sheet 0.1 - 2 mm, stainless steel (V2A) 0.1 - 1 mm, non-ferrous metals 0.1 - 5 mm, plastics - 10 mm
- > Practical OPTIMUM plastic case



Step drill bit set

3201056

- > 3-part: 4 - 12 mm / 12 - 20 mm / 20 - 30 mm
- > Drilling and deburring cylindrical holes in materials up to 4 or 6 mm thickness.
- > Shank with three clamping surfaces
- > Drill step increment 1 mm
- > Practical OPTIMUM plastic case



Thread repair assortment

3202010

- > 5 pcs. twist drill bit (5.2 mm/6.3 mm/8.3 mm/10.4 mm/12.4 mm)
- > 5 pcs. thread tap: (M5 / M6 / M8 / M10 / M12)
- > 5 pcs. inserter for threaded inserts
- > 5 pcs. tang breaker
- > 100 pcs. threaded inserts: 25 pcs. each M5x0.8 mm / M6x1.0 / M8x1.25 / M10x1.5
- > 10 pcs. threaded insert: M12x1.75 mm
- > For repairing defective threads
- > For reinforcing the thread on materials with a low shear strength
- > Practical OPTIMUM metal case



Drilling and thread tapping set

3202015

- > Through bore
- > 15-part
- > 7 pcs. thread tap: M3 / M4 / M5 / M6 / M8 / M10 / M12
- > 7 pcs. spiral bit DIN 338; Ø2.5 mm / Ø3.3 mm / Ø4.2 mm / Ø5.0 mm / Ø6.8 mm / Ø8.5 mm / Ø10.2 mm
- > Tap wrench DIN 1814 size 1½
- > Practical OPTIMUM plastic case



7 units
2.5 mm-
10.2 mm

7 units
M3-M12

Preface

Drilling - Accessories

Milling

Turning

Saws

Grinding

Polishing

Lamps

Measuring

Accessories for drills

Reducing sleeve

MT 3 - MT 2	3050663
MT 4 - MT 3	3050664
MT 4 - MT 2	3050665



Morse cone

MT 2 / B16	3050659
MT 3 / B16	3050660
MT 4 / B16	3050661
MT 5 - B16	3050675
MT 6 - B16	3050676



Extension sleeves

MT 2 - MT 3	3050667
MT 3 - MT 4	3050668



Taper drill punch

MSP 1 for MT 1 to MT 3	3050636
MSP 2 for MT 4 to MT 6	3050637



Arbor for drill chuck

External taper MT 3 / M12 / B16	3350303
External taper MT 4 / M16 / B16	3350304



Reducing sleeve

MT 3 - MT 2 / M12	3350313
MT 4 - MT 3 / M16	3350314



Hold-down unit set of 2

- > Clamping height adjustable
- > Brass plate below clamping arm protects material against damage

Table groove 14 mm/M12	3352031
------------------------	---------

- > L x W x H: 115 x 42 x 39 mm
- > Height adjustment: 0 - 89 mm

Table groove 18 mm/M16	3352032
------------------------	---------

- > L x W x H: 133 x 50 x 49 mm
- > Height adjustment: 0 - 101 mm



NEW

AQUACUT C1

3530030

- 10 litre cannister
- For mixing emulsions
- Drilling and cooling emulsion
- High-pressure resistant and containing mineral oil, for long tool life and clean surfaces
- Emulsifiable with water, microbe-resistant and kind to the skin



You will find more coolant accessories from page 242

Cross tables KT

Facts that impress in terms of quality, performance and price

- ▶ Coolant channel
- ▶ Dovetail guide adjustable
- ▶ Handwheels right, front and left - for model KT 120 only right and front
- ▶ Adjustable handwheel scaling with 0.05 mm scale

Technical specifications	KT 120	KT 179	KT 180	KT 210
A (Base width)	222 mm	274 mm	274 mm	280 mm
D (base length)	280 mm	340 mm	340 mm	362 mm
C (table length)	400 mm	500 mm	700 mm	730 mm
E (table width)	120 mm	180 mm	180 mm	210 mm
G (T-slot size)	10 mm	12 mm	12 mm	14 mm
Length x width x height	506 x 400 x 140 mm	748 x 483 x 155 mm	948 x 483 x 155 mm	1 060 x 538 x 185 mm
Weight	22 kg	40 kg	52 kg	84 kg
Travel				
X axis	220 mm	287 mm	480 mm	480 mm
Y axis	165 mm	167 mm	170 mm	210 mm
Max. load	40 kg	55 kg	55 kg	80 kg

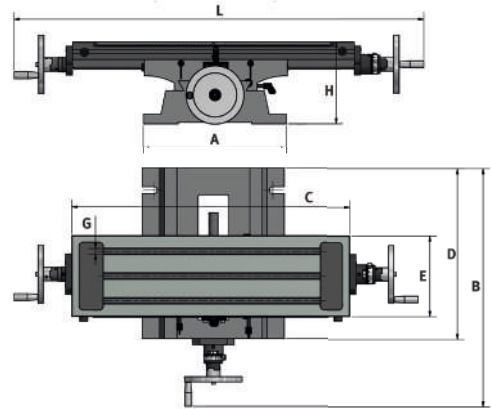

Cross tables KT	
KT 120	3356595
KT 179	3356596
KT 180	3356591
KT 210	3356600

Workplace mats – for dry and wet areas

Facts that impress in terms of quality, performance and price

- ▶ Fire-resistant
- ▶ Made of polyurethane on polyether basis
- ▶ Surface: nubbed
- ▶ Underside: nubbed for maximum standing comfort and slip resistance
- ▶ 5-year warranty

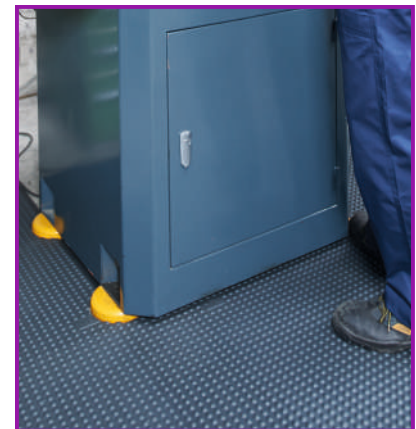
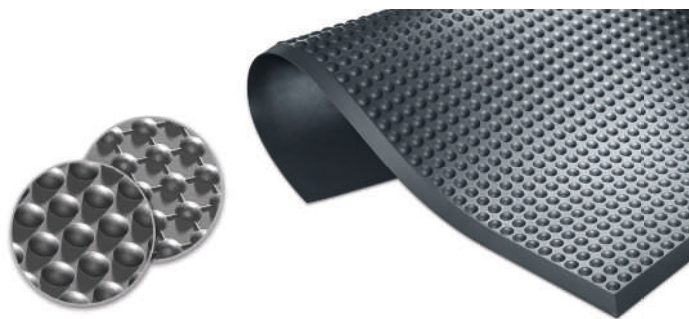

Technical specifications	Work mat 1 840 x 640 mm	Work mat 1 840 x 940 mm	Work mat 3 040 x 640 mm	Work mat 3 040 x 940 mm
Article no.	6800000	6800005	6800001	6800006
Thickness	14 mm	14 mm	14 mm	14 mm
Colour	anthracite	anthracite	anthracite	anthracite
Temperature resistant	-35 °C to +95 °C	-35 °C to +95 °C	-35 °C to +95 °C	-35 °C to +95 °C
Fire classification	B1 as per DIN 4102	B1 as per DIN 4102	B1 as per DIN 4102	B1 as per DIN 4102
Dimensions	1 840 x 640 mm	1 840 x 940 mm	3 040 x 640 mm	3 040 x 940 mm
Weight	6 kg	9 kg	10.5 kg	15 kg

Machine vices MSO with prisms

- › Easy action
- › Spindle with rolled trapezoid thread
- › Many assembly options on drill table thanks to slots

MSO 75	3000075
MSO 100	3000100
MSO 125	3000125
MSO 150	3000150

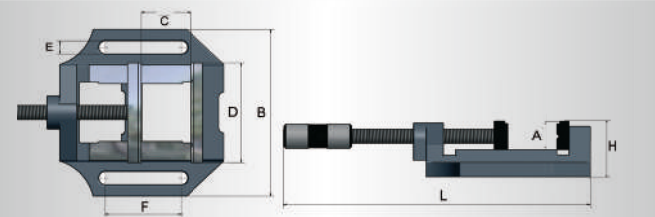

Tech. data	A	C	D	E	F	L	B	H	kg
MSO 75 mm	28	55	75	12.5	55	270	130	52	2.3
MSO 100 mm	28	90	100	12.5	74	350	165	55	3.2
MSO 125 mm	30	110	125	12.5	80	400	182	65	4.5
MSO 150 mm	35	130	150	14.5	110	455	208	67	6.2



MSO 100

Machine vices BSI

- › Drill vices in industrial quality
- › Replaceable prism jaws
- › Long guides on moving jaw prevent tilting
- › Precision ground prism jaws
- › Many assembly options on drill table thanks to slots
- › Premium grey cast
- › Scraped guide surfaces

BSI 100	3000210
BSI 140	3000214
BSI 200	3000220

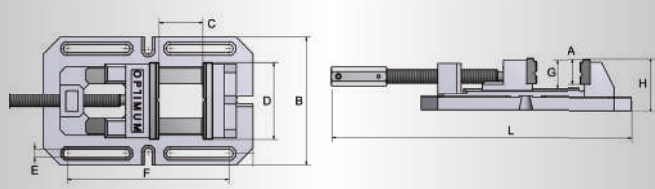

Tech. data	A	C	D	E	F	G	L	B	H	kg
BSI 100 mm	35	110	100	12	216	40	max. 460	170	74	8.7
BSI 140 mm	45	150	140	14	290	50	max. 610	230	93	18
BSI 200 mm	58	200	200	16	406	64	max. 788	290	118	20



BSI 140

Machine vices BMS with prisms

- › Rugged design with prism jaws
- › Easy action
- › Precise jaw guidance
- › Spindle with rolled trapezoid thread
- › Many assembly options on drill table thanks to slots

BMS 85	3000008
BMS 100	3000010
BMS 120	3000012
BMS 150	3000015
BMS 200	3000020

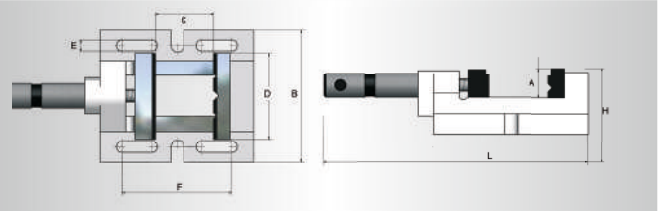

Tech. data	A	C	D	E	F	L	B	H	kg
BMS 85 mm	27	70	85	11	109	260	130	60	3.2
BMS 100 mm	30	90	100	12.5	125	280	150	66	4.6
BMS 120 mm	35	110	120	12.5	146	330	170	70	5.6
BMS 150 mm	45	130	150	12.5	180	375	200	78	7.6
BMS 200 mm	60	160	200	12.5	210	445	252	95	16



BMS 85

Machine vices BSI-Q

- › Drill vices in industrial quality
- › Quick clamping thanks to quick release
- › Replaceable prism jaws
- › Long guides on moving jaw prevent tilting
- › Precision ground prism jaws
- › Many assembly options on drill table thanks to slots
- › Premium grey cast . Scraped guide surfaces

BSI-Q 100	3000230
BSI-Q 140	3000234
BSI-Q 200	3000240

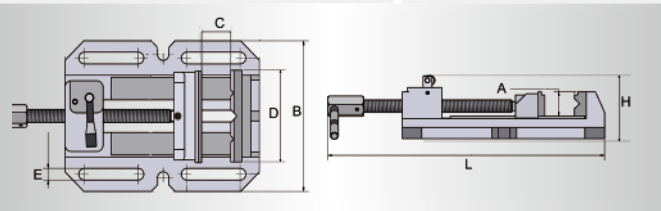

Tech. data	A	C	D	E	L	B	H	kg
BSI-Q 100 mm	30	105	100	12	max. 335	150	95	8.9
BSI-Q 140 mm	40	155	140	14	max. 415	200	100	18.2
BSI-Q 200 mm	55	220	200	16	max. 525	275	125	20.2



BSI-Q 100



The solution for loose rivet nuts

Secure threaded connections for thin wall thicknesses

THERMDRILL®

Verbindungstechnik – Made in Germany

The Thermdrill® method

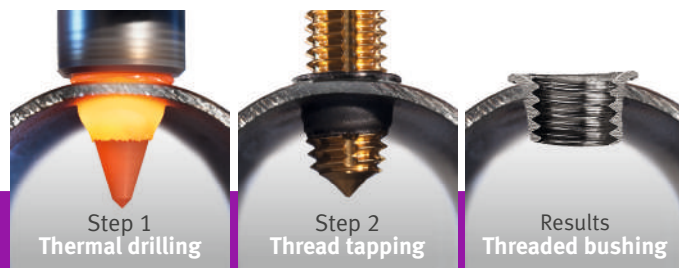

In thermal drilling, the friction heat from the existing material is used to create an anti-twist protected bushing without material removal in which a thread is then tapped.

- For aluminium, brass, copper, steel, stainless steel as of 1.0 mm wall thickness
- For use with milling cutters, CNC systems and Upright drills

www.thermdrill.com

✓ Cost savings

✓ Time savings

✓ Maximum safety

Thermal drill



SHAPE

For bushes with collars



CUT

For bushes without collars

- Suitable for aluminium, non-ferrous metal, steel and stainless steel. Made of solid carbide with a special polygon grind

Size	Type	Max. material thickness [mm]	Art. no.	Max. material thickness [mm]	Art. no.
M4	short	1.5	3060104	2.0	3060164
	long	2.5	3060124	4.0	3060144
M5	short	2.0	3060105	3.0	3060165
	long	3.0	3060125	4.5	3060145
M6	short	2.0	3060106	3.0	3060166
	long	3.5	3060126	5.0	3060146
8M	short	2.5	3060108	4.0	3060168
	long	4.0	3060128	6.0	3060148
M10	short	2.5	3060110	4.0	3060170
	long	4.5	3060130	6.5	3060150
M12	short	2.5	3060112	4.0	3060172
	long	4.5	3060132	6.5	3060152

Other thread sizes available (also in metric fine and pipe threads)

Thread tapper



TiN coated and with lubrication grooves
Tolerance 6HX
Shape C

- Legacy tool fittings can be used

Size	Art. no.
M4 x 0.7	3060184
M5 x 0.8	3060185
M6 x 1.0	3060186
M8 x 1.25	3060188
M10 x 1.25	3060190
M12 x 1.25	3060192

Basic equipment



Contains everything you need to get started with the THERMDRILL right away

	Art. no.
MT 2	3060005

Contents:

- ▶ THERMDRILL Paste 100 g
- ▶ Thread tapping oil 100 ml
- ▶ Open-end wrench
- ▶ Hook wrench
- ▶ Tool holder with cooling ring MT 3
- ▶ Case
- ▶ Reduction sleeve MT 3 - MT 2
- ▶ Spring collets (Ø 6/8/10/12 mm)

Tool set = Thermal drill + thread tapper

Type SHAPE				Type CUT	
Size	Type	Max. material thickness [mm]	Art. no.	Max. material thickness [mm]	Art. no.
M4	short	1.5	3060024	2.0	3060044
	long	2.5	3060034	4.0	3060054
M5	short	2.0	3060025	3.0	3060045
	long	3.0	3060035	4.5	3060055
M6	short	2.0	3060026	3.0	3060046
	long	3.5	3060036	5.0	3060056
8M	short	2.5	3060028	4.0	3060048
	long	4.0	3060038	6.0	3060058
M10	short	2.5	3060030	4.0	3060050
	long	4.5	3060040	6.5	3060060
M12	short	2.5	3060032	4.0	3060052
	long	4.5	3060042	6.5	3060062

THERMDRILL Paste

Container	Art. no.
For friction drilling including brush	
1 kg	3060090

Protects the thermal drill against excessive wear.

Thread tapping oil

Container	Art. no.
Including brush	
1 litre	3060092

High-performance oil, specially suited for thread tapping in aluminium, copper, brass, steel, stainless steel



New at OPTIMUM



Core drills and core drilling technology

Core drilling is an extremely economical process because it is faster, quieter and more precise than twist drilling.

Core drilling technology for versatile applications such as drilling in steel girders, drilling magnetic, multilayer materials or staggered drilling.

MAGNETIC DRILLING MACHINES

Magnetic core drilling machine with continuously variable speed, when you need reliability, precision and economy at work

Facts that impress in terms of quality, performance and price

- ▶ Safe switch arrangement
- ▶ All frames made of pressure cast magnesium, light weight.
- ▶ Stable drilling guidance thanks to long and especially deep mounted spindle sleeve holder
- ▶ Device is earthed and double insulated, hence ideal for building sites
- ▶ High magnetic holding force
- ▶ Automatic internal lubrication, the coolant is routed directly to the tip of the core bit
- ▶ High-quality mechanical design
- ▶ Conversion from core to full drilling in just a few actions
- ▶ Internal self-lubrication function ensures a longer service life of the gear unit.

Motor

- › Powerful motor with high torque and low-maintenance

Guides

- › Safe guides for stability and precision

Coolant tank

- › Detachable coolant tank
- › External fastening
- › Well-designed and practical

Handles

- › Ergonomic and rugged handles for "balanced" holding/fastening of the machine
- › Rugged crank handle

Spindle seat

- › MT collet
- › Weldon shank

Speed setting

- › continuously variable



Fig. DM 98V



Fig. DM 60V



- › Quick release drill chuck included

Technical data and accessories

Model	DM 60V	DM 98V
Article no.	3071160	3071198
Technical specifications		
Electrical connection	230 V / 1 Ph ~50 Hz	230 V / 1 Ph ~50 Hz
Motor output	1.89 kW	2.18 kW
Drilling performance		
Core drilling bit Ø max.	Ø 60 mm	Ø 98 mm
Core drilling bit depth max.	50 mm	75 mm
Twist drill bit Ø max.	Ø 23 mm	Ø 28 mm
Carriers		
Drill bit adapter	Weldon 3/4"	Weldon 3/4"
Spindle seat	MT 2	MT 3
Tool shank	Weldon shank Ø 19 mm	Weldon shank Ø 19 mm
Magnetic foot		
Magnetic foot dimensions	202 x 103 mm	202 x 103 mm
Magnetic attraction force	16 kN	17 kN
Speeds		
Speed without load	100 - 470 rpm Continuously variable	100 - 380 rpm Continuously variable
Dimensions		
Length x width x height	240 x 330 x 450 - 650 mm	240 x 330 x 450 - 650 mm
Weight	18.3 kg	18.5 kg

Scope of supply

- › Transport case
- › MK collet
- › Coolant tank
- › Safety chain
- › Quick release chuck
- › Tool



Transport case

- › For convenient transport and optimum protection

Core bit set HSS-TiAlN 30

Five HSS core bits and one TiAlN core bit
6-part

- For testing, including one 18 mm core bit featuring our highest quality level with TiAlN coating for a long service life and excellent cutting properties
- Set in a practical plastic case

Core bit set HSS-TiAlN 30 3072010

- › Five HSS core bits Ø 12, 14, 16, 20, 22 mm
- › One TiAlN core bit Ø 18 mm
- › Drilling depth 30 mm
- › One ejector pin



Core bit set TiAlN 30

Core bit with hard and smooth TiAlN coating
6-part

- TiAlN coating for a long service life and excellent cutting properties
- Set in a practical plastic case

Core bit set TiAlN 30 3072020

- › Six TiAlN core bits Ø 12, 14, 16, 18, 20, 22 mm
- › Drilling depth 30 mm
- › One ejector pin



Magnetic core drilling machine with permanent magnet impresses with amazing drilling performance

Facts that impress in terms of quality, performance and price

- ▶ Permanent magnet - independent of power source and thus 100% safe
- ▶ Magnetic foot with high holding force supports work on vertical surfaces and overhead
- ▶ Safe switch arrangement
- ▶ Stable drilling guidance thanks to long and especially deep mounted spindle sleeve holder
- ▶ Device is earthed and double insulated, hence ideal for building sites
- ▶ Soft-start is gentle on the motor and prolongs the service life
- ▶ Automatic internal lubrication, the coolant is routed directly to the tip of the core bit
- ▶ High-quality mechanical design
- ▶ Conversion from core to full drilling in just a few actions
- ▶ Internal self-lubrication function ensures a longer service life of the gear unit.
- ▶ External coolant tank for easy metering of internal core bit cooling
- ▶ Carrying handle for convenient carrying and lifting



Fig. DM 50PM

Model	DM 50PM
Article no.	3071550
Technical specifications	
Electrical connection	230 V / 1 Ph ~50 Hz
Motor output	1.75 kW
Drilling performance	
Core drilling bit Ø max.	Ø 50 mm
Core drilling bit depth max.	50 mm
Twist drill bit Ø max.	Ø 13 mm
Carriers	
Spindle seat	Weldon 3/4"
Drill bit adapter	Fixed
Tool shank	Weldon shank Ø 19 mm
Magnetic foot	
Magnetic foot dimensions	165 x 83 mm
Magnetic attraction force	16.5 kN
Speeds	
Speed without load	750 rpm
Dimensions	
Length x width x height	220 x 250 x 380 - 530 mm
Weight	11.7 kg

Scope of supply
› Metal case
› Coolant tank
› Safety belt
› Tool

Metal case
› For optimal protection

Accessories	Article no.
Core bit set HSS-TiAlN 30	3072010
› Five HSS core bits and one TiAlN core bit	
Core bit set TiAlN 30	3072020
› Six TiAlN core bits	

Arguments



Permanent magnet

- › Independent of power source and thus 100% safe



Coolant tank

- › Detachable coolant tank
- › External fastening
- › Well-designed and practical



Switch arrangement

- › Clear cut controls

Powerful multifunctional magnetic core drilling machine with thread tapping function for professional deployment in industry and trades.

Facts that impress in terms of quality, performance and price

- ▶ Safe switch arrangement
- ▶ Oil gearbox for long service life
- ▶ Dual dovetail guides
- ▶ Direction of rotation change through electronic pushbutton
- ▶ Stable drilling guidance thanks to long and especially deep mounted spindle sleeve holder
- ▶ Device is earthed and double insulated, hence ideal for building sites
- ▶ High magnetic holding force
- ▶ Automatic internal lubrication, the coolant is routed directly to the tip of the core bit
- ▶ High-quality mechanical design
- ▶ Conversion from core to full drilling in just a few actions
- ▶ Safe and reliable function
- ▶ MK collet



Fig. DM36VT

Model	DM 36VT
Article no.	3071236
Technical specifications	
Electrical connection	230 V / 1 Ph ~50 Hz
Motor output	1.55 kW
Drilling performance	
Core drilling bit Ø max.	Ø 36 mm
Core drilling bit depth max.	35 mm
Twist drill bit Ø max.	Ø 18 mm
Thread tapping bit Ø max.	M15
Carriers	
Spindle seat	Fixed
Drill bit adapter	MT 2
Magnetic foot	
Magnetic foot dimensions	166 x 80 mm
Magnetic attraction force	14.2 kN
Speeds	
Speed without load	100 - 340/640 rpm Continuously variable
Dimensions	
Length x width x height	220 x 250 x 380 - 530 mm
Weight	12 kg

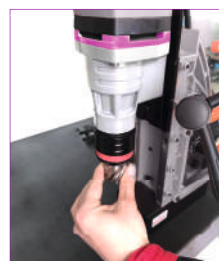

▶ Quick clamping drill chuck included



Scope of supply

- ▶ Transport case
- ▶ Coolant tank
- ▶ Safety belt
- ▶ Tool
- ▶ Quick release chuck

Multifunctional



▶ Thread tapping



▶ Countersinking



▶ Twist drilling



▶ Core drilling



▶ End milling cutters

Premium magnetic core drill machine offers maximum feature set. DM 35PF with automatic spindle sleeve feed and return

Facts that impress in terms of quality, performance and price

- ▶ Stable drilling guidance thanks to long and especially deep mounted spindle sleeve holder
- ▶ The devices are earthed and double insulated, hence ideal for building sites
- ▶ High magnetic holding force
- ▶ Overload protection
- ▶ Soft-start is gentle on the motor and prolongs the service life
- ▶ Automatic internal lubrication, the coolant is routed directly to the tip of the core bit
- ▶ High-quality mechanical design
- ▶ Conversion from core to full drilling in just a few actions

- ▶ Internal self-lubrication function for a longer service life of the gear unit.
- ▶ The magnetic foot has a wear-proof design to extend the service life of the magnetic base and thus the maximum magnetic holding force

DM 35PF

- ▶ Spindle sleeve feed
- ▶ Automatic return to starting position
- ▶ Quick clamping chuck in standard scope of delivery

Motor

- › Powerful motor with high torque and low-maintenance

Coolant tank

- › Detachable coolant tank
- › External fastening
- › Well-designed and practical

Guides

- › Safe guides for stability and precision

Housing

- › Compact and robust

Handles

- › Ergonomic and rugged handles for "balanced" holding/fastening of the machine.
- › Rugged crank handle

DM 35PF only

- › Spindle sleeve feed
- › Controlled return to starting position



Fig. DM 35PF



Fig. DM 50



DM 35PF only

- › Quick release chuck

Technical data and accessories

Model	DM 35	DM 50	DM 35PF
Article no.	3071035	3071050	3071435
Technical specifications			
Electrical connection	230 V / 1 Ph ~50 Hz	230 V / 1 Ph ~50 Hz	230 V / 1 Ph ~50 Hz
Motor output	1.6 kW	1.75 kW	1.6 kW
Drilling performance			
Core drilling bit Ø max.	Ø 35 mm	Ø 50 mm	Ø 38 mm
Core drilling depth max.	35 mm	50 mm	35 mm
Twist drill bit Ø max.	Ø 13 mm	Ø 13 mm	-
Carriers			
Spindle seat	Fixed	Fixed	Fixed
Drill bit adapter	Weldon 3/4"	Weldon 3/4"	Weldon 3/4"
Tool shank	Weldon shank Ø 19 mm	Weldon shank Ø 19 mm	Weldon shank Ø 19 mm
Magnetic foot			
Magnetic foot dimensions	166 x 80 mm	166 x 80 mm	166 x 80 mm
Magnetic attraction force	13.8 kN	14.5 kN	16 kN
Speeds			
Speed without load	900 rpm	750 rpm	900 rpm
Dimensions			
Length x width x height	255 x 280 x 410 - 470 mm	250 x 220 x 300 - 470 mm	220 x 250 x 380 - 530 mm
Weight	10.5 kg	10.6 kg	14 kg

Scope of supply

- › Coolant tank
- › Safety belt
- › Tool
- › DM 35 PF quick release chuck



- Transport case (DM 35/DM 50)
- Metal box (DM 35PF)
- › For optimal protection

Core bit set HSS-TiAlN 30

Five HSS core bits and one TiAlN core bit
6-part

- For testing, including one 18 mm core bit featuring our highest quality level with TiAlN coating for a long service life and excellent cutting properties
- Set in a practical plastic case

Core bit set HSS-TiAlN 30 3072010

- › Five HSS core bits Ø 12, 14, 16, 20, 22 mm
- › One TiAlN core bit Ø 18 mm
- › Drilling depth 30 mm
- › One ejector pin



Core bit set TiAlN 30

Core bit with hard and smooth TiAlN coating
6-part

- TiAlN coating for a long service life and excellent cutting properties
- Set in a practical plastic case

Core bit set TiAlN 30 3072020

- › Six TiAlN core bits Ø 12, 14, 16, 18, 20, 22 mm
- › Drilling depth 30 mm
- › One ejector pin



Premium magnetic core bit drilling machines with continuously variable speed control offer maximum feature set

Facts that impress in terms of quality, performance and price

- ▶ High performance with a compact size and low weight
- ▶ Stable drilling guidance thanks to long and especially deep mounted spindle sleeve holder
- ▶ Device is earthed and double insulated, hence ideal for building sites
- ▶ Automatic internal lubrication: the coolant is routed directly to the tip of the core bit
- ▶ Conversion from core to full drilling in just a few actions
- ▶ Safe and reliable function
- ▶ Internal self-lubrication function ensures a longer service life of the gear unit.
- ▶ High magnetic holding force
- ▶ Magnetic foot has a wear-proof design to extend the service life of the magnetic base and thus the maximum magnetic holding force



Scope of supply

- › Transport case
- › Operating tool
- › Safety belt
- › Quick release chuck

Fig. DM 50V

Model	DM 35V	DM 50V
Article no.	3071135	3071150
Technical specifications		
Electrical connection	230 V / 1 Ph ~50 Hz	230 V / 1 Ph ~50 Hz
Motor output	1.55 kW	1.7 kW
Drilling performance		
Core drilling bit Ø max.	Ø 35 mm	Ø 50 mm
Core drilling depth max.	35 mm	50 mm
Twist drill bit Ø max.	Ø 13 mm	Ø 13 mm
Carriers		
Spindle seat	Fixed	Fixed
Drill bit adapter	Weldon 3/4"	Weldon 3/4"
Tool shank	Weldon shank Ø 19 mm	Weldon shank Ø 19 mm
Magnetic foot		
Magnetic foot dimensions	166 x 80 mm	166 x 80 mm
Magnetic attraction force	14.8 kN	15.6 kN
Speeds		
Speed without load	100 - 800 rpm Continuously variable	100 - 670 rpm Continuously variable
Dimensions		
Length x width x height	255 x 280 x 410-470 mm	250 x 220 x 300 - 470 mm
Weight	10.8 kg	11 kg

Arguments



Motor

- › Powerful motor with high torque and low-maintenance



Guides

- › Safe guides for stability and precision



Control panel

- › Ergonomic switch arrangement avoids confusion



Handles

- › Ergonomic and rugged handles for "balanced" holding/ fastening of the machine.
- › Rugged crank handle



Quick clamping chuck

- › For fast tool change

Accessories

Core bit set HSS-TiAlN 30

- › Five HSS core bits and one TiAlN core bit

Core bit set TiAlN 30

- › Six TiAlN core bits

Article no.

3072010

3072020

The magnetic drilling machine for working in cramped conditions. Impresses with compact and smart design



Facts that impress in terms of quality, performance and price

- ▶ The spur gear is designed for continuous operations
- ▶ Ideal for steel construction work, vehicle manufacturing, mechanical engineering, etc.
- ▶ High magnetic holding force for safe work
- ▶ Ergonomic single-handed operation thanks to clear-cut arrangement of controls
- ▶ Features safety belts for vertical or overhead applications as standard

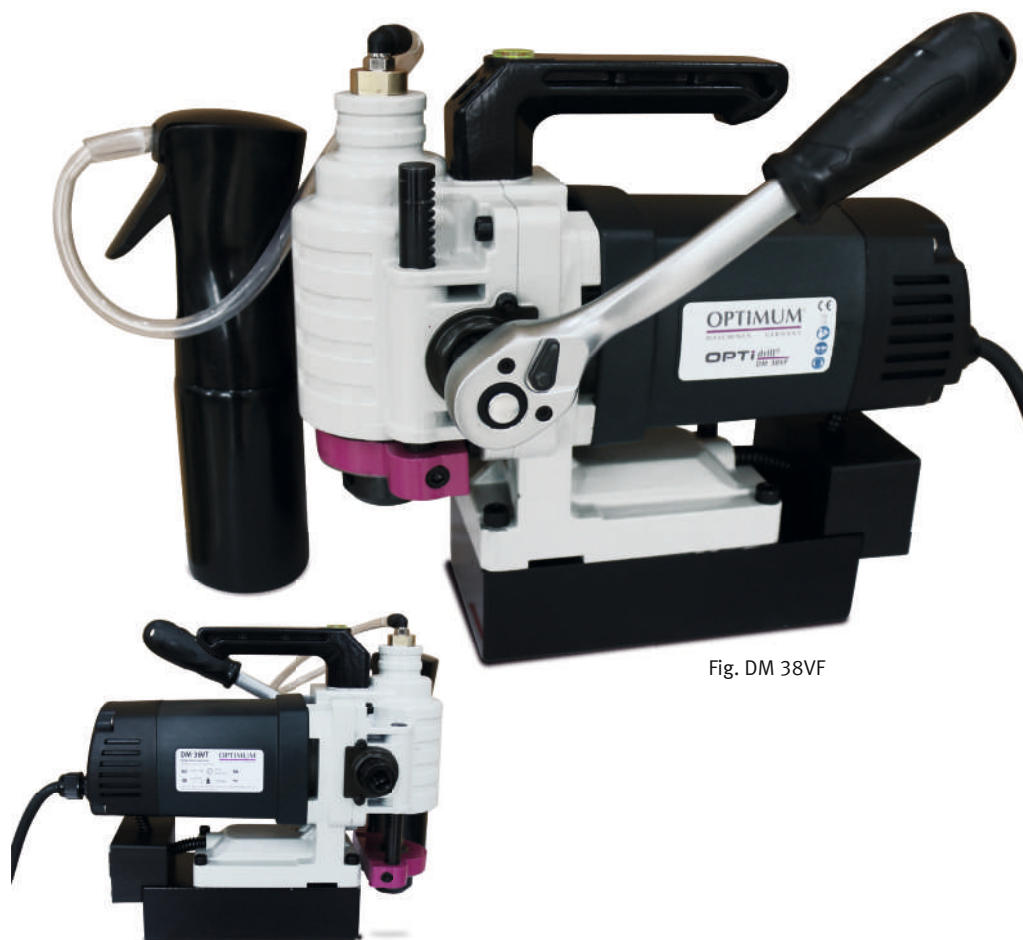

Fig. DM 38VF

Model	DM 38VF
Article no.	3071338
Technical specifications	
Electrical connection	230 V / 1 Ph ~50 Hz
Motor output	1.65 kW
Drilling performance	
Core drilling bit Ø max.	Ø 38 mm
Core drilling depth max.	35 mm
Carriers	
Spindle seat	Fixed
Drill bit adapter	Weldon 3/4"
Tool shank	Weldon shank Ø 19 mm
Magnetic foot	
Magnetic foot dimensions	156 x 80 mm
Magnetic attraction force	14.5 kN
Speeds	
Speed without load	660 rpm
Dimensions	
Length x width x height	250 x 350 x 240 mm
Weight	8.8 kg

Arguments



Pluggable handle

- › can be fitted on the left or right side of the machine as required



Magnetic holding force

- › Powerful magnet with 14.5 kN holding force



Compact





- › Machine weighs 8.8 kg
- › Practical dimensions, only 250x350x240 mm





Scope of supply

- › Transport case
- › Tool

Accessories

Accessories	Article no.
Core bit set HSS-TiAlN 30	3072010
› Five HSS core bits and one TiAlN core bit	
Core bit set TiAlN 30	3072020
› Six TiAlN core bits	

Model	DM 35	DM 35V	DM 50	DM 50V	DM 35PF
					
Drive motor output					
Rating	1.6 kW	1.55 kW	1.75 kW	1.7 kW	1.6 kW
Drill diameter					
Core bit maximum	Ø 35 mm	Ø 35 mm	Ø 50 mm	Ø 50 mm	Ø 38 mm
Drilling depth/Core drilling max.	35 mm	35 mm	50 mm	50 mm	35 mm
Spiral bit maximum	Ø 13 mm	Ø 13 mm	Ø 13 mm	Ø 13 mm	-
Magnet					
Magnetic attraction force	13.8 kN	14.8 kN	14.5 kN	15.6 kN	16 kN
Dimensions	166 x 80 mm	166 x 80 mm	166 x 80 mm	166 x 80 mm	166 x 80 mm
Machine weight	10.5 kg	10.8 kg	10.6 kg	11 kg	14 kg
Spindle speed	900 rpm	100 - 800 rpm	750 rpm	100 - 670 rpm	900 rpm
Spindle seat	Fixed	Fixed	Fixed	Fixed	Fixed
Drill bit adapter	Weldon 3/4"	Weldon 3/4"	Weldon 3/4"	Weldon 3/4"	Weldon 3/4"
Tool shank	Weldon shank Ø 19 mm	Weldon shank Ø 19 mm	Weldon shank Ø 19 mm	Weldon shank Ø 19 mm	Weldon shank Ø 19 mm
Vario drive		•		•	
Autom. spindle sleeve feed					•
Quick clamping chuck		•		•	•

Model	DM 36VT	DM 38VF	DM 50PM	DM 60V	DM 98V
					
Drive motor output					
Rating	1.55 kW	1.65 kW	1.75 kW	1.89 kW	2.18 kW
Drill diameter					
Core bit maximum	Ø 36 mm	Ø 38 mm	Ø 50 mm	Ø 60 mm	Ø 98 mm
Drilling depth/Core drilling max.	35 mm	35 mm	50 mm	50 mm	75 mm
Spiral bit maximum	Ø 18 mm	-	Ø 13 mm	Ø 23 mm	Ø 28 mm
Thread tapping maximum	M15	-	-	-	-
Magnet					
Magnetic attraction force	14.2 kN	14.5 kN	16.5 kN	16 kN	17 kN
Dimensions	166 x 80 mm	156 x 80 mm	165 x 83 mm	202 x 103 mm	202 x 103 mm
Machine weight	12 kg	8.8 kg	11.7 kg	18.3 kg	18.5 kg
Spindle speed	100-340/640 rpm	660 rpm	750 rpm	100 - 470 rpm	100 - 340 rpm
Number of speeds	Continuously variable	-	-	Continuously variable	Continuously variable
Spindle seat	Fixed	Fixed	Fixed	MT 2	MT 3
Drill bit adapter	MK2	Weldon 3/4"	Weldon 3/4"	Weldon 3/4"	Weldon 3/4"
Tool shank	-	Weldon shank Ø 19 mm	Weldon shank Ø 19 mm	Weldon shank Ø 19 mm	Weldon shank Ø 19 mm
Vario drive	•			•	•
Thread tapping	•				
Permanent magnet			•		
Quick clamping chuck	•			•	•



MILLING MACHINES



Machines with cast iron stands
Page 80 - 103



Bench-top model
Page 104 - 111



Entry-level class
Page 112 - 115

Tool milling machines with digital 3-axis position display DP 700 by NEWALL

TOP QUALITY

Facts that impress in terms of quality, performance and price

- ▶ Versatile range of applications
- ▶ Excellent damping characteristics and stability of machine chassis
- ▶ All guides tempered, precision ground, and adjustable using cleats
- ▶ X and Y axis with adjustable dovetail guide
- ▶ Automatic feed on X, Y and Z axis, continuously adjustable
- ▶ All axes with ball screws
- ▶ Central and clearly arranged control panel with integrated digital position and speed display
- ▶ Solid Cross table, generously dimensioned with precision surface finish and 5 T-slots
- ▶ Coolant system

- ▶ Control panel swivels centrally for a clear-cut overview
- ▶ Generously dimensioned hand wheels with scales
- ▶ Machine lamp
- ▶ Smooth action

MZ 2:

- ▶ Manual centralised lubrication system

MZ 4:

- ▶ Automatic centralised lubrication



Control Cabinet

- › External
- › Generously dimensioned
- › 24-V electrical system

Cross table housing

- › Supplied pre-assembled on the machine
- › Protection against chips and coolant
- › Folds away to allow optimal access to the workspace



Fig.: MZ4



Fig.: MZ 4 Figure shows machine without housing

OPTI Control panel

- › Integrated switch panel
- › Integrated digital position display DPA 700



Technical data and accessories

Model	MZ 2	MZ 4
Article no.	3346220	3346240
Technical specifications		
Electrical connection	400 V / 3 Ph ~50 Hz	
Total rated value	4 kW	5.4 kW
Drive motor	2.2 kW	3.75 kW
Motor rapid motion/feed	0.375 kW	0.75 kW
Coolant pump motor	95 W	
Drilling/milling output		
Drilling performance in steel (S235JR)	Ø 30 mm	Ø 32 mm
Continuous drilling performance in steel (S235JR)	Ø 26 mm	Ø 28 mm
Max. sensor head size	Ø 100 mm	Ø 100 mm
Max. shaft milling cutter size	Ø 25 mm	Ø 25 mm
Spindle drive		
Spindle speeds	50 - 1 890 rpm	30 - 2 250 rpm
Speeds	12 speeds	18 speeds
Spindle seat	ISO 40 DIN 2080	
Vertical		
Spindle sleeve stroke	120 mm	
Draw-in rod	M16	
Throat	max. 100 mm	max. 185 mm
Vertical rotation area	± 90°	
Clearance vertical spindle to cross table	75 - 410 mm	130 - 530 mm
Vertical Length x width	830 x 250 mm	1 200 x 250 mm
Max. load bearing capacity	385 kg	500 kg
T-slot size / spacing / count	14 mm / 63 mm / 2	14 mm / 63 mm / 3
Horizontal		
Clearance horizontal spindle to cross table	70 - 400 mm	130 - 390 mm
Horizontal Length x width	750 x 320 mm	900 x 500 mm
Max. load bearing capacity	385 kg	500 kg
T-slot size / spacing / count	14 mm / 63 mm / 5	14 mm / 63 mm / 7
Stroke during feed		
X axis (Cross table)	manual 400 mm / automatic 360 mm	manual 600 mm / automatic 560 mm
Y axis (milling head)	manual 200 mm / automatic 160 mm	manual 480 mm / automatic 440 mm
Z axis (Cross table)	manual 365 mm / automatic 325 mm	manual 385 mm / automatic 345 mm
Drive speed feed/rapid motion	50 - 450 rpm / 700 rpm	50 - 450 rpm / 800 rpm
Feed speed	10 / 600 mm/min.	10 / 600 mm/min.
Dimensions		
Length x width x height	1 239 x 1 168 x 1 900 mm	1 610 x 1 825 x 1 885 mm
Weight	1 180 kg	1 450 kg

Angled table	3346221
Table length x width/load bearing capacity max.	375 x 660 mm / 150 kg
T-Slot size / no / distance	12 mm / 8 / 45 mm
Dimensions	895 x 433 x 354 mm
Weight	140 kg

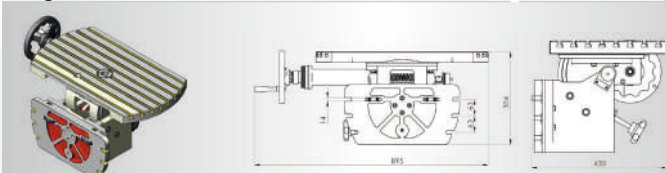

Accessories	Article no.
Collet chuck ISO 40/ER32	3352056
Hydraulic clamping device DIN69871* ex works only	3346226
Compressed air tool changer Can only be ordered ex works	3346225
Assortment of clamping tools size 12, 58 parts	3352017

> **More accessories for milling machines** from page 122

Scope of supply

- > 4 x arbour ISO 40 with counter-bearing
- 16 mm external diameter
- 22 mm external diameter
- 27 mm external diameter
- 32 mm external diameter
- > Adapter ISO40 - MK3
- > MT 2 collet
- > MT 1 collet
- > Operating tool



Vices	Article no.
MVSP 150 x 200	3530104
MVSP 150 x 300	3530108

> **Information about vices** from page 116

* Important information on transport surcharge and lump sum and „Operation of machines with frequency converters“ on page 249
The milling machines (frequency inverters) comply with standard DIN EN 55011:2011-04 class C3

Multifunctional drilling/milling machine with tool clamping system for professional deployment. With digital 3-axis position display DPA 2000

Facts that impress in terms of quality, performance and price

- ▶ Heavy, solid design using premium cast meehanite
- ▶ Smooth action due to polished gearwheels running in an oil sump
- ▶ 20 switchable speeds thanks to two-speed motor in combination with 5 belt stages and reduction gearbox
- ▶ Sturdy, square guide rails on Y and Z axis
- ▶ Solid Cross table, generously dimensioned with precision surface finish
- ▶ All axes adjustable in guides using cleats
- ▶ Detachable cross table housing for protection against chips and coolant
- ▶ Excellent concentricity thanks to tapered roller bearings, better than 0.01 mm measured in the spindle sleeve
- ▶ Coolant system
- ▶ Adjustable drilling depth stop with millimetre scale, can be read off on front
- ▶ LED machine lamp
- ▶ Chip tray
- ▶ Siemens electric
- ▶ Right-handed/left-handed rotation for thread tapping

Compressed air tool clamping system

- › Short change times
- › Low weight thanks to optimised structure
- › Precise guiding thanks to optimised geometry
- › Lowest air consumption



Horizontal milling position

- › with arrester and collet for disc milling cutter
- › Adjustable plain bearing

Vertical milling position

- › E.g., for milling V-ledges along the X axis



Fig.: MT 8 with horizontal and vertical milling position



Technical data and accessories

Model	MT 8
Article no.	3336088
Technical data	
Electrical connection	400 V / 3 Ph ~50 Hz
Total rated value	7.2 kW
Vertical spindle drive motor	5.5 kW
Horizontal spindle drive motor	4 kW
Coolant pump motor	90 W
Total rated value for compressed air	min. 6 bar
Drilling/milling output	
Drilling performance in steel (S235JR)	Ø 30 mm
Continuous drilling performance in steel (S235JR)	Ø 21 mm
Max. sensor head size	Ø 80 mm
Max. shaft milling cutter size	Ø 25 mm
Vertical spindle	
Spindle sleeve stroke	140 mm
Spindle sleeve feed	3 speeds: 0.086 - 0.142 mm
Spindle seat	ISO 40 DIN 2080
Spindle speeds	60 - 4 660 rpm
Speeds	20 speeds
Milling head tilt angle	± 45°
Horizontal spindle	
Spindle seat	ISO 50 DIN 2080
Spindle speeds	58 - 1 800 rpm
Speeds	12 speeds
Cross table	
Clearance spindle to table	155 - 610 mm
Length x width	1 320 x 360 mm
Table feed (9 speeds)	15 / 370 mm/min.
T-Slot size / no / distance	18 mm / 3 / 80 mm
Max. load bearing capacity	350 kg
X axis	
Travel	manual 980 mm / automatic 900 mm
Table feed	15 / 370 mm/min.
Y axis	
Travel	manual 300 mm / automatic 220 mm
Table feed	15 / 370 mm/min.
Y boom swivel range	± 30°
Z axis	
Travel	manual 450 mm / automatic 370 mm
Dimensions	
Length x width x height	2 220 x 2 060 x 2 550 mm
Weight	2 500 kg

Scope of supply
> Quick clamping drill chuck Ø 1 - 16 mm / B18
> Adapter 7:24 ISO 50 - MT 3
> Adapter 7:24 ISO 50 - MT 2
> Arbor for drill chuck 7:24 ISO 40 / B18
> 1 each cutter spindle horizontal milling Ø27 / Ø32 mm
> Milling chuck set Ø 4 - Ø 16 mm
> Operating tool

Accessories	Article no.
Assortment of clamping tools size 16, 58-parts	3352017
Collet chuck set 18-part ISO 40	3352056
Collet chuck set 18-part ISO 50	3352065
Precision machine shoe SEU1 (4 pcs. required) see page 128	3352985
Blank holder set of 2 18 mm/M16	3352032
Morse cone ISO50 B18 DIN2080	3352067
Milling head holder SK 50	3352066
Arbor for drill chuck ISO 40 / B16	3352070
Copying and facing blade head ISO 40 DIN 2080	3350216
Precision bore head set ISO 40	3352128
Precision bore head set ISO 50	3352129
> More accessories for milling machines from page 122	

Machine vices	Article no.
FMS 200	3354200
HMS 150	3355150
FMSN 150	3354130
VMQ 150	3354183
MV3-75	3354175
MV3-125	3354178
ZAS 50	3354170
DAS 100	3355500
HCV 105	3536210
HCV 125	3536214
> Information about vices from page 116	

* Important information on transport surcharge and lump sum see page 251

Preface

Drilling

Milling

Turning

Saws

Grinding

Polishing

Lamps

Measuring

Versatility and easy retooling - the universal milling machine for workshops with digital 3-axis position display

Facts that impress in terms of quality, performance and price

- ▶ Versatile range of applications
- ▶ Rugged machine construction
- ▶ Smooth action due to polished gearwheels running in an oil sump
- ▶ Heavy, solid design using premium cast meehanite
- ▶ All guides tempered and adjustable using cleats
- ▶ Central lubrication
- ▶ Generously dimensioned hand wheels with scales
- ▶ LED machine lamp
- ▶ Coolant system
- ▶ Easy operation of the switching elements
- ▶ Rugged, rectangular guide rails on Y and Z axis
- ▶ Table feed X, Y and Z axis automatic

- ▶ Digital position display DPA 21
- ▶ Feed system controllable by servomotor in fixed steps
- ▶ Decoupled hand wheels
- ▶ Solid and generously dimensioned cross table with precision surface finish including adjustable cleats and end stops
- ▶ Horizontal milling position
- ▶ Horizontal milling counterholder, attached to rear of machine for easy access
- ▶ Milling head with two axes of rotation, thus pivots and rotates to any spatial angle

OPTI Control panel

- > Integrated switch panel
- > Integrated digital position display
- > Rotates about its own axis

Horizontal milling position

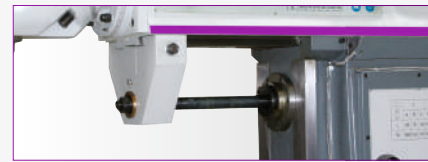

- ▶ For work in horizontal milling position with arrester and collet for disc milling cutter
- ▶ Adjustable plain bearing

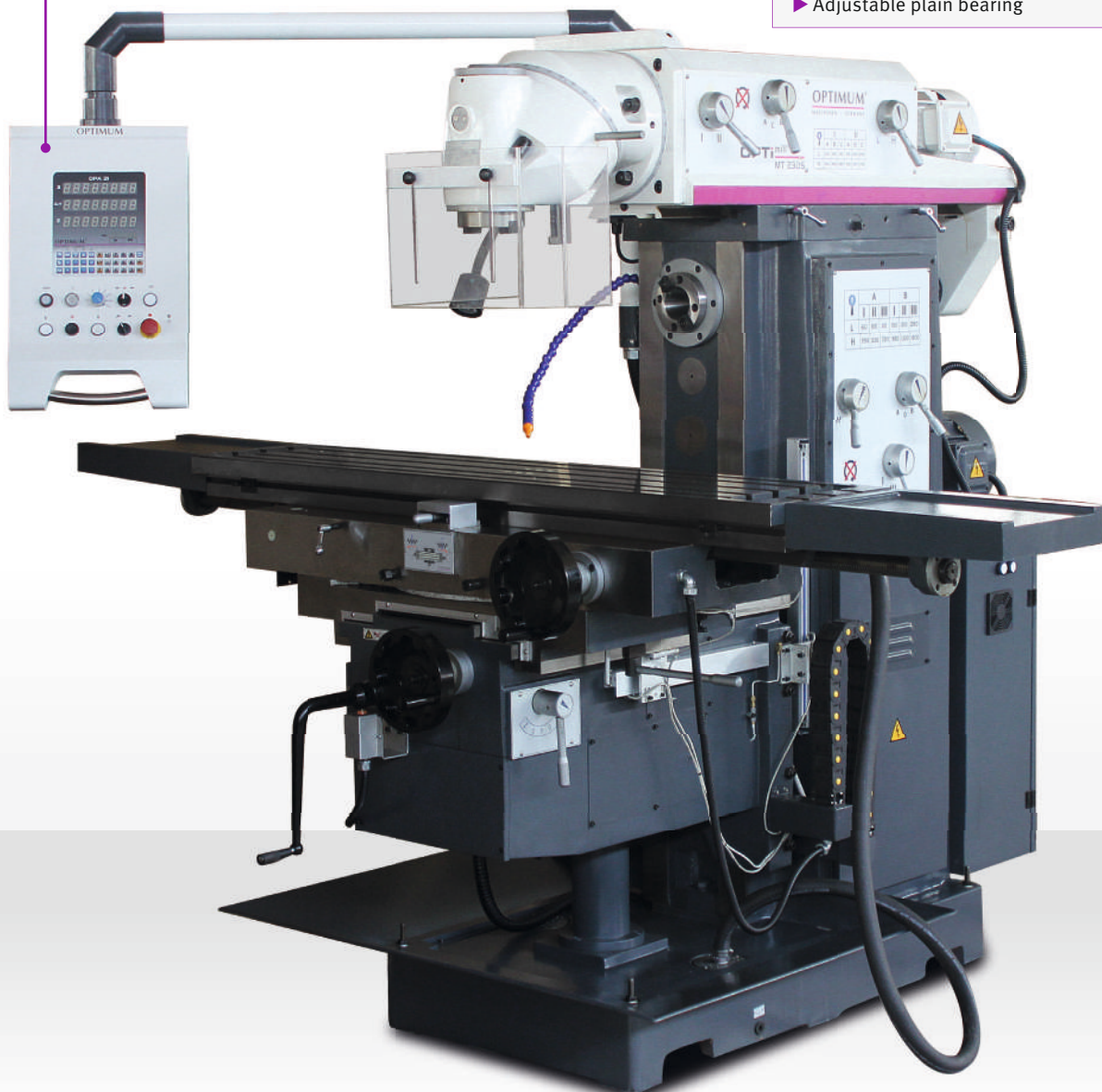

Fig.: MT 230S

*OPTImill® is a registered brand of Optimum Maschinen Germany GmbH and exclusively used for milling machines

Technical specifications, accessories and dimensions

Model	MT 230S
Article no.	3344125
Technical specifications	
Electrical connection	400 V / 3 Ph ~50 Hz
Total rated value	12 kW
Vertical drive motor	4 kW
Horizontal drive motor	5.5 kW
Coolant pump output	90 Watts
Milling capacity	
Max. sensor head size	Ø 160 mm
Max. shaft milling cutter size	Ø 25 mm
Spindle	
Spindle seat	ISO 50 DIN 2080
Vertical	
Draw-in rod	M24
Spindle speeds	60 - 1 750 rpm
Speeds	12 speeds
Clearance spindle to cross table	190 - 590 mm
Distance spindle to column	260 - 910 mm
Milling head tilt angle	360°
Horizontal	
Clearance spindle to cross table	20 - 420 mm
Spindle speeds	60 - 1 800 rpm
Speeds	12 speeds
Cross table	
Length x width	1 600 x 360 mm
Max. load bearing capacity	400 kg
T-Slot size / no / distance	18 mm / 3 / 80 mm
Rotating	35°
X axis	
Travel	manual 1 300 mm / automatic 1 220 mm
Table feed automatic	30 - 750 mm/min.
Table feed rapid motion	1 200 mm/min
Y axis	
Cross table stroke	manual 300 mm / automatic 220 mm
Table feed automatic	20 - 500 mm/min.
Table feed rapid motion	800 mm/min
Z axis	
Travel	manual 400 mm / automatic 320 mm
Table feed automatic	15 - 375 mm/min.
Table feed rapid motion	600 mm/min
Dimensions	
Length x width x height	2 520 x 2 160 x 2 030 mm
Overall weight	2 800 kg

Accessories	Article no.
Parallel shim set, 20-part	3354001
Assortment of clamping tools size 16, 58-parts	3352017
Collet chuck set ISO 50/ER32	3352065
Precision machine shoe SEU1 (4 pcs. required) see page 128	3352985
Blank holder set of 2 18 mm/M16	3352032
Morse cone ISO50 B18 DIN2080	3352067
Precision bore head set ISO 50	3352129
› More Accessories from page 122	

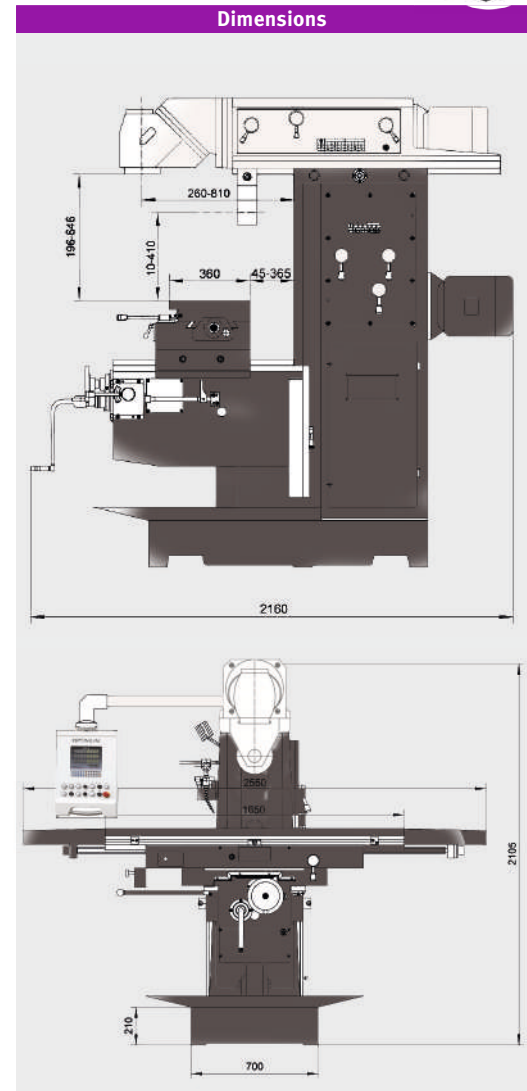

Scope of supply

- › Cutter spindle horizontal milling ISO 50 Ø 22 mm
- › Cutter spindle horizontal milling ISO 50 Ø 27 mm
- › Milling head holder ISO 50 Ø 40 mm
- › Adapter ISO 50 (7:24) / MK4
- › Collet chuck ISO 50 Ø 4 - Ø 16 mm
- › Horizontal and vertical tie rod M24
- › Spring collets Ø 4 - Ø 26 mm
- › Operating tool

Machine vices	Article no.
FMS 200	3354200
HMS 125	3355127
MV3-75	3354175
MV3-125	3354178
ZAS 50	3354170
DAS 100	3355500
HCV 105	3536210
HCV 125	3536214
› Information about vices from page 116	

* Important information on transport surcharge and lump sum and „Operation of machines with frequency converters“ on page 249
The milling machines (frequency inverters) comply with standard DIN EN 55011:2011-04 class C2

Versatility and easy retooling - the universal milling machine for workshops with digital 3-axis position display

Facts that impress in terms of quality, performance and price

- ▶ Versatile range of applications
- ▶ Heavy, solid design using premium cast meehanite
- ▶ Vertical and horizontal milling position
- ▶ Rugged machine construction
- ▶ Milling head pivots and rotates to any spatial angle
- ▶ Smooth action due to polished gearwheels running in an oil sump
- ▶ Milling head with two axes of rotation, thus pivots and rotates to any spatial angle
- ▶ Counterholder for horizontal milling attached to rear for easy access
- ▶ All guides tempered and adjustable using cleats
- ▶ Central lubrication
- ▶ Generously dimensioned, decoupled hand wheels with scales
- ▶ LED machine lamp
- ▶ Coolant system
- ▶ Easy operation of the switching elements
- ▶ Sturdy, square guide rails on Y and Z axis
- ▶ Height-adjustable protective screen with microswitch for best possible user protection against chips and parts being flung out
- ▶ Solid and generously dimensioned cross table with precision surface finish and T-slots
- ▶ Table feed X, Y and Z axis
- ▶ Digital position display DPA 2000
- ▶ Feed motor with fixed speeds



OPTI Control panel

- > Integrated switch panel
- > Integrated **digital position display**
- > Rotates about its own axis

Horizontal milling position

- > with arrester and collet for disc milling cutter
- > Adjustable plain bearing

Vertical milling position

- > E.g., for milling V-ledges along the X axis



Fig.: MT 200

Technical specifications, accessories and dimensions

Model	MT 200
Article no.	3336120
Technical data	
Electrical connection	400 V / 3 Ph ~50 Hz
Total rated value	9.2 kW
Horizontal and vertical drive motor	4 kW
Feed motor output	1.1 kW
Coolant pump motor	90 Watts
Milling capacity	
Max. sensor head size	Ø 100 mm
Max. shaft milling cutter size	Ø 20 mm
Spindle	
Horizontal and vertical spindle seat	ISO 50 DIN 2080
Vertical	
Draw-in rod	M24
Clearance spindle to cross table	250 - 670 mm
Distance spindle to column	250 - 750 mm
Spindle speeds	60 - 1 750 rpm
Speeds	12 speeds
Milling head tilt angle	360°
Horizontal	
Clearance spindle to cross table	0 - 420 mm
Spindle speeds	58 - 1 800 rpm
Speeds	12 speeds
Cross table	
Length x width	1 650 x 360 mm
Max. load bearing capacity	450 kg
T-Slot size / distance / no	14 mm / 95 mm / 3
Rotating	35°
X axis	
Travel	manual 1 209 mm / automatic 1 210 mm
Table feed automatic	22 - 380 mm/min.
Table feed, stages	8 speeds
Table feed rapid motion	1 290 mm/min.
Y axis	
Cross table stroke	manual 280 mm / automatic 200 mm
Table feed automatic	20 / 380 mm/min.
Table feed, stages	8 speeds
Table feed rapid motion	200 mm/min
Z axis	
Travel	manual 400 mm / automatic 320 mm
Table feed automatic	7 / 127 mm/min.
Table feed, stages	8 speeds
Table feed rapid motion	342 mm/min.
Dimensions	
Length x width x height	1 920 x 2 350 x 2 200 mm
Weight	2 220 kg

Accessories	Article no.
Parallel shim set, 20-part	3354001
Assortment of clamping tools size 12, 58-parts	3352017
Blank holder set of 2 14 mm/M12	3352031
Precision machine shoe SEU1 (4 pcs. required) see page 128	3352985
Morse cone ISO50 B18 DIN2080	3352067
› More accessories for milling machines from page 122	

* Important information on transport surcharge and lump sum see page 251

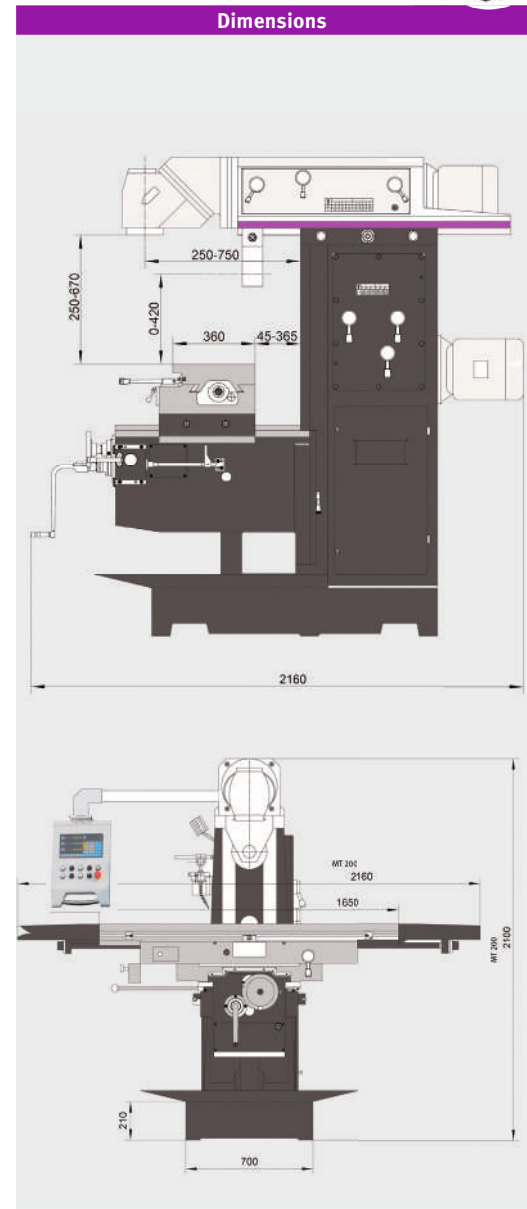

Scope of supply

- › Cutter spindle horizontal milling ISO 50 Ø 22 mm
- › Cutter spindle horizontal milling ISO 50 Ø 27 mm
- › Milling head holder ISO 50 Ø 32 mm
- › Collet chuck ISO 50 Ø 4 - Ø 26 mm
- › Operating tool

Machine vices	Article no.
FMS 200	3354200
HMS 125	3355127
MV3-75	3354175
MV3-125	3354178
ZAS 50	3354170
DAS 100	3355500
HCV 105	3536210
HCV 125	3536214
› Information about vices from page 116	

Preface

Drilling

Milling

Turning

Saws

Grinding

Polishing

Lamps

Measuring

Versatile and easy retooling. The universal milling machine for workshops

Facts that impress in terms of quality, performance and price

- ▶ Versatile range of applications
- ▶ Heavy, solid design using premium cast meehanite
- ▶ Vertical and horizontal milling position
- ▶ Rugged machine construction
- ▶ Milling head pivots and rotates to any spatial angle
- ▶ Smooth action due to polished gearwheels running in an oil sump
- ▶ All guides tempered and adjustable using cleats
- ▶ Central lubrication
- ▶ Generously dimensioned, decoupled hand wheels with scales
- ▶ LED machine lamp
- ▶ Coolant system
- ▶ Easy operation of the switching elements
- ▶ Sturdy, square guide rails on Y and Z axis
- ▶ Height-adjustable protective screen with microswitch for best possible user protection against chips and parts being flung out
- ▶ Solid and generously dimensioned cross table with precision surface finish and T-slots
- ▶ Digital position display DPA 21
- ▶ Feed system controllable by servomotor in fixed steps
- ▶ Table feed X, Y and Z axis

OPTi Control panel

- › Integrated switch panel
- › Integrated **digital position display DPA 21**
- › Rotates about its own axis

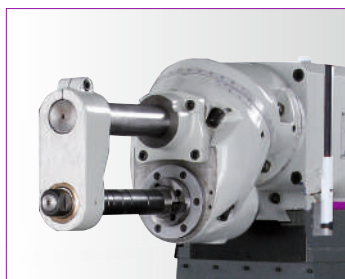

Horizontal milling position

- › with arrester and collet for disc milling cutter
- › Adjustable plain bearing

Vertical milling position

- › E.g., for milling V-ledges along the X axis



Fig.: MT 130S

Technical specifications, accessories and dimensions

Model	MT 130S
Article no.	3344110
Technical data	
Electrical connection	400 V / 3 Ph ~50 Hz
Total rated value	6 kW
Drive motor	3 kW
Feed motor output	3 kW
Coolant pump motor	60 Watt
Milling capacity	
Max. sensor head size	Ø 100 mm
Max. shaft milling cutter size	Ø 100 mm
Vertical	
Spindle seat	ISO 40 DIN 2080
Draw-in rod	M16
Clearance spindle to cross table	196 - 646 mm
Spindle speeds	45 - 1 660 rpm
Speeds	11 speeds
Throat	150 - 550 mm
Milling head tilt angle	360°
Cross table	
Length x width	1 270 x 300 mm
Max. load bearing capacity	200 kg
T-slot size / spacing / count	14 mm / 80 mm / 3
X axis	
Cross table stroke	manual 720 mm / automatic 650 mm
Table feed automatic	30 / 830 mm/min.
Rapid traverse	1 335 mm/min
Y axis	
Cross table stroke	manual 300 mm / automatic 220 mm
Table feed	30 / 830 mm/min.
Rapid traverse	1 335 mm/min
Z axis	
Cross table stroke	manual 400 mm / automatic 320 mm
Table feed	23 / 625 mm/min.
Rapid traverse	1 335 mm/min
Dimensions	
Length x width x height	1 760 x 1 550 x 1 700 mm
Weight	1 450 kg

Accessories	Article no.
Parallel shim set, 20-part	3354001
Horizontal-vertical rotary indexing table RT 150	3356150
Horizontal-vertical rotary indexing table RT 200	3356200
Horizontal-vertical rotary indexing table RTE 165	3356365
Horizontal-vertical rotary indexing table RTU 165	3354165
Assortment of clamping tools size 12, 58 parts	3352017
Blank holder set of 2 14 mm/M12	3352031
End mill set HSS 12-part	3352250
End mill set HSS 20-part	3352255
Precision machine shoe SEU1 (4 pcs. required) see page 128	3352985
Arbor for drill chuck ISO 40/B16	3352070
Collet chuck set 18-part ISO40	3352056

> More accessories for milling machines from page 122

** Important information on transport surcharge and „Operation of machines with frequency converters“ on page 249
The milling machines (frequency inverters) comply with standard DIN EN 55011:2011-04 class C2

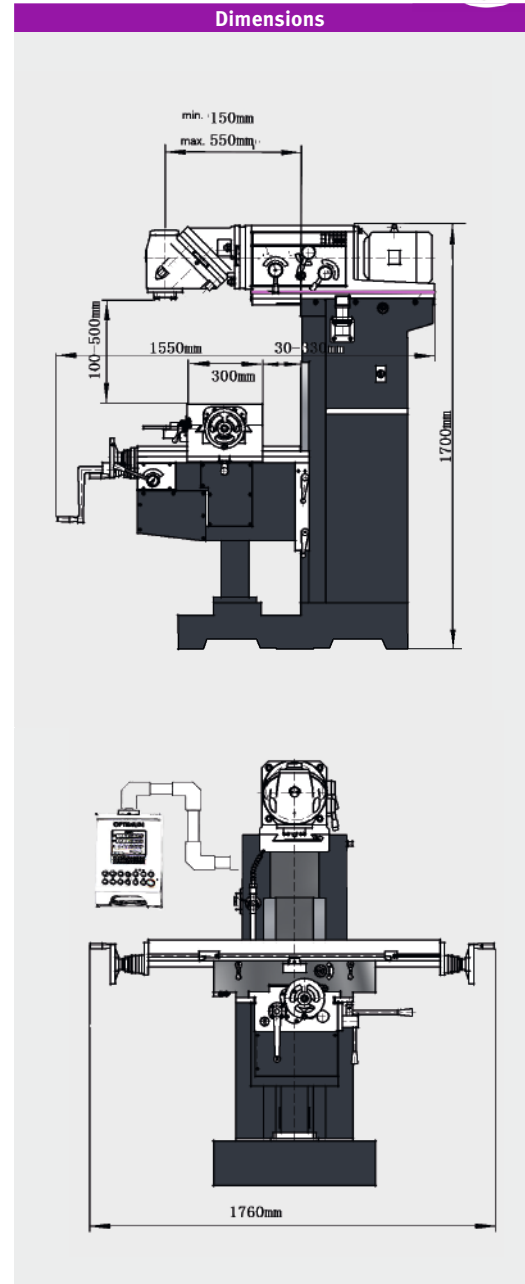

Scope of supply

- > ISO 40 taper shank with arrester for horizontal milling
- > Cutter arbour Ø 32 mm
- > Operating tool

Machine vices

Machine vices	Article no.
HMS 125	3355127
FMS 150	3354150
FMSN 150	3354130
VMQ 150	3354183
MV3-75	3354175
MV3-125	3354178
DAS 100	3355500
HCV 105	3356210

> Information about vices from page 116

Preface

Drilling

Milling

Turning

Saws

Grinding

Polishing

Lamps

Measuring

Versatile and easy retooling.

The universal milling machine for workshops

Facts that impress in terms of quality, performance and price

- ▶ Versatile range of applications
- ▶ Heavy, solid design using premium cast meehanite
- ▶ Vertical and horizontal milling position
- ▶ Rugged machine construction
- ▶ Milling head pivots and rotates to any spatial angle
- ▶ Smooth action due to polished gearwheels running in an oil sump
- ▶ All guides tempered and adjustable using cleats
- ▶ Central lubrication
- ▶ Generously dimensioned, decoupled hand wheels with scales
- ▶ LED machine lamp
- ▶ Coolant system
- ▶ Easy operation of the switching elements
- ▶ Sturdy, square guide rails on Y and Z axis
- ▶ Height-adjustable protective screen with microswitch for best possible user protection against chips and parts being flung out
- ▶ Solid and generously dimensioned cross table with precision surface finish and T-slots
- ▶ Digital position display DPA 2000
- ▶ Feed motor with fixed speeds
- ▶ Table feed X and Y axis
- ▶ Z axis with electrical table height adjustment

OPTI Control panel

- › Integrated switch panel
- › Integrated **digital position display**
- › Rotates about its own axis

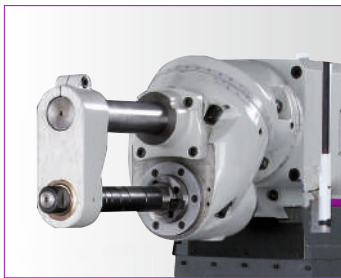

Horizontal milling position

- › with arrester and collet for disc milling cutter
- › Adjustable plain bearing

Vertical milling position

- › E.g., for milling V-ledges along the X axis



Fig.: MT 100

Technical specifications, accessories and dimensions



Model	MT 100
Article no.	3336110
Technical data	
Electrical connection	400 V / 3 Ph ~50 Hz
Total rated value	3.36 kW
Drive motor	2.2 kW
Feed motor output X-Y axis	370 Watts
Feed motor output Z-axis	750 Watts
Coolant pump motor	40 Watts
Drilling/milling output	
Max. sensor head size	Ø 85 mm
Max. shaft milling cutter size	Ø 20 mm
Vertical	
Spindle seat	ISO 40 DIN 2080
Draw-in rod	M16
Clearance spindle to cross table	90 - 520 mm
Spindle speeds	45 - 1 600 rpm
Speeds	11 speeds
Milling head tilt angle	360°
Cross table	
Length x width	1 120 x 260 mm
Max. load bearing capacity	350 kg
T-slot size / spacing / count	14 mm / 63 mm / 3
X axis	
Travel	manual 600 mm/automatic 480 mm
Manual table feed	24 - 402 mm/min.
Y axis	
Cross table stroke	manual 270 mm/ automatic 215 mm
Table feed automatic	24 - 402 mm/min.
Z axis	
Travel	manual 380 mm
Table feed automatic	402 mm/min
Dimensions	
Length x width x height	1 540 x 1 355 x 1 650 mm
Weight	1 300 kg

Accessories	Article no.
Parallel shim set, 20-part	3354001
Horizontal-vertical rotary indexing table RT 150	3356150
Horizontal-vertical rotary indexing table RT 200	3356200
Horizontal-vertical rotary indexing table RTE 165	3356365
Horizontal-vertical rotary indexing table RTU 165	3354165
Universal dividing head TA 125	3356125
End mill set HSS 12-part	3352250
End mill set HSS 20-part	3352255
Assortment of clamping tools size 12, 58 parts	3352017
Blank holder set of 2 14 mm/M12	3352031
Precision machine shoe SEU1 (4 pcs. required) see page 128	3352985
Arbor for drill chuck ISO 40/B16	3352070
Collet chuck set 18-part ISO40	3352056
Precision bore head set ISO 40	3352128
Copying and facing blade head ISO 40 DIN 2080	3350216
› More accessories for milling machines from page 122	

* Important information on transport surcharge and lump sum see page 251

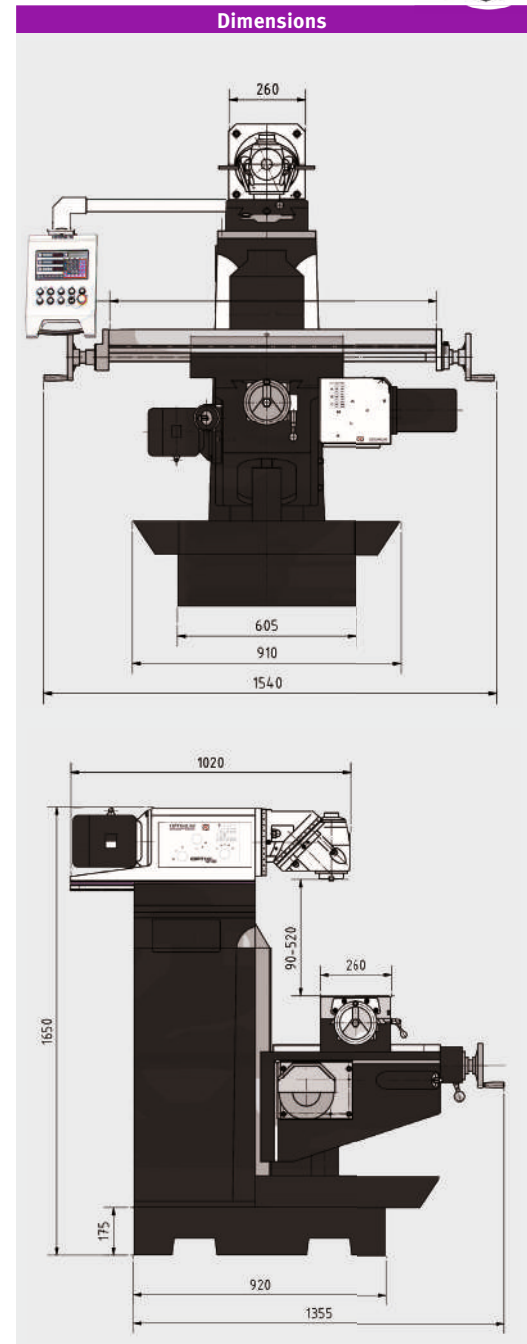

Scope of supply

- › Cutter spindle horizontal milling Ø 32 mm
- › Cutter arbour Ø 32 mm
- › Operating tool

Machine vices	Article no.
HMS 125	3355127
FMS 150	3354150
FMSN 150	3354130
VMQ 150	3354183
MV3-75	3354175
MV3-125	3354178
DAS 100	3355500
HCV 105	3536210
› Information about vices from page 116	

Multifunctional drilling/milling machines for professional deployment. Electronic continuously variable drive with frequency inverter "made in EU" and digital 3-axis position display DPA 21

Facts that impress in terms of quality, performance and price

- ▶ Heavy, solid design using premium cast meehanite
- ▶ Tilting drilling/milling head ± 45°
- ▶ Excellent concentricity thanks to tapered roller bearings, better than 0.01 mm measured in the spindle sleeve
- ▶ Automatic spindle sleeve feed
- ▶ Adjustable drilling depth stop with millimetre scale, can be read off on front
- ▶ Right-handed/left-handed rotation for thread tapping
- ▶ X and Z axis with adjustable dovetail guide
- ▶ Coolant system
- ▶ Height-adjustable protective screen with microswitch for best possible user protection against chips and parts being flung out

- ▶ Solid and generously dimensioned cross table with precision surface finish and T-slots

MF 2V:

- ▶ Y axis with adjustable dovetail guide

MF 4V:

- ▶ Y axis with flat guide
- ▶ Large Y axis stroke of 400 mm
- ▶ Motorised table height adjustment (Z axis)

**Siemens inverter
SINAMICS G110M**

- > Especially EMC compatible due to compact design
- > Internal safety function



Made in EU

**Optional tool clamping system
(Article no.: 3352394)**

OPTi Control panel

- Integrated switch panel
- > Integrated **digital position display DPA 21** with speed display

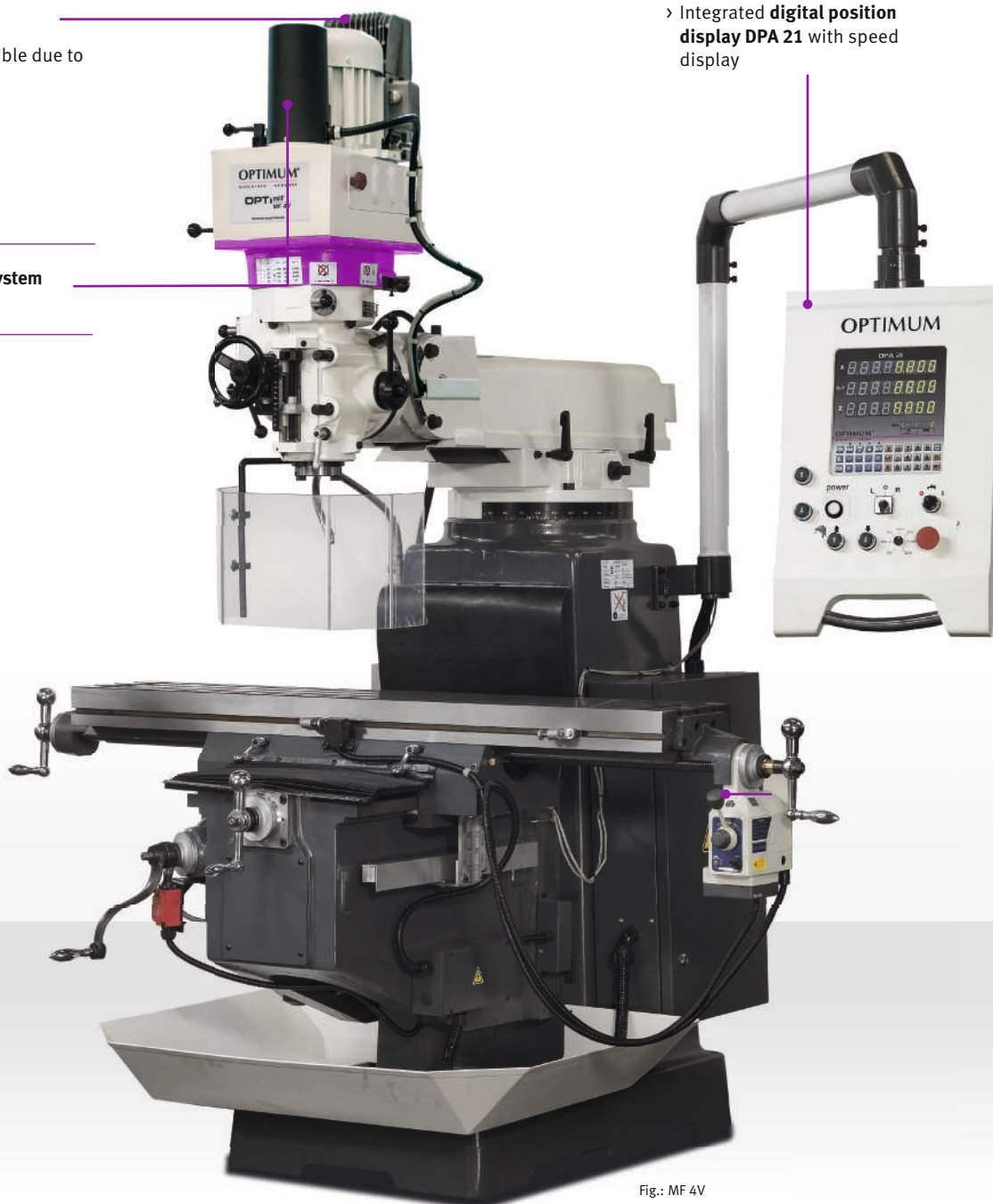
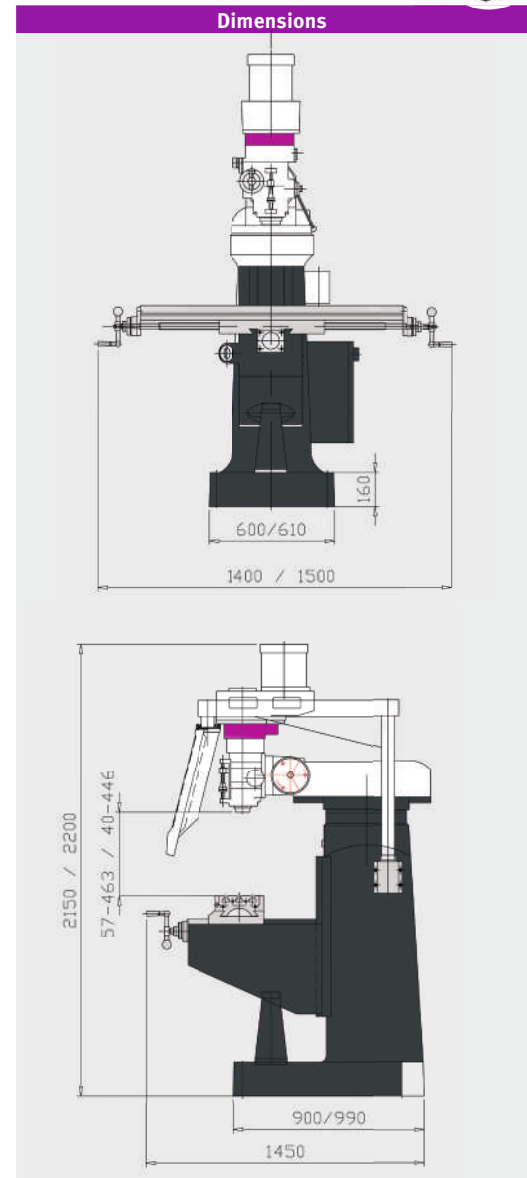

Fig.: MF 4V



Technical specifications, accessories and dimensions

Model	MF 2V	MF 4V
Article no.	3336030	3336050
Technical data		
Electrical connection	400 V / 3 Ph ~50 Hz	
Total rated value	2.2 kW	4 kW
Drive motor	1.5 kW	3 kW
Coolant pump motor	100 Watts	
Drilling/milling output		
Drilling performance in steel (S235JR)	Ø 24 mm	Ø 32 mm
Continuous drilling performance in steel (S235JR)	Ø 20 mm	Ø 28 mm
Max. sensor head size	Ø 76 mm	Ø 100 mm
Max. shaft milling cutter size	Ø 18 mm	Ø 20 mm
Spindle		
Spindle sleeve stroke	127 mm	
Spindle seat	ISO 40 DIN 2080	
Throat	213 - 533 mm	200 - 680 mm
Drilling/milling head		
Spindle speeds	10 - 5 100 rpm	9 - 6 750 rpm
Speeds	6 speeds, electronically controlled	8 speeds, electronically controlled
Pivoting spindle head	± 45°	
Automatic spindle sleeve feed	3 speeds: 0.038 / 0.076 / 0.152 mm/rev	
Cross table		
Length x width	1 245 x 230 mm	1 370 x 254 mm
Max. load bearing capacity	230 kg	275 kg
T-slot size / spacing / count	16 mm / 63 mm / 3	
Clearance spindle to cross table	57 - 463 mm	40 - 446 mm
Travel		
X axis	manual 800 mm / automatic 730 mm	manual 930 mm / automatic 850 mm
Y axis	manual 305 mm	manual 400 mm
Z axis	manual 406 mm	manual 406 mm / automatic 350 mm
Dimensions		
Length x width x height	1 400 x 1 450 x 2 150 mm	1 500 x 1 450 x 2 200 mm
Weight	950 kg	1 150 kg



Accessories	Article no.
Parallel shim set, 20-part	3354001
Horizontal-vertical rotary indexing table RT 150	3356150
Horizontal-vertical rotary indexing table RT 200	3356200
Horizontal-vertical rotary indexing table RTE 165	3356365
Horizontal-vertical rotary indexing table RTU 165	3354165
Assortment of clamping tools size 14, 58-parts	3352018
End mill set HSS TiN-coated 12-part	3352250
End mill set HSS TiN-coated 20-part	3352255
Precision machine shoe SEU1 (4 pcs. required) see page 128	3352985
Levelling platen SE 85 (4 pcs. required)	3352982
Arbor for drill chuck ISO 40/B16	3352070
Collet chuck set 18-part ISO40	3352056
Copying and facing blade head ISO 40 DIN 2080	3350216
Precision bore head set ISO 40	3352128
Universal table feed V 250	3352025
Assembly table feed V250	9000489
Tool clamping system ISO 40	3352394
(Orders without assembly: Some adjustment work may be necessary.)	
› More accessories for milling machines from page 122	

Scope of supply
› Chip tray
› Operating tool

Machine vices	Article no.
ZAS 50	3354170
HMS 125	3355127
FMS 125	3354125
FMS 150	3354150
FMSN 125	3354120
FMSN 150	3354130
VMQ 125	3354182
VMQ 150	3354183
MV3-75	3354175
MV3-125	3354178
DAS 100	3355500
HCV 105	3356210
Information about vices from page 116	

* Important information on transport surcharge and lump sum and „Operation of machines with frequency converters“ on page 249
The milling machines (frequency inverters) comply with standard DIN EN 55011:2011-04 class C2

Multifunctional drilling/milling machines with mechanised continuously controllable drive for professional use

Facts that impress in terms of quality, performance and price

- ▶ Solid design using premium cast meehanite
- ▶ Excellent concentricity thanks to tapered roller bearings, better than 0.01 mm measured in the spindle sleeve
- ▶ Continuously variable speed control
- ▶ Right-handed/left-handed rotation for thread tapping
- ▶ X and Y axis with adjustable 55 ° dovetail guide
- ▶ Y axis with flat guide
- ▶ Tilting drilling/milling head ± 45°
- ▶ Coolant system
- ▶ Clockwise/Anti-clockwise run
- ▶ Automatic spindle sleeve feed, 3 stages, 0.04 - 0.15 mm/rev
- ▶ Motorised feed on X, Y and Z axes
- ▶ Precision micro feed
- ▶ Milling spindle with precision bearing

- ▶ Mechanical spindle brake
- ▶ Drilling depth scale and stop
- ▶ Cross table with T-slots and coolant channel
- ▶ Central lubrication
- ▶ Height-adjustable protective screen with microswitch for best possible user protection against chips and parts being flung out
- ▶ Solid and generously dimensioned cross table with precision surface finish and T-slots

MF 4-B:

- ▶ Cross table load bearing capacity 300 kg
- ▶ Long travel: X / Y / Z axis
- ▶ 740 mm / 330 mm / 320 mm



Control panel

- > Integrated switch panel
- > Integrated **digital position display DPA 2000** with speed display

Fig.: MF 4-B

Technical specifications, accessories and dimensions

Model	MF 2-B	MF 4-B
Article no.	3348330	3348340
Technical specifications		
Electrical connection	400 V / 3 Ph ~50 Hz	
Total rated value	3 kW	
Drive motor	2.2 kW	
Coolant pump motor	90 W	
Drilling/milling output		
Drilling performance in steel (S235JR)	Ø 24 mm	
Continuous drilling performance in steel (S235JR)	Ø 20 mm	
Max. sensor head size	Ø 76 mm	
Max. shaft milling cutter size	Ø 25 mm	
Spindle		
Spindle sleeve diameter	86 mm	
Spindle sleeve stroke	127 mm	
Spindle seat	ISO 40 DIN 2080	
Throat	15 - 415 mm	0 - 420 mm
Drilling/milling head		
Spindle speeds	60 - 4 200 rpm	
Speeds	2 speed, mechanically continuously controllable	
Milling cutter head travel	312 mm	470 mm
Swivel range spindle head horizontal	± 90°	
Swivel range spindle head vertical	± 45°	
Automatic spindle sleeve feed	3 speeds: 0.038 / 0.076 / 0.152 mm/rev	
Cross table		
Length x width	230 x 1 246 mm	254 x 1 370 mm
Cross table max. load bearing capacity	200 kg	300 kg
T-slot size / spacing / count	16 mm / 63 mm / 3	
Clearance spindle to cross table	405 mm	
Travel		
X axis	manual 690 mm / automatic 610 mm	manual 820 mm / automatic 740 mm
Y axis	manual 310 mm / automatic 230 mm	manual 410 mm / automatic 330 mm
Z axis	manual 390 mm / automatic 310 mm	manual 400 mm / automatic 320 mm
Dimensions		
Length x width x height	2 000 x 1 600 x 2 010 mm	2 400 x 2 160 x 2 300 mm
Weight	1 000 kg	1 260 kg

Accessories	Article no.
Parallel shim set, 20-part	3354001
Horizontal-vertical rotary indexing table RT 150	3356150
Horizontal-vertical rotary indexing table RT 200	3356200
Horizontal-vertical rotary indexing table RTE 165	3356365
Horizontal-vertical rotary indexing table RTU 165	3354165
Assortment of clamping tools size 14, 58-parts	3352018
End mill set HSS TiN-coated 12-part	3352250
End mill set HSS TiN-coated 20-part	3352255
Precision machine shoe SEU1 (4 pcs. required) see page 128	3352985
Levelling platen SE 85 (4 pcs. required)	3352982
Arbor for drill chuck ISO 40/B16	3352070
Collet chuck set 18-part ISO40	3352056
Copying and facing blade head ISO 40 DIN 2080	3350216
Precision bore head set ISO 40	3352128
› More accessories for milling machines from page 122	

* Important information on transport surcharge and lump sum see page 251

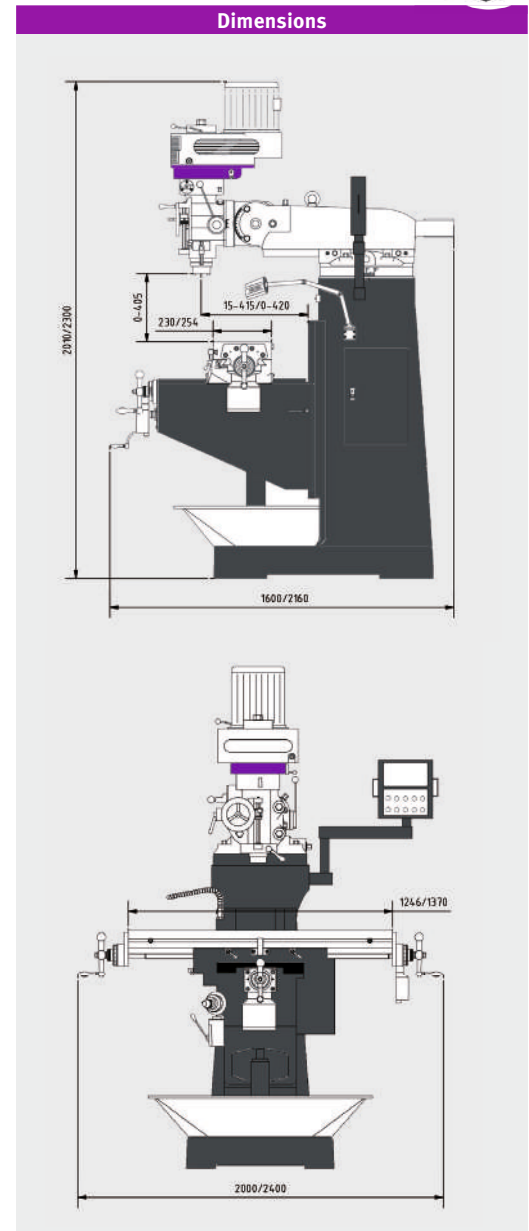

Scope of supply

› Operating tool

Machine vices	Article no.
ZAS 50	3354170
HMS 125	3355127
FMS 125	3354125
FMS 150	3354150
FMSN 125	3354120
FMSN 150	3354130
VMQ 125	3354182
VMQ 150	3354183
MV3-75	3354175
MV3-125	3354178
DAS 100	3355500
HCV 105	3536210
› Information about vices from page 116	



Preface

Drilling

Milling

Turning

Saws

Grinding

Polishing

Lamps

Measuring

Universal milling machine for horizontal and vertical milling work.

With digital 3-axis position display DPA 21

Facts that impress in terms of quality, performance and price

- ▶ Tilting drilling/milling head $\pm 90^\circ$
- ▶ Spindle head carrier moves to front and rear
- ▶ Heavy, solid design using premium vibration-absorbing grey cast material
- ▶ Counterholder for horizontal milling attached to rear for easy access
- ▶ Spindle sleeve feed via spindle sleeve lever or manual fine feed hand wheel
- ▶ X axis can be moved optionally with the hand wheel or the table feed unit
- ▶ Coolant system
- ▶ Automatic spindle sleeve feed
- ▶ Height-adjustable protective screen with microswitch for best possible user protection against chips and parts being flung out
- ▶ Solid and generously dimensioned cross table with precision surface finish including adjustable cleats, tilting $\pm 45^\circ$



Horizontal milling position

- › For work in horizontal milling position with arrester and collet for disc milling cutter

Digital position display DPA 21

- › Clear-cut keyboard layout
- › Dazzle-free display
- › Resolution $5 \mu\text{m}$
- › Accuracy $\pm 0.003 \text{ mm}$
- › Protected against dust, chips and splash water by a rubber lip



Fig.: MT 60

Technical specifications, accessories and dimensions



Model	MT 60
Article no.	3336090
Technical data	
Electrical connection	400 V / 3 Ph ~50 Hz
Total rated value	5 kW
Horizontal and vertical drive motor	2.2 kW
Coolant pump motor	40 W
Drilling/milling output	
Drilling performance in steel (S235JR)	Ø 30 mm
Continuous drilling performance in steel (S235JR)	Ø 25 mm
Max. sensor head size	Ø 100 mm
Max. shaft milling cutter size	Ø 25 mm
Spindle	
Spindle seat	ISO 40 DIN 2080
Vertical	
Spindle sleeve stroke	120 mm
Clearance spindle to cross table	60 - 420 mm
Spindle sleeve diameter	Ø 90 mm
Draw-in rod	M16
Spindle speeds	90 - 2 000 rpm
Speeds	8 speeds
Throat	200 - 550 mm
Automatic spindle sleeve feed	3 speeds: 0.08 / 0.25 / 1 mm/rev
Horizontal	
Throat	35 - 370 mm
Spindle speeds	40 - 1 300 rpm
Speeds	9 speeds
Cross table	
Length x width	1 270 x 280 mm
Cross table max. load bearing capacity	150 kg
T-slot size / spacing / count	14 mm / 50 mm / 4
Travel	
X axis manual / automatic	750 mm / 680 mm
Y axis manual	230 mm
Z axis manual	360 mm
Dimensions	
Length x width x height	1 580 x 1 450 x 2 100 mm
Weight	1 300 kg

Accessories	Article no.
Parallel shim set, 20-part	3354001
Horizontal-vertical rotary indexing table RT 150	3356150
Horizontal-vertical rotary indexing table RT 200	3356200
Horizontal-vertical rotary indexing table RTE 165	3356365
Horizontal-vertical rotary indexing table RTU 165	3354165
Assortment of clamping tools size 12, 58-parts	3352017
End mill set HSS TiN-coated 12-part	3352250
End mill set HSS TiN-coated 20-part	3352255
Workpiece support WPS-4	3354264
Precision machine shoe SEU1 (4 pcs. required) see page 128	3352985
Levelling platen SE 85 (4 pcs. required)	3352982
Arbor for drill chuck ISO 40/M16/B16	3352070
Collet chuck set 18-part ISO40	3352056
Hold-down unit set of 2	3352031
Copying and facing blade head ISO 40 DIN 2080	3350216
Precision bore head set ISO 40	3352128
› More accessories for milling machines from page 122	

* Important information on transport surcharge and lump sum see page 251

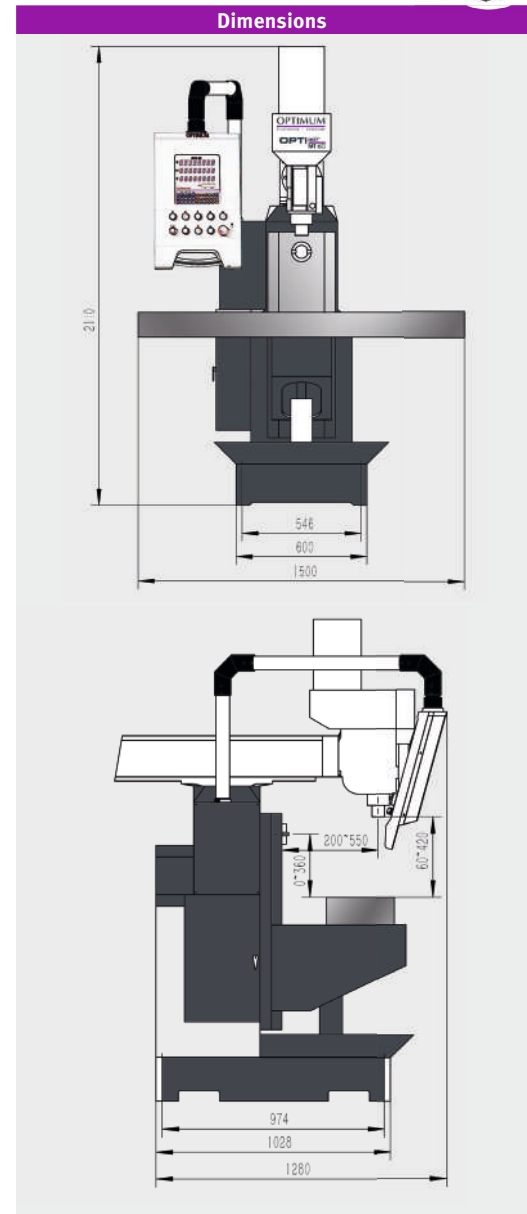

Scope of supply
› Key type drill chuck Ø 1 - 16 mm / B16
› Arbor for drill chuck ISO40 / B16
› Adapter ISO 40 / MT 3
› Adapter ISO 40 / MT 2
› Cutter spindle horizontal milling Ø 22 mm
› Cutter spindle horizontal milling Ø 27 mm
› Milling chuck Ø 4 - Ø 16 mm
› Tie rod vertical and horizontal
› Operating tool

Machine vices	Article no.
FMS 125	3354125
FMSN 125	3354120
VMQ 100	3354181
MV3-75	3354175
MV3-125	3354178
DAS 100	3355500
ZAS 50	3354170
› Information about vices from page 116	

Preface

Drilling

Milling

Turning

Saws

Grinding

Polishing

Lamps

Measuring

Universal milling machine for horizontal and vertical milling work with digital 3-axis position display DPA 2000

Facts that impress in terms of quality, performance and price

- ▶ Heavy, solid design using premium vibration-absorbing grey cast material
- ▶ Halogen machine lamp with tight beam
- ▶ Spindle sleeve feed via spindle sleeve lever or manual fine feed hand wheel
- ▶ Counterholder for horizontal milling attached to rear for easy access
- ▶ Automatic end position cut-off on X axis
- ▶ X axis can be moved optionally with the hand wheel or the table feed unit
- ▶ Spindle head carrier pivots through 90° left and right
- ▶ Gears in oil bath with polished, hardened gear wheels
- ▶ Right-handed/left-handed rotation
- ▶ Coolant system
- ▶ Precision Cross table, generously dimensioned with precision surface finish
- ▶ Cross table turns through 45° on both sides



Horizontal milling position

- › For work in horizontal milling position with arvester and collet for disc milling cutter



Control panel

- › Pivots to left and right side of machine



Cross table housing

- › Fold-up type
- › Removable
- › Swivelling



Fig.: OPTImill MT 50

Technical specifications, accessories and dimensions

Model	MT 50
Article no.	3336005
Technical data	
Electrical connection	400 V / 3 Ph ~50 Hz
Total rated value	4.5 kW
Vertical drive motor	1.1 / 2.2 kW
Horizontal drive motor	1.5 kW
Coolant pump motor	40 W
Drilling/milling output	
Drilling performance in steel (S235JR)	Ø 30 mm
Continuous drilling performance in steel (S235JR)	Ø 25 mm
Max. sensor head size	Ø 100 mm
Max. shaft milling cutter size	Ø 25 mm
Spindle	
Spindle seat	ISO 40 DIN 2080
Vertical	
Spindle sleeve stroke	120 mm
Spindle speeds	115 - 1 750 rpm
Speeds	8 speeds
Throat	240 - 650 mm
Horizontal	
Spindle speeds	60 - 1 350 rpm
Speeds	9 speeds
Throat	0 - 185 mm
Cross table	
Length x width	1 000 x 240 mm
Cross table max. load bearing capacity	160 kg
T-slot size / quantity	14 mm / 4
Rotating Cross table	± 45°
Travel	
X axis	manual 580 mm / automatic 500 mm
Table feed X axis (8 speeds)	24 / 720 mm/min.
Y axis manual	200 mm
Z axis manual	340 mm
Dimensions	
Length x width x height	2 270 x 1 500 x 2 080 mm
Weight	820 kg

Accessories	Article no.
Parallel shim set, 20-part	3354001
Horizontal-vertical rotary indexing table RT 150	3356150
Horizontal-vertical rotary indexing table RT 200	3356200
Horizontal-vertical rotary indexing table RTE 165	3356365
Horizontal-vertical rotary indexing table RTU 165	3354165
Assortment of clamping tools size 12, 58 parts	3352017
End mill set HSS TiN-coated 12-part	3352250
End mill set HSS TiN-coated 20-part	3352255
Workpiece support WPS-4	3354264
Precision machine shoe SEU1 (4 pcs. required) see page 128	3352985
Levelling platen SE 85 (4 pcs. required)	3352982
Arbor for drill chuck ISO 40/B16	3352070
Collet chuck set 18-part ISO40	3352056
Copying and facing blade head ISO 40 DIN 2080	3350216
Precision bore head set ISO 40	3352128
Hold-down unit set of 2	3352031
› More accessories for milling machines from page 122	

* Important information on transport surcharge and lump sum see page 251

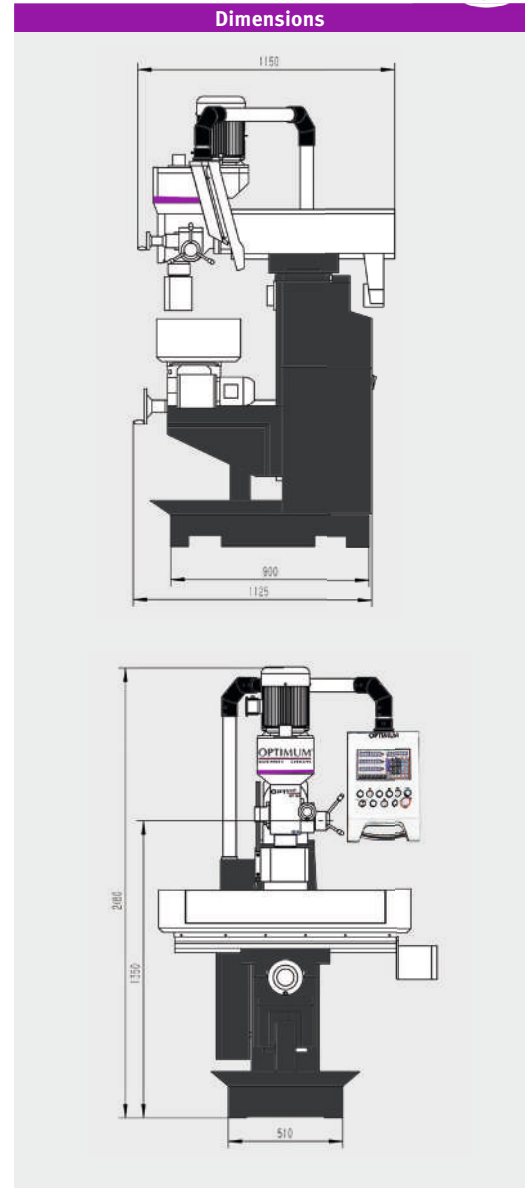

Scope of supply
› Key type drill chuck 1 - 16 mm / B18
› Arbor for drill chuck ISO40 / B18
› Cutter spindle horizontal milling Ø 22 / Ø 27 mm
› Reduction sleeve ISO 40-MT 3 / ISO 40-MT 2
› Tie rod vertical and horizontal
› T-slot nuts
› Push-out tool
› Operating tool

Machine vices	Article no.
FMS 125	3354125
FMSN 125	3354120
VMQ 100	3354181
MV3-75	3354175
MV3-125	3354178
DAS 100	3355500
ZAS 50	3354170
› Information about vices from page 116	

Universal drilling/milling machine with automatic table feed for X and Y axis

Facts that impress in terms of quality, performance and price

- ▶ Vibration absorbing cast design
- ▶ Operation-friendly control panel
- ▶ LED lamp
- ▶ Milling head pivots through 45° to left and right
- ▶ Automatic feed of X and Y axis with speed adjustment
- ▶ Automatic and adjustable limit switch cut-off of the X axis
- ▶ Mechanical spindle sleeve feed for drilling via spindle sleeve lever
- ▶ Gears in oil bath with polished, hardened gear wheels
- ▶ Right-handed/left-handed rotation
- ▶ Coupling for switching from manual coarse feed to manual fine feed
- ▶ Large Y axis spindle head holder throat of 250 - 650 mm
- ▶ Precision Cross table, generously dimensioned with precision surface finish with adjustable V-ledges
- ▶ Height-adjustable protective screen with microswitch for best possible user protection against chips and parts being flung out
- ▶ Solid and generously dimensioned cross table with dovetails, precision surface finish including T-slots and adjustable cleats, tilting ± 45
- ▶ Coolant system

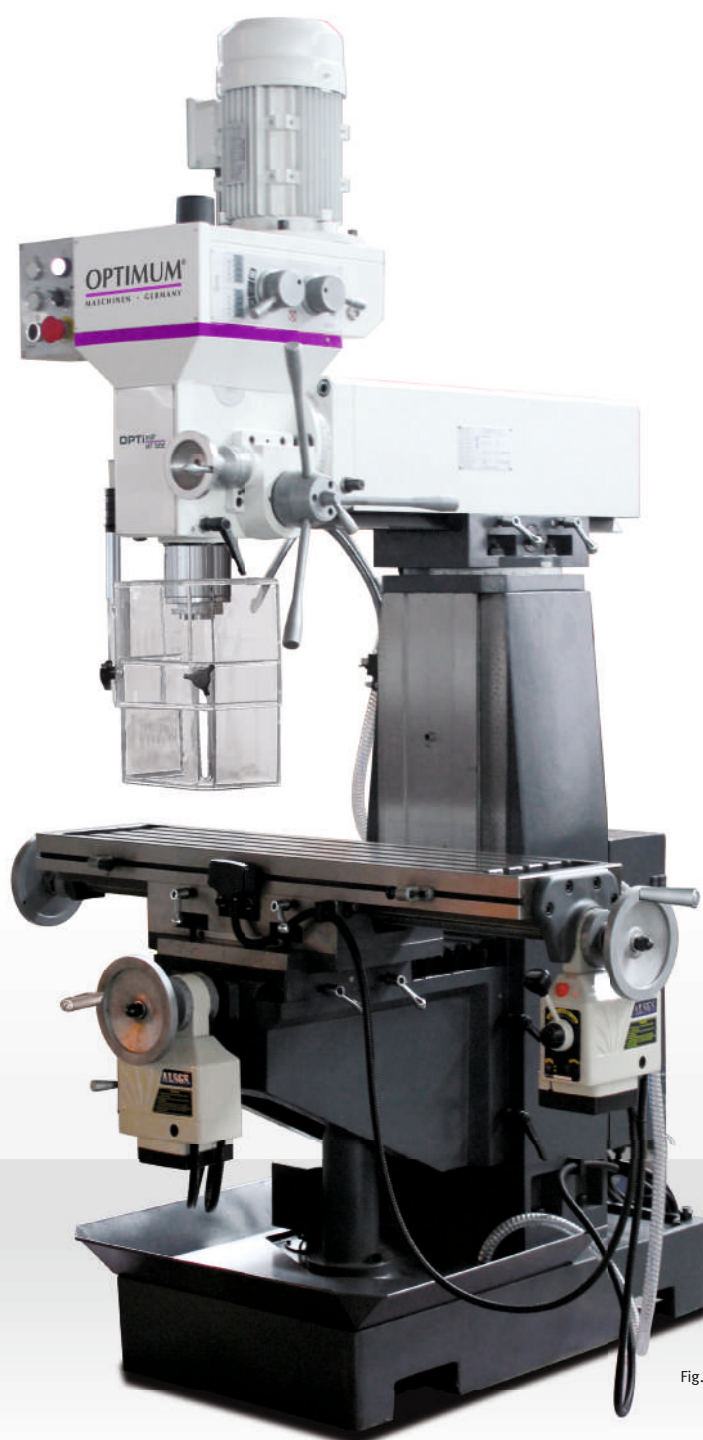

Fig.: MT 50E

Technical specifications, accessories and dimensions

Model	MT 50E
Article no.	3336010
Technical data	
Electrical connection	400 V / 3 Ph ~ 50 Hz
Drive motor	0.85 / 1.5 kW
Coolant pump motor	40 W
Drilling performance	
Drilling performance in steel (S235JR)	Ø 30 mm
Continuous drilling performance in steel (S235JR)	Ø 25 mm
Max. sensor head size	Ø 63 mm
Max. shaft milling cutter size	Ø 25 mm
Spindle	
Spindle seat	SK40 DIN 2080
Spindle sleeve stroke	120 mm
Draw-in rod	M16
Distance spindle to cross table	60 - 360 mm
Drilling/milling head	
Spindle speeds	115 - 1 750 rpm
Gears / motor speeds	4-speed / 2-speed
Milling head tilt	± 45°
Throat	250 - 650 mm
Cross table	
Length x width	1 000 x 240 mm
Cross table max. load bearing capacity	150 kg
T-slot size / quantity	14 mm / 4
Swivel range	± 45°
Travel	
X axis	manual 580 mm / automatic 500 mm
Y axis	manual 230 mm / automatic 150 mm
Z axis manual	400 mm
Dimensions	
Length x width x height	1 360 x 1 150 x 2 080 mm
Weight	760 kg

Accessories	Article no.
Parallel shim set, 20-part	3354001
Horizontal-vertical rotary indexing table RT 150	3356150
Horizontal-vertical rotary indexing table RT 200	3356200
Horizontal-vertical rotary indexing table RTE 165	3356365
Horizontal-vertical rotary indexing table RTU 165	3354165
Assortment of clamping tools size 12, 58 parts	3352017
End mill set HSS TiN-coated 12-part	3352250
End mill set HSS TiN-coated 20-part	3352255
Workpiece support WPS-4	3354264
Precision machine shoe SEU1 (4 pcs. required) see page 128	3352985
Levelling platen SE 85 (4 pcs. required)	3352982
Arbor for drill chuck ISO 40/B16	3352070
Collet chuck set 18-part ISO40	3352056
Copying and facing blade head ISO 40 DIN 2080	3350216
Precision bore head set ISO 40	3352128
Hold-down unit set of 2	3352031

> **More accessories for milling machines** from page 122

* Important information on transport surcharge and lump sum see page 251

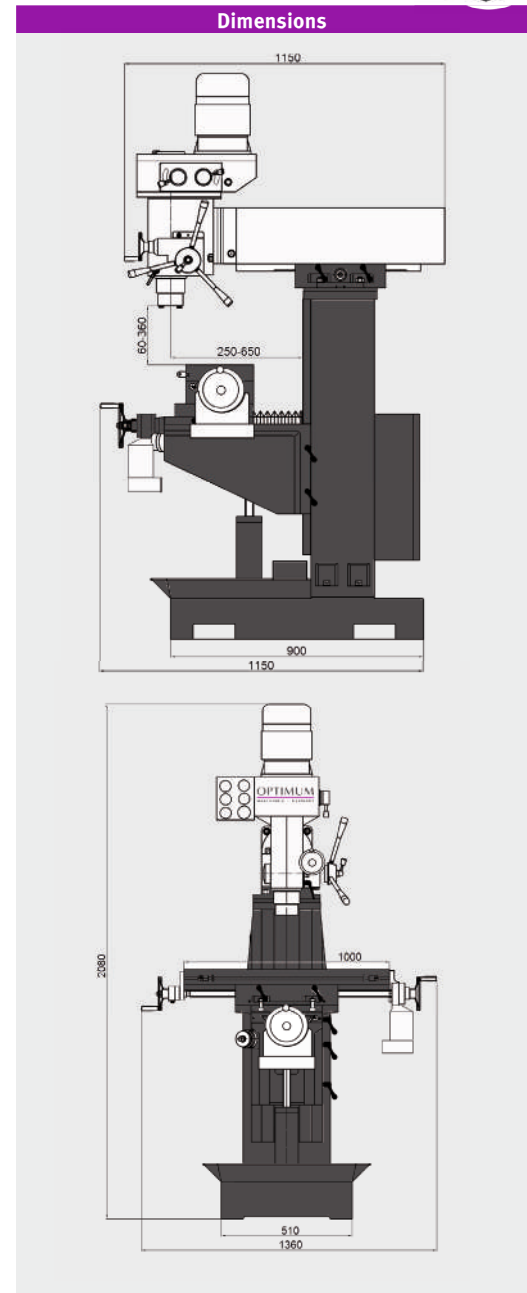

Scope of supply

- > Key type drill chuck 3 - 16 mm / B18
- > Arbor for drill chuck ISO40 / B18
- > T-slot nuts
- > Push-out tool
- > Reduction sleeve ISO40- MT 3/MT 3-MT 2
- > Operating tool

Machine vices	Article no.
FMS 125	3354125
FMSN 125	3354120
VMQ 100	3354181
MV3-75	3354175
DAS 100	3355500
ZAS 50	3354170

> Information about vices from page 116

Preface

Drilling

Milling

Turning

Saws

Grinding

Polishing

Lamps

Measuring

Universal drilling/milling machine with digital position display DRO 5 and cast machine chassis. MB 4PV with continuously variable electronically controlled drive

Facts that impress in terms of quality, performance and price

- ▶ Heavy, solid cast design
- ▶ Smooth action due to polished gearwheels running in an oil sump
- ▶ Right-handed/left-handed rotation
- ▶ Automatic spindle sleeve feed with manual fine feed
- ▶ Motorised positioning of the Z axis
- ▶ Motorised table feed on X axis
- ▶ Coolant system
- ▶ Machine lamp
- ▶ Gear head pivots through $\pm 60^\circ$
- ▶ Adjustable cleats
- ▶ Solid dovetail guide on column, hand honed for maximum stability and greatest possible precision
- ▶ Height-adjustable, large protective screen with micro switch
- ▶ Drilling depth stop
- ▶ Digital position display DRO 5
- ▶ Drilling/Thread tapping function
- ▶ Solid and generously dimensioned cross table with precision surface finish with T-slots and adjustable cleats
- ▶ Solid cast machine chassis with chip channel

MB 4P:

- ▶ Two-stage industrial quality electric motor
- ▶ Large speed range from 95 - 3 200 rpm thanks to 12 switchable speeds

MB 4PV:

- ▶ Single-speed, premium, industrial electric motor
- ▶ Large speed range from 60 - 2 760 rpm thanks to 2 continuously variable speeds

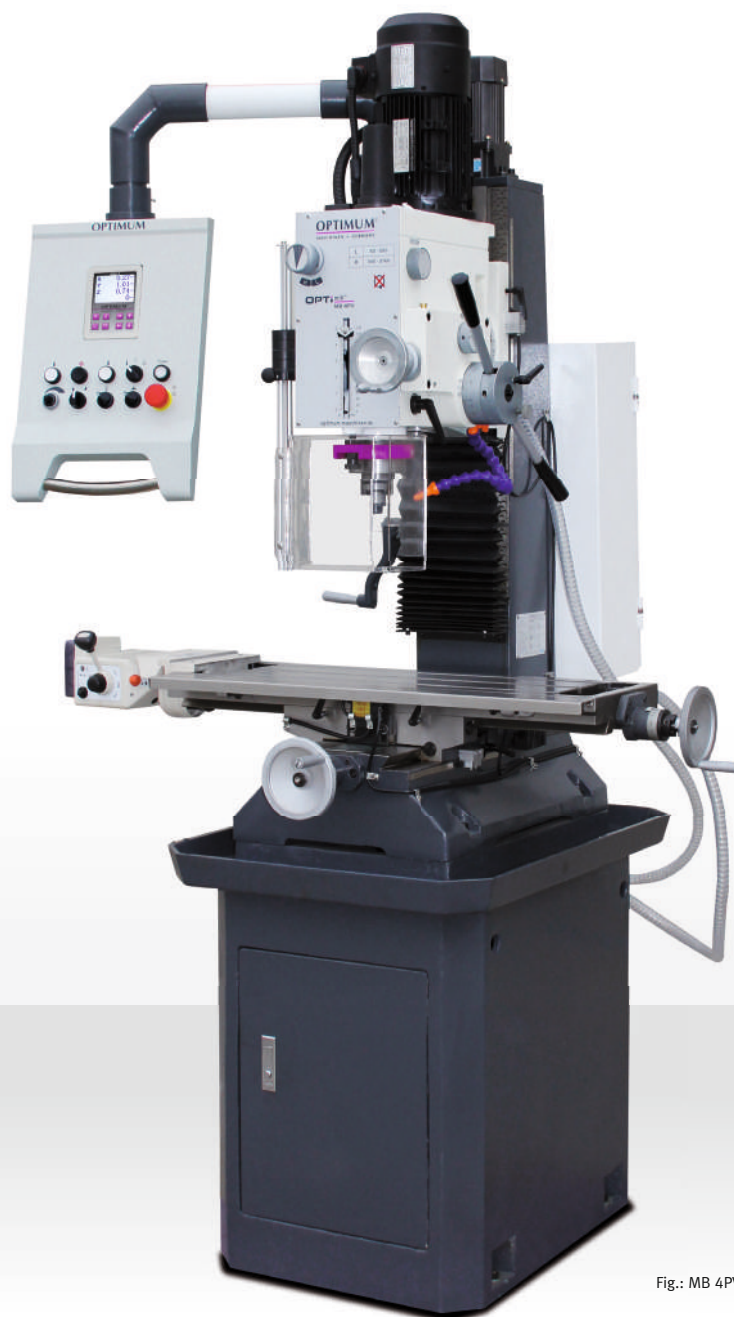

Fig.: MB 4PV

Technical specifications, accessories and dimensions

Model	MB 4P	MB 4PV***
Article no.	3338460	3338465
Technical data		
Electrical connection	400 V / 3 Ph ~50 Hz	230 V / 1 Ph ~50 Hz
Motor output	1.1 / 1.5 kW	1.5 kW
Coolant pump motor	100 W	
Drilling/milling output		
Drilling performance in steel (S235JR)	Ø 32 mm	Ø 24 mm
Continuous drilling performance in steel (S235JR)	Ø 28 mm	Ø 20 mm
Max. sensor head size	Ø 63 mm	Ø 63 mm
Max. shaft milling cutter size	Ø 28 mm	Ø 26 mm
Spindle		
Spindle sleeve stroke	120 mm	
Spindle seat	MT 4	
Spindle sleeve diameter	75 mm	
Throat	258 mm	
Draw-in rod	M16	
Drilling/milling head		
Spindle speeds	95 - 3 200 rpm	60 - 2 760 rpm
Speeds	2 x 6 speeds	2 speeds. electronically controlled
Pivot range	± 45°	± 45°
Cross table		
Clearance spindle to cross table max.	420 mm	
Length x width	800 x 240 mm	
T-slot size / spacing / count	14 mm / 80 mm / 3	
Automatic spindle sleeve feed	0.1 / 0.18 / 0.26 mm/rev	
Travel		
X axis	manual 560 mm / automatic 480 mm	
Y axis manual	195 mm	
Z axis manual	350 mm	
Dimensions		
Length x width x height	1 600 x 930 x 2 110 mm	
Weight	495 kg	

Scope of supply

- › Machine chassis
- › Morse taper MT 3/B16
- › Adapter MT 3 - MT 4
- › Draw-in rod M16
- › Operating tool

Accessories	Article no.
Parallel shim set, 20-part	3354001
Horizontal-vertical rotary indexing table RT 150	3356150
Horizontal-vertical rotary indexing table RTE 165	3356365
Height-adjustable tailstock RST 1	3356155
Height-adjustable tailstock RST 2	3356157
Assortment of clamping tools size 12, 58-parts	3352017
End mill set HSS TiN-coated 12-part	3352250
End mill set HSS TiN-coated 20-part	3352255
Copying and facing blade MT 4	3350214
Vibration dampers SE1 (4 pcs. required)	3381012
Bore head set MT 4	3352084
Arbor for drill chuck MK4	3350304
Collet chuck MT 4/M16	3352094
Thread tapping chuck M3 - M12	3050705
Thread tapping chuck M8 - M20	3050706
› More „Accessories for milling machines“ from page 126	

** Important information on transport surcharge and lump sum and „Operation of machines with frequency converters“ on page 249

***The milling machine complies with the DIN EN 55011 standard: class C2.

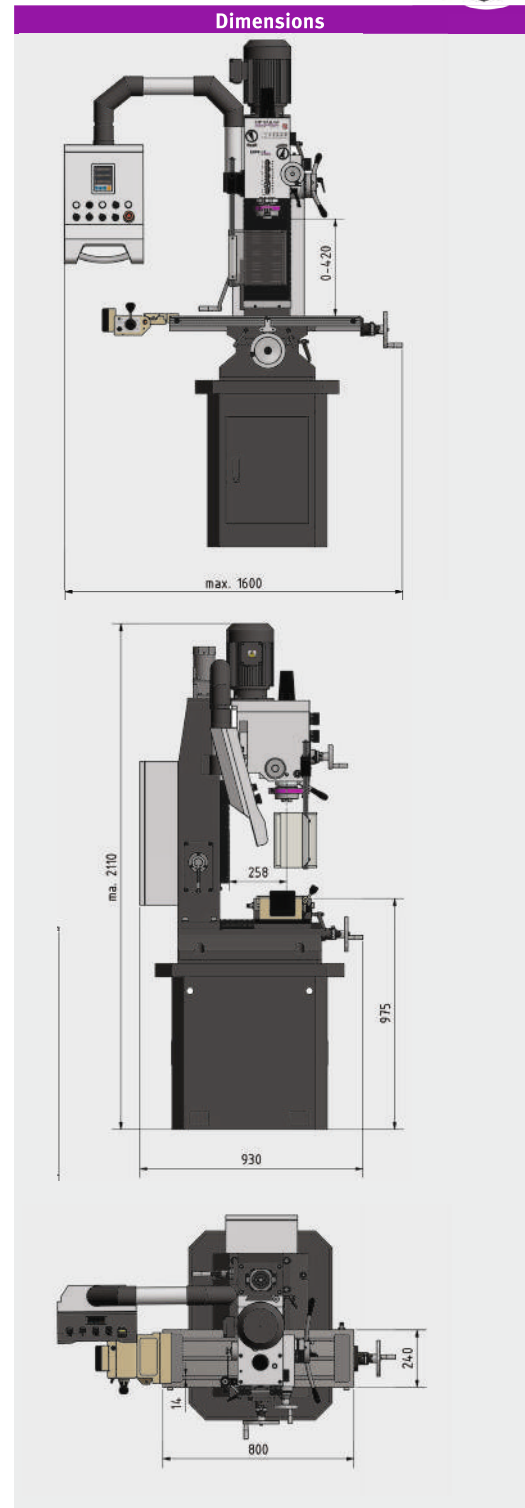

Machine vices	Article no.
FMS 100	3354100
FMS 125	3354125
HMS 100	3355100
FMSN 125	3354120
VMQ 100	3354181
MV3-75	3354175
DAS 100	3355500
ZAS 50	3354170
› Information about vices from page 116	

Preface

Drilling

Milling

Turning

Saws

Grinding

Polishing

Lamps

Measuring

Universal precision drilling/milling machines with manual gearbox and electrical Z axis adjustment. MH 50V with electronically controlled drive.

Control unit with dirt- and water-resistant membrane keyboard

Facts that impress in terms of quality, performance and price

- ▶ Control panel with user-friendly dirt and water resistant foil keyboard
- ▶ Easily readable digital display
- ▶ Easily readable spindle sleeve display in milling head
- ▶ Drilling depth stop
- ▶ Right-handed/left-handed rotation
- ▶ Thread tapping mode
- ▶ Rotary pushbutton on control panel for adjusting the drilling depth, optionally in mm or inches, with zero point
- ▶ Excellent concentricity thanks to tapered roller bearings, better than 0.015 mm measured in the spindle sleeve
- ▶ Gear head pivots through $\pm 30^\circ$
- ▶ Electrical milling head height adjustment
- ▶ Manual fine feed
- ▶ Adjustable cleats
- ▶ Height-adjustable protective screen with microswitch for best possible user protection against chips and parts being flung out
- ▶ Heavy, sturdy and solid columns made of premium cast material with ground and shaven dovetail guide for excellent stability and precision
- ▶ Z axis with slatted, stainless steel protective cover
- ▶ Solid and generously dimensioned cross table with precision surface finish and T-slots
- ▶ Optional, solid, heavy steel chassis ensures stability

MH 50G:

- ▶ Two-stage industrial quality electric motor

MH 50V:

- ▶ 6 speeds, electronically controlled



Energy chain

- › cable guidance easy on material



Mechanical

Quick change clamping system

- › The milling head is equipped with spring collet for pull stud BT40x45°
- › To change, simply release the mechanical lock on the quick-clamping system and push the spindle sleeve lever upwards



Fig.: MH 50V

Technical specifications, accessories and dimensions



Model	MH 50G	MH 50V***
Article no.	3338180	3338185
Technical data		
Electrical connection	400 V / 3 Ph ~ 50 Hz	
Motor output	1.5 / 2.2 kW	2.2 kW
Drilling/milling output		
Drilling performance in steel (S235JR)	Ø 38 mm	
Continuous drilling performance in steel (S235JR)	Ø 32 mm	
Max. sensor head size	Ø 80 mm	
Max. shaft milling cutter size	Ø 32 mm	
Spindle		
Spindle sleeve stroke	115 mm	
Spindle seat	BT 40	
Spindle sleeve diameter	80 mm	
Throat	260 mm	
Drilling/milling head		
Spindle speeds	225 - 3 260 rpm	50 - 3 260 rpm
Speeds	2 x 6 speeds	6 speeds electr. controlled
Pivot range	± 30°	
Cross table		
Length x width	850 mm x 240 mm	
T-Slot size / no / distance	18 mm / 3 / 80 mm	
Max. load bearing capacity	175 kg	
Clearance spindle to cross table	max. 545 mm	
Travel		
X axis manual	520 mm	
Y axis manual	260 mm	
Z axis	manual 465 mm / automatic 385 mm	
Dimensions		
Length x width x height max.	1 210 x 1 020 x 1 645 mm	
Weight	525 kg	

Accessories	Article no.
Milling head holder Ø 27 mm	3353336
Quick clamping drill chuck 1 - 13 mm	3536303
Weldon holder Ø 6 mm	3353340
Weldon holder Ø 8 mm	3353341
Weldon holder Ø 10 mm	3353342
Weldon holder Ø 12 mm	3353343
Weldon holder Ø 16 mm	3353344
Weldon holder Ø 20 mm	3353345
BT 40 - MT 3 adapter	3353335
Spring collet holder ER 32	3353334
Spring collet holder spanner ER 32	3353307
Collet kit ER 32	3441122
Height-adjuster	3536290
Assembly and tool adjustment gauge	3536193
Taper squeegee	3353331
Pull stud 40 x 45° M16	3353332
Pull stud DIN2080 M16	3536179
Universal table feed V99	3352022
Assembly kit V99 - X axis	3352036
Assortment of clamping tools size 16, 58-parts	3352019
Steel chassis (information on page 131)	3353015
Levelling platen SE 55 (4 pcs. required)	3352981
Vibration damping machine base SE1 (4 pcs. required)	3381012
› More accessories for milling machines from page 122	

** Important information on transport surcharge and „Operation of machines with frequency converters“ on page 249
***The milling machine complies with the DIN EN 55011 standard: class C2.

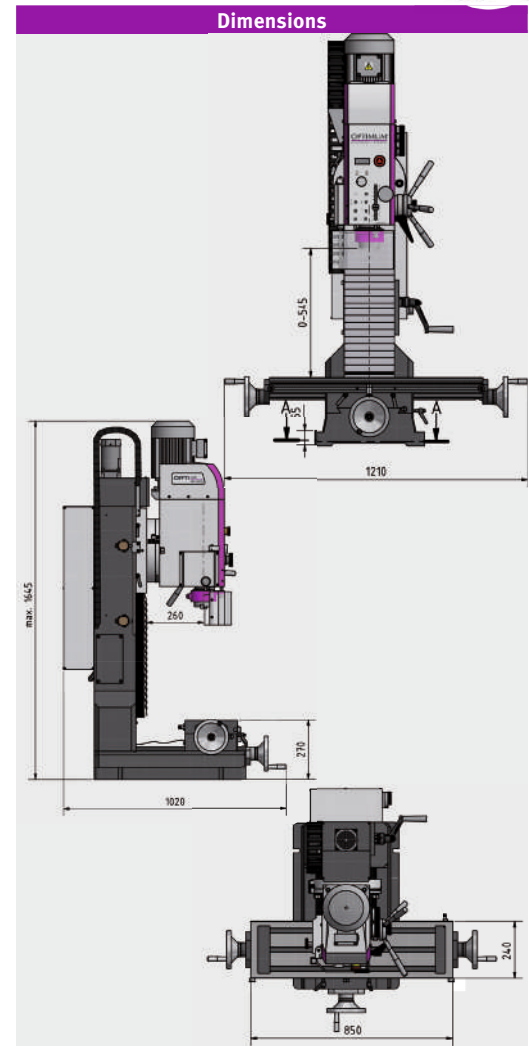

Scope of supply

- › Operating tool

Accessories	Article no.
Starter set BT 40	3353284
› Milling head holder Ø 27 mm	
› Quick-action drill chuck 1 - 13 mm	
› 2 pcs. Weldon Ø 6 mm and 20 mm	
› 1 pc. each Weldon Ø 8 / 10 / 12 / 16 mm	
› BT 40 - MT 3 adapter	
› 3 pcs. spring collet holder ER 32	
› Spring collet key ER 32	
› 18-part Collet kit ER 32	
› Height-adjuster	
› Assembly and tool adjustment gauge	
› 14 pcs. pull studs	
› Taper squeegee	

Machine vices	Article no.
FMS 125	3354125
FMSN 125	3354120
VMQ 100	3354181
MV3-75	3354175
DAS 100	3355500
ZAS 50	3354170
› Information about vices from page 116	

Preface

Drilling

Milling

Turning

Saws

Grinding

Polishing

Lamps

Measuring

Universal precision drilling/milling machines with manual gearbox. MH 35V with electronically controlled drive. Control unit with dirt- and water-resistant membrane keyboard

Facts that impress in terms of quality, performance and price

- ▶ Control panel with user-friendly dirt and water resistant foil keyboard
 - ▶ Easily readable digital display
 - ▶ Easily readable spindle sleeve display in milling head
 - ▶ Drilling depth stop
 - ▶ Thread tapping mode
 - ▶ Right-handed/left-handed rotation
 - ▶ Rotary pushbutton on control panel for adjusting the drilling depth, optionally in mm or inches, with zero point
 - ▶ Excellent concentricity thanks to tapered roller bearings, better than 0.015 mm measured in the spindle sleeve
 - ▶ Gear head pivots through $\pm 30^\circ$
 - ▶ Manual fine feed
 - ▶ Adjustable cleats
 - ▶ Z axis with slatted, stainless steel protective cover
- ▶ Height-adjustable protective screen with microswitch for best possible user protection against chips and parts being flung out
 - ▶ Solid and generously dimensioned cross table with precision surface finish and T-slots
 - ▶ Heavy, sturdy and solid columns made of premium cast material with ground and shaven dovetail guide for excellent stability and precision
 - ▶ Optional, solid, heavy steel chassis ensures stability

MH 35G:

- ▶ Two-stage industrial quality electric motor

MH 35V:

- ▶ 6 speeds, electronically controlled



Energy chain

- › cable guidance easy on material



Mechanical

Quick change clamping system

- The milling head is equipped with spring collet for pull stud BT30x45°
- › Easy to change by unlocking the mechanical safeguard and moving the spindle sleeve lever upward



- › Depth selection freely configurable via digital display
- › In speed mode, the machine automatically switches over from clockwise to anti-clockwise run.



Fig.: MH 35V

Technical specifications, accessories and dimensions

Model	MH 35G	MH 35V***
Article no.	3338165	3338170
Technical data		
Electrical connection	400 V / 3 Ph ~50 Hz	
Motor output	1.1 / 1.5 kW	1.5 kW
Drilling/milling output		
Drilling performance in steel (S235JR)	Ø 32 mm	
Continuous drilling performance in steel (S235JR)	Ø 28 mm	
Max. sensor head size	Ø 80 mm	
Max. shaft milling cutter size	Ø 28 mm	
Spindle		
Spindle sleeve stroke	90 mm	
Spindle seat	BT 30	
Spindle sleeve diameter	68 mm	
Throat	215 mm	
Drilling/milling head		
Spindle speeds	220 - 3 100 rpm	50 - 3 260 rpm
Speeds	2 x 6 speeds	6 speeds Electr. controlled
Pivot range	± 30°	
Cross table		
Length x width	750 mm / 210 mm	
T-slot size / spacing / count	12 mm / 63 mm / 3	
Load bearing capacity	max. 170 kg	
Clearance spindle to cross table max.	440 mm	
Travel		
X axis	450 mm	
Y axis	200 mm	
Z axis	460 mm	
Dimensions		
Length x width x height	850 / 1 030 / 1 340 mm	
Weight	316 kg	

Accessories	Article no.
Milling head holder Ø 22 mm	3353306
Quick clamping drill chuck 1 - 13 mm	3536303
Weldon holder Ø 6 mm	3353310
Weldon holder Ø 8 mm	3353311
Weldon holder Ø 10 mm	3353312
Weldon holder Ø 12 mm	3353313
Weldon holder Ø 16 mm	3353314
Weldon holder Ø 20 mm	3353315
Adapter BT 30 - MT 2	3353305
Spring collet holder ER 32	3353304
Spring collet holder spanner ER 32	3353307
Collet kit ER 32	3441122
Height-adjuster	3536290
Assembly and tool adjustment gauge	3536193
Taper squeegee	3353301
Pull stud 40 x 45° M12	3353302
Pull stud DIN2080 M12	3536177
Universal table feed V99	3352022
Assembly kit V99 - X axis	3352035
Assortment of clamping tools size 10, 58-parts	3352016
Steel chassis (information on page 131)	3353014
Levelling platen SE 55 (4 pcs. required)	3352981
Vibration damping machine base SE1 (4 pcs. required)	3381012
› More accessories for milling machines from page 122	

** Important information on transport surcharge and „Operation of machines with frequency converters“ on page 249
***The milling machine complies with the DIN EN 55011 standard: class C2.

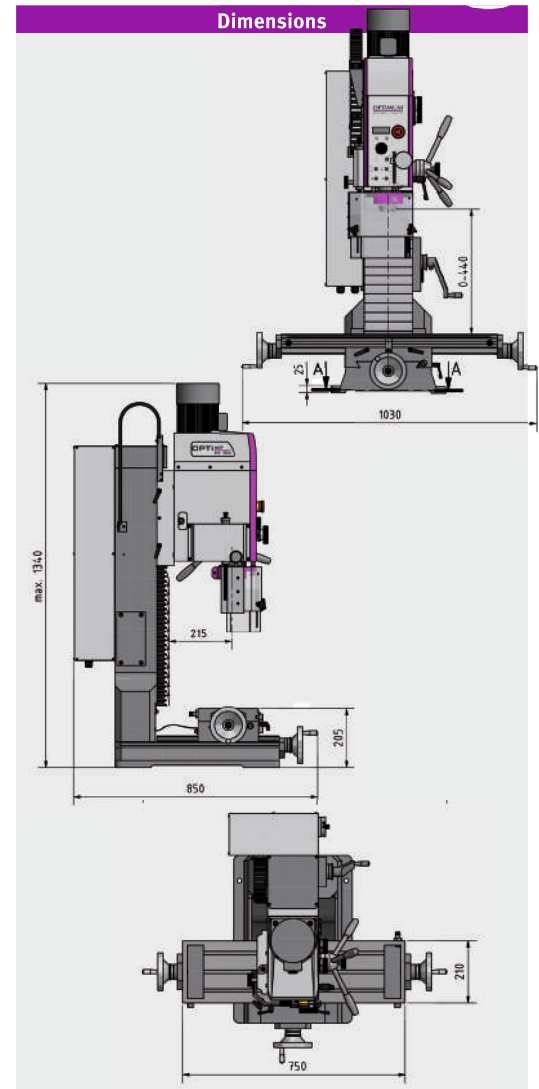

Scope of supply

› Operating tool

Machine vices	Article no.
FMS 125	3354125
VMQ 100	3354181
MV3-75	3354175
DAS 100	3355500
ZAS 50	3354170

Accessories	Article no.
Starter set BT 30	3353282
› Milling head holder Ø 22 mm	
› Quick-action drill chuck 1 - 13 mm	
› 2 pcs. Weldon Ø 6 mm and 20 mm	
› 1 pc. each Weldon Ø 8 / 10 / 12 / 16 mm	
› BT 30 - MT 2 adapter	
› 3 pcs. spring collet holder ER 32	
› Spring collet key ER 32	
› 18-part Collet kit ER 32	
› Height-adjuster	
› Assembly and tool adjustment gauge	
› 14 pcs. pull studs	
› Taper squeegee	

Preface

Drilling

Milling

Turning

Saws

Grinding

Polishing

Lamps

Measuring

Universal precision drilling/milling machine with manual gearbox for optimum power transmission

Facts that impress in terms of quality, performance and price

- ▶ Heavy, solid cast design
- ▶ Two-stage industrial quality electric motor
- ▶ Operation-friendly control panel with emergency stop shock switch
- ▶ Thread tapping function
- ▶ Height-adjustable, large protective screen
- ▶ Manual spindle sleeve feed with fine feed
- ▶ Smooth action due to polished gearwheels running in an oil sump
- ▶ Drilling depth stop
- ▶ Large speed range from 95 - 3 200 rpm thanks to 12 different speeds
- ▶ Right-handed/left-handed rotation
- ▶ Gear head pivots through $\pm 60^\circ$
- ▶ Column with dovetail guide, hand honed
- ▶ Solid and generously dimensioned cross table with precision surface finish and adjustable cleats
- ▶ Adjustable cleats

"Thread tapping" operating mode

- › The motor is activated by moving the spindle sleeve down
- › When the preset depth is reached, the spindle reverses
- › The machine thread tapping drill moves back out of the workpiece
- › When the spindle sleeve has moved in to the switching point, the spindle rotation is stopped



Accessories

Steel chassis

Dimensions L x W x H: 650 x 550 x 750 mm

Art. no. 3353014

Vibration dampers machine base SE 1

(4 pcs. needed)

Art. no. 3381012



Fig. MB 4 with optional accessories

Technical specifications, accessories and dimensions

Model	MB 4
Article no.	3338450
Technical data	
Electrical connection	400 V / 3 Ph ~ 50 Hz
Motor output	1.1 / 1.5 kW
Drilling/milling output	
Drilling performance in steel (S235JR)	Ø 32 mm
Continuous drilling performance in steel (S235JR)	Ø 28 mm
Max. sensor head size	Ø 63 mm
Max. shaft milling cutter size	Ø 28 mm
Spindle	
Spindle sleeve stroke	120 mm
Spindle seat	MT 4
Spindle sleeve diameter	75 mm
Throat	275 mm
Draw-in rod	M16
Drilling/milling head	
Spindle speeds	95 - 3 200 rpm
Speeds	2 x 6 speeds
Pivot range	± 60°
Cross table	
Length x width	800 x 240 mm
T-slot size / spacing / count	14 mm / 63 mm / 3
Load bearing capacity	80 kg
Clearance spindle to cross table	460 mm
Travel	
X axis	450 mm
Y axis	195 mm
Z axis	430 mm
Dimensions	
Length x width x height	1 155 x 775 x 1 420 mm
Weight	320 kg

Accessories	Article no.
Parallel shim set, 20-part	3354001
Horizontal-vertical rotary indexing table RT 100	3356110
Horizontal-vertical rotary indexing table RT 150	3356150
Horizontal-vertical rotary indexing table RTE 165	3356365
Height-adjustable tailstock RST 1	3356155
Assortment of clamping tools size 12, 58-parts	3352017
T-slot nut M12 / 14 mm	3353025
Blank holder 14 mm	3352031
End mill set HSS TiN-coated 12-part	3352250
End mill set HSS TiN-coated 20-part	3352255
Copying and facing blade MT 4	3350214
Vibration dampers SE1 (4 pcs. required)	3381012
Levelling platen SE 55 (4 pcs. required)	3352981
Bore head set MT 4	3352084
Arbor for drill chuck MK4	3350304
Collet chuck MT 4/M16	3352094
Thread tapping chuck M3 - M12	3050705
Thread tapping chuck M8 - M20	3050706
Universal table feed V99	3352022
Assembly kit V99 - X axis	3352035
Universal coolant unit 230 V	3352002
Coolant mist lubricator MMC 1 with magnetic holder	3356663
Coolant hose KMS 2	3356660
Steel chassis (information on page 131)	3353014

› More „Accessories for milling machines“ from page 126

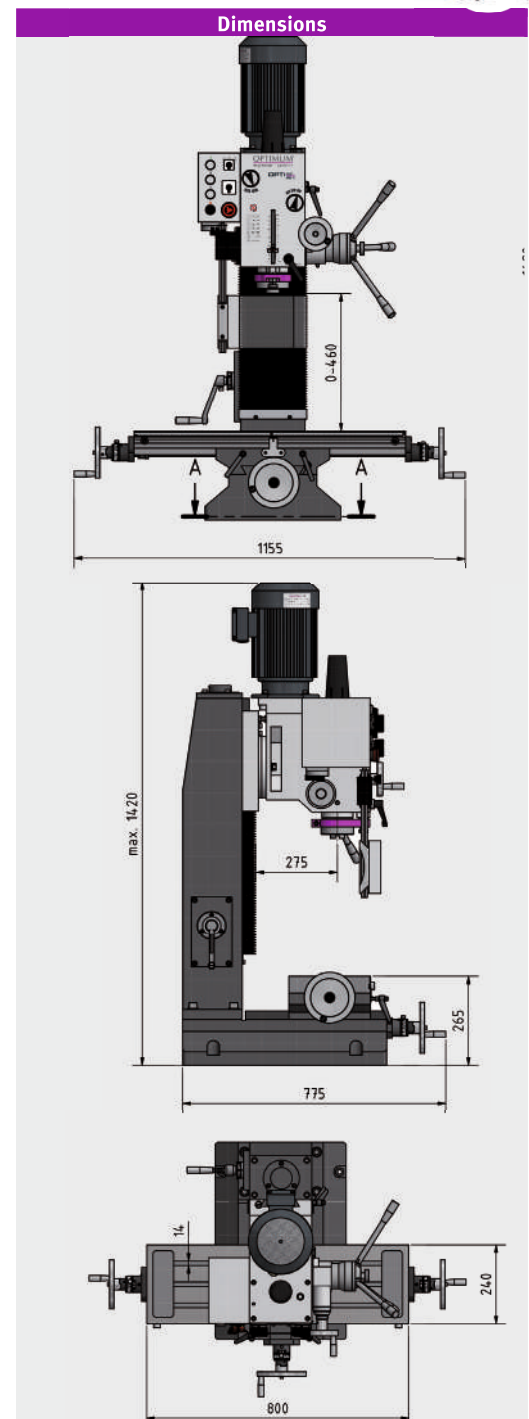

Scope of supply

- › Adapter MT 4 - MT 3
- › Draw-in rod M16
- › Operating tool

Machine vices	Article no.
FMS 100	3354100
FMS 125	3354125
FMSN 125	3354120
VMQ 100	3354181
MV3-75	3354175
DAS 100	3355500
ZAS 50	3354170

› Information about vices from page 116

Sturdy milling machines with continuously variable electronic speed control. MH 25SV with stepper motors and digital position display DRO 5

Facts that impress in terms of quality, performance and price

- ▶ Inverter motor
- ▶ Precision workmanship
- ▶ Particularly smooth action
- ▶ Counterweight facilitates Z axis adjustment
- ▶ Variable speed control
- ▶ Easy tool changing thanks to tool quick clamping system
- ▶ Wide rail on Z axis
- ▶ Groove prepared for easy retroactive mounting of magnetic strips
- ▶ Feed spindles can be adjusted thanks to adjustable spindle nuts
- ▶ Sturdy dovetail guide, precision ground and shaved with adjustable cleats
- ▶ Angular ball bearings on the axes
- ▶ Drilling/milling head pivots through $\pm 45^\circ$
- ▶ Right-handed/left-handed rotation

- ▶ Height-adjustable protective screen with microswitch
- ▶ Limit switches for all three axes

MH 25V:

- ▶ Easily readable speed display in milling head

MH 25SV:

- ▶ Continuously variable feed on all axes
- ▶ Rapid motion X/Y axis for fast positioning
- ▶ Digital 3-axis position display DRO 5
- ▶ Feed cut-off at end position
- ▶ Transportable control panel
- ▶ The feed switches off when the spindle is stationary



Mechanical quick change clamping system

- › The milling head is equipped with spring collet for pull studs BT30x45°
- › Easy to change by turning an Allen key in the adapter bore.

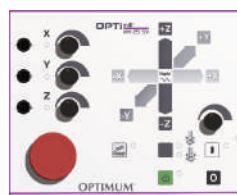

Control panel MH 25SV



Control panel MH 25V

- › User-friendly membrane keyboard with touch and switch control
- › Easy to clean



Energy chain

- › cable guidance easy on material



Control panel

- › Excellent operability
- › Good mobility thanks to ability to remove control panel from holder (MH 25SV)



Fig.: MH 25SV

Technical specifications, accessories and dimensions

Model	MH 25V	MH 25SV
Article no.	3338155	3338160
Technical specifications		
Electrical connection	230 V / 1 Ph ~50 Hz	
Total rated value	2 kW	
Milling spindle		
Drive motor	1.5 kW	
Drive motor torque	10 Nm	
Drilling/milling output		
Max. sensor head size	Ø 52 mm	
Max. shaft milling cutter size	Ø 25 mm	
Spindle		
Spindle seat	BT 30	
Throat	185 mm	
Drilling/milling head		
Spindle speeds	200 - 4 000 rpm	
Speeds	Electronic speed control	
Pivot range	45°	
Cross table		
Length x width	620 x 180 mm	
T-slot size / spacing / count	12 mm / 50 mm / 3	
Cross table max. load bearing capacity	30 kg	
Clearance spindle to cross table	300 mm	
Travel		
X axis	manual 400 mm	automatic 380 mm
Y axis	manual 210 mm	automatic 130 mm
Z axis	manual 270 mm	automatic 190 mm
Torque		
X/Y/Z axis	-	2.2 / 2.2 / 4.2 Nm
Travel speeds		
X axis	-	150 - 930 mm/min.
Y axis	-	100 - 580 mm/min.
Z axis	-	80 - 450 mm/min.
Dimensions		
Length x width x height	970 x 975 x 1 025 mm	
Weight	192 kg	200 kg

Accessories	Article no.
Milling head holder Ø 22 mm	3353306
Chuck 1 - 13 mm	3536303
Weldon holder Ø 6 mm	3353310
Weldon holder Ø 8 mm	3353311
Weldon holder Ø 10 mm	3353312
Weldon holder Ø 12 mm	3353313
Weldon holder Ø 16 mm	3353314
Weldon holder Ø 20 mm	3353315
Adapter BT 30 - MT 2	3353305
Spring collet holder ER 32	3353304
Spring collet holder spanner ER 32	3353307
Collet kit ER 32	3441122
Height-adjuster	3536290
Assembly and tool adjustment gauge	3536193
Taper squeegee	3353301
Pull stud 40 x 45° M12	3353302
Pull stud DIN2080 M12	3536177
Assortment of clamping tools size 10, 58-parts	3352016
Universal chassis (information on page 131)	3353009
› More accessories for milling machines from page 122	

Important information on „Operation of machines with frequency converters“ on page 249
The milling machines comply with DIN EN 55011:2011-04 class B Directive

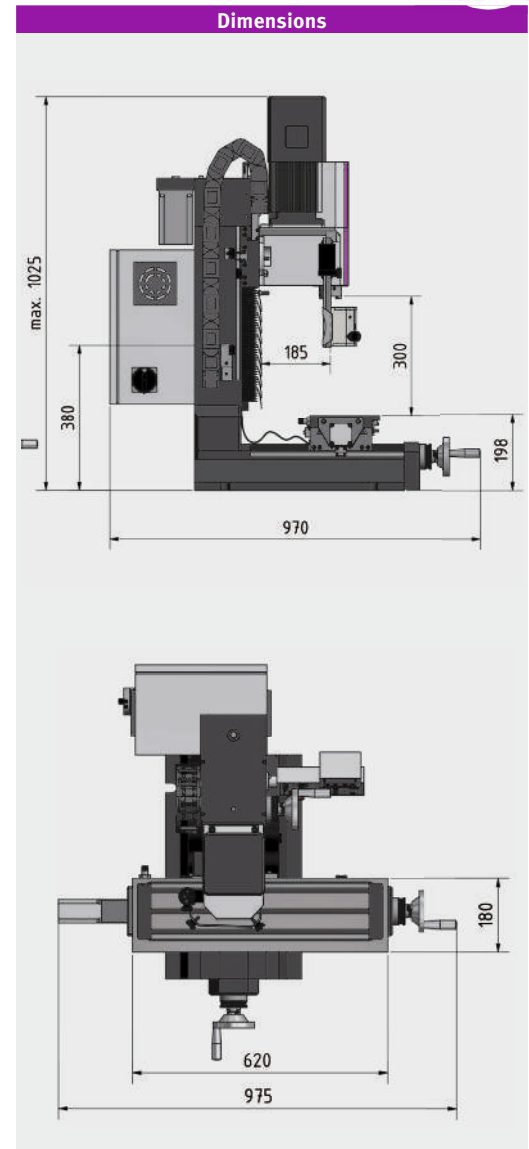

Accessories	Article no.
Starter set BT 30	3353282
› Milling head holder Ø 22 mm	
› Chuck 1 - 13 mm	
› 2 pcs. Weldon Ø 6 mm and 20 mm	
› 1 pc. each Weldon Ø 8 / 10 / 12 / 16 mm	
› BT 30 - MT 2 adapter	
› 3 pcs. spring collet holder ER 32	
› Spring collet key ER 32	
› 18-part Collet kit ER 32	
› Height-adjuster	
› Assembly and tool adjustment gauge	
› 14 pcs. pull studs	
› Taper squeegee	

Machine vices	Article no.
FMS 100	3354100
VMQ 80	3354180
MV3-75	3354175
ZAS 50	3354170
› Information about vices from page 116	

Preface

Drilling

Milling

Turning

Saws

Grinding

Polishing

Lamps

Measuring

Sturdy drilling/milling machines with continuously variable electronic speed control. MH 22VD with digital position display DRO 5

Facts that impress in terms of quality, performance and price

- ▶ Precision workmanship
- ▶ Clear-cut control panel with user friendly membrane keyboard
- ▶ Safety electrical system 24-volt version
- ▶ Easily readable digital display for speed and drilling depth
- ▶ Emergency stop button
- ▶ Motor with two-speed gear ratio for powerful transmission of motor output
- ▶ Powerful DC motor with permanent current monitoring
- ▶ Control electronics with integrated relay control
- ▶ Drilling/milling head pivots through $\pm 90^\circ$ for milling and drilling work in any angled position
- ▶ Feed spindles can be adjusted without play thanks to adjustable spindle nuts
- ▶ Right-handed/left-handed rotation
- ▶ Machine lamp
- ▶ Excellent concentricity thanks to tapered roller bearings, ≤ 0.015 mm measured in the spindle sleeve
- ▶ Sturdy dovetail guide with adjustable V-ledges
- ▶ Solid cross table with precision surface and T-slots
- ▶ Adjustable cleats
- ▶ Adjustable limit stops
- ▶ Bore for easy oiling of the trapezoidal spindle
- ▶ Two-row angular contact ball bearings in the axes, adjustable without play
- ▶ Gaiter as guide protection
- ▶ Height-adjustable protective screen with microswitch for best possible user protection against chips and parts being flung out
- ▶ Fine feed

MH 20V

X, Y and Z column axis with groove prepared for easy retroactive mounting of magnetic strips

MH 22VD

▶ With digital position display DRO 5



Energy chain

› cable guidance easy on material

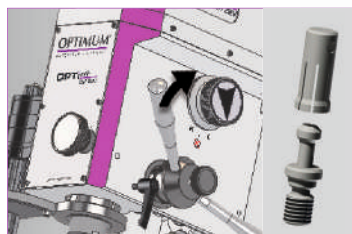

Mechanical quick change clamping system MH 22V / MH 22VD

- › The milling head is equipped with spring collet for pull studs BT30x45°
- › Easy to change by moving the spindle sleeve levers upward



Fig.: MH 22VD with optional accessories

Technical specifications, accessories and dimensions

Model	MH 20V	MH 22V
Article no.	3338115	3338135
Model		MH 22VD
Article no.	-	3338136

Technical data		
Electrical connection	230 V / 1 Ph ~50 Hz	
Motor output	750 W	950 W
Drilling/milling output		
Drilling performance in steel (S235JR)	Ø 16 mm	Ø 20 mm
Cont. drilling performance steel	Ø 12 mm	Ø 16 mm
Max. sensor head size	Ø 52 mm	Ø 52 mm
Max. shaft milling cutter size	Ø 20 mm	Ø 12 mm
Spindle		
Spindle sleeve stroke	50 mm	
Spindle sleeve diameter	Ø 60 mm	
Spindle seat	MT 2	BT 20
Throat	170 mm	170 mm
Drilling/milling head		
Spindle speeds	100 - 3 000 rpm	90 - 3 000 rpm
Speeds	2-speed, electronic speed control	
Pivot range	± 90°	
Cross table		
Length x width	510 x 180 mm	700 x 180 mm
T-slot size / spacing / count	12 mm / 63 mm / 3	
Max. load bearing capacity	50 kg	
Clearance spindle to cross table	255 mm	360 mm
Travel		
X axis	280 mm	480 mm
Y axis	175 mm	175 mm
Z axis	210 mm	270 mm
Dimensions		
Length x width x height	750 x 650 x 820 mm	745 x 650 x 950 mm
Overall weight	94 kg	120 kg

Accessories	Article no.
NEW Starter kit BT 20 (info on page 127)	3353281
Milling head holder Ø 16 mm BT 20	3352728
Chuck adapter BT 20 - B16	3352727
Weldon holder Ø 6 mm BT 20	3352732
Weldon holder Ø 8 mm BT 20	3352734
Weldon holder Ø 10 mm BT 20	3352736
Weldon holder Ø 12 mm BT 20	3352738
Collet chuck ER 16	3352741
Spring collet holder spanner ER 16	3352742
Collet kit ER 16, 12-part, 1 - 10 mm	3440282
Pull stud BT 20	3352726
Quick clamping drill chuck 1 - 13 mm; B16	3050623
Collet kit MT 2/ M10, direct	3351980
Collet kit ER 25, 15-part	3441109
End mill set HSS TiN-coated	3352250
NEW Assembly kit for DRO5 on MH20V/MH22V	3383990
Universal chassis (information on page 131)	3353000
Chip tray (information on page 131)	3352999
Levelling platen SE 55 (4 pcs. required)	3352981
› More accessories for milling machines from page 122	

Machine vice	Article no.
VMQ 80	3354180
› Information about vices from page 116	



Dimensions MH 20V

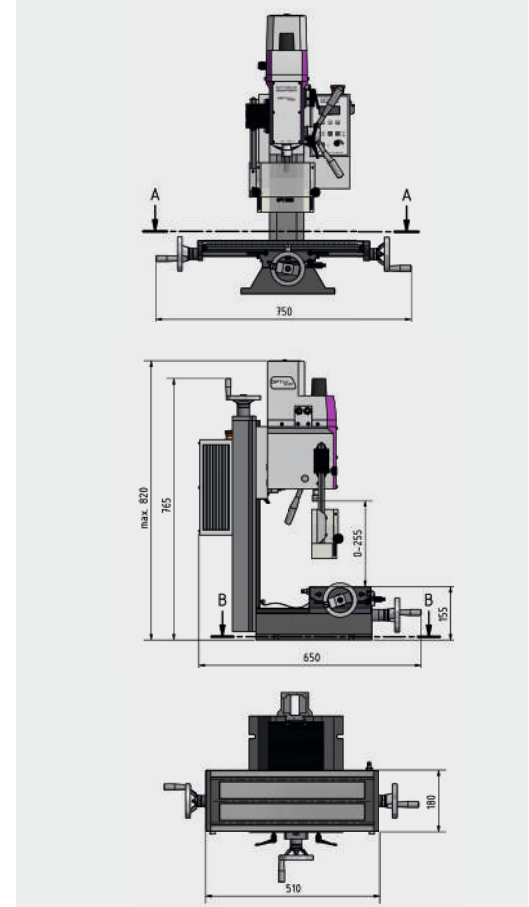

Dimensions MH 22V

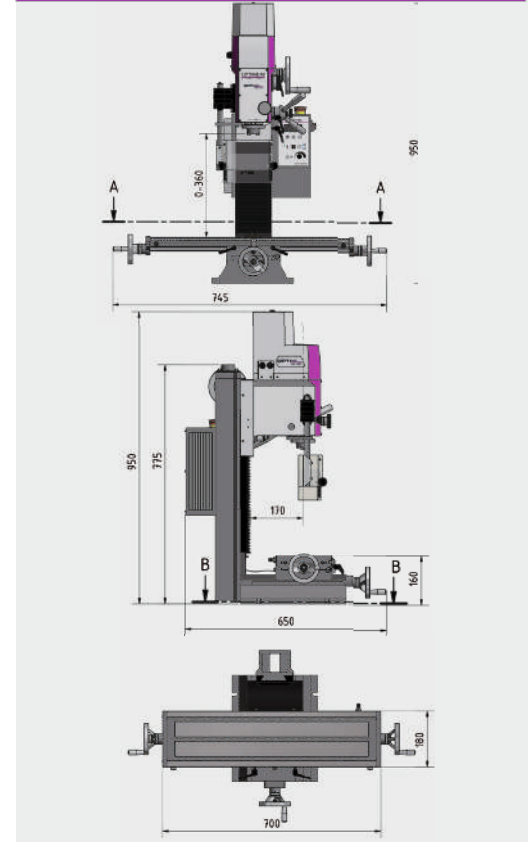

Preface

Drilling

Milling

Turning

Saws

Grinding

Polishing

Lamps

Measuring

Small drilling/milling machine with electronic, continuously controllable drive for model makers

Facts that impress in terms of quality, performance and price

- ▶ Versatile deployment options
- ▶ Two-speed transmission ratio
- ▶ Tool holder MT 2
- ▶ Safety electrical system 24-volt version
- ▶ EMC filter class C1
- ▶ Drilling-milling head pivots through $\pm 90^\circ$ for drilling and milling work at angles when required
- ▶ Height-adjustable, large protective screen with micro switch
- ▶ Precise feed thanks to positioning capable scale rings on all handwheels
- ▶ Simple and clear-cut operating unit with on/off switch, potentiometer and emergency-stop shock switch
- ▶ Infinitely variable speed from 100 to 3 000 rpm
- ▶ Excellent concentricity thanks to tapered roller bearings, better than 0.015 mm measured in the spindle sleeve
- ▶ Stable column with dovetail guide, adjustable on all 3 axes via V-ledges
- ▶ Feed spindle play adjustable and re-adjustable
- ▶ Column can be displaced laterally to extend the range of applications
- ▶ Solid cross table with T-slots, coolant channel and adjustable limit stops
- ▶ Longitudinal scale inset in Cross table
- ▶ All travel can be read off on scales
- ▶ Perfect milling surface thanks individually clampable guideways
- ▶ Inexpensive, lasting value



Accessories

Digital position display DRO 5
Art. no. 3383975

Factory assembly DRO 5
Art. no. 9000420

Magnetic strip per metre
Art. no. 3383980

Accessories

Universal chassis
Dimensions L x B x W: 420 x 340 x 800 mm
Art. no. 3353000

Chip tray
Dimensions L x W x H: 720 x 470 x 30 mm
Art. no. 3352999

Vibration dampers machine base SE 1
(4 pcs. needed)
Art. no. 3381012



Fig.: BF 16 Vario with optional accessories

Technical specifications, accessories and dimensions

Model	BF 16 Vario
Article no.	3338116
Technical data	
Electrical connection	230 V / 1 Ph ~50 Hz
Motor output	500 W
Drilling/milling output	
Drilling performance in steel (S235JR)	Ø 16 mm
Continuous drilling performance in steel (S235JR)	Ø 12 mm
Max. sensor head size	Ø 52 mm
Max. shaft milling cutter size	Ø 20 mm
Spindle	
Spindle sleeve stroke	50 mm
Spindle seat	MT 2 / M10
Throat	170 mm
Draw-in rod	M 10
Drilling/milling head	
Spindle speeds	100 - 3 000 rpm
Speeds	2-speed, electronic speed control
Pivot range	± 90°
Cross table	
Length x width	400 x 120 mm
T-slot size / spacing / count	10 mm / 35 mm / 3
Clearance spindle to cross table	275 mm
Travel	
X axis	220 mm
Y axis	160 mm
Z axis	210 mm
Dimensions	
Length x width x height	505 x 465 x 795 mm
Weight	62 kg

Accessories	Article no.
Collet kit MT 2 / M10, 5-part	3351980
Collet kit ER 25, 15-part	3441109
Collet chuck set MT 2/ ER 25	3352052
Collet chuck set MT 2/ ER 32	3352053
End mill set HSS TiN-coated 12-part	3352250
End mill set HSS TiN-coated 20-part	3352255
Quick clamping drill chuck 1 - 13 mm B16	3050623
Assortment of clamping tools size 8	3352015
T-slot nut M 8 / 10 mm	3353020
Universal coolant unit 230 V	3352002
Coolant mist lubricator MMC 1 with magnetic holder	3356663
Coolant hose KMS 2	3356660

› **More accessories for milling machines** from page 122

Machine vice	Article no.
VMQ 80	3354180

› Information about vices from page 116

Important information on „Operation of machines with frequency converters“ on page 249
The milling machine complies with the DIN EN 55011 standard: class C1.

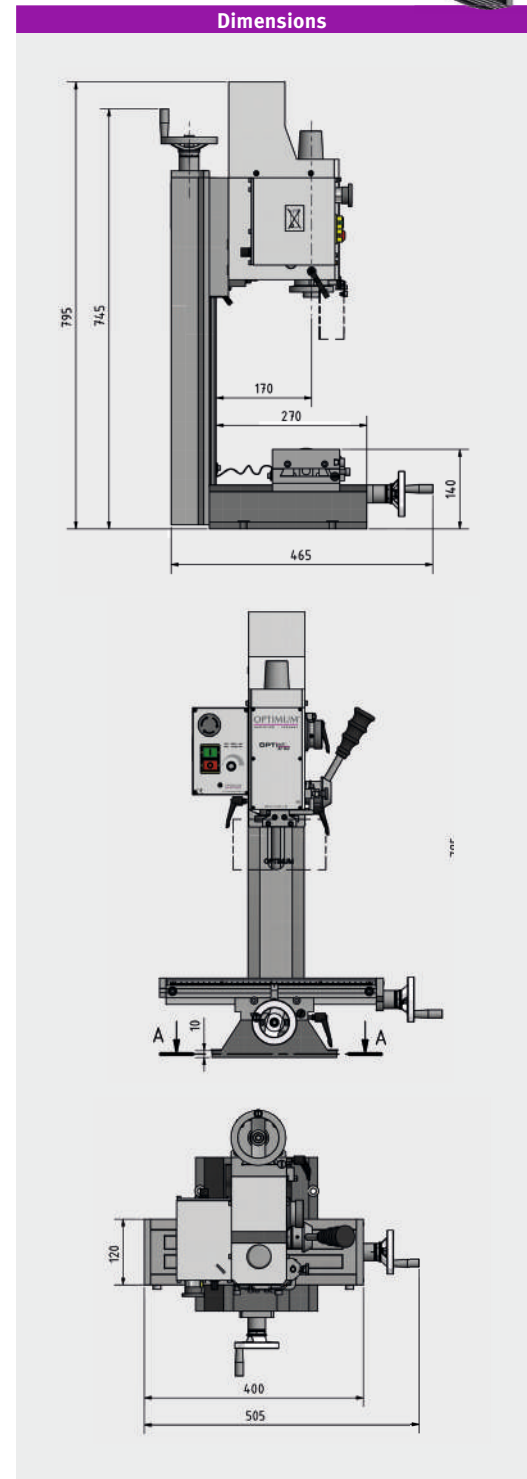

Scope of supply

- › Tapered mandrel MT 2/B16
- › Draw-in rod M10
- › Operating tool

Preface

Drilling

Milling

Turning

Saws

Grinding

Polishing

Lamps

Measuring

Compatibility overview vises for milling machines

Accessories		Article no.	BF 16	MH 20	MH 22	MH 25	MB 4	MH 35	MH 50	MB 4P	MB 4PV	MT 50E	MT 50	MT 60	MF 2-B	MF 4-B	MF 2V	MF 4V	MT 130	MT 100	MT 200	MT 230	MT 8	MZ 2	MZ 4	
Machine vices FMS	100	3354100	●	●	●	●	●			●	●															
	125	3354125					●	●	●	●	●	●	●	●	●		●								●	●
	150	3354150														●		●	●	●					●	●
	200	3354200																			●	●	●			
Machine vices HMS	100	3355100					●	●		●	●															
	125	3355127													●	●	●	●	●	●	●	●		●	●	
	150	3355150																					●		●	
	200	3355200																						●	●	
Machine vices FMSN	100	3354110	●	●	●	●																				
	125	3354120					●	●	●	●	●	●	●	●	●	●	●	●	●	●	●	●		●	●	
	150	3354130														●		●	●	●			●	●	●	
Machine vices VMQ	80	3354180	●	●	●	●																				
	100	3354181	●	●	●		●	●	●	●	●	●	●	●	●	●	●	●	●	●	●	●		●	●	
	125	3354182														●		●	●	●			●	●	●	
	150	3354183																						●	●	
Three-axis vices MV3	75	3354175	●	●	●	●	●	●	●	●	●	●	●	●	●	●	●	●	●	●	●	●	●	●	●	●
	125	3354178											●	●	●	●	●	●	●	●	●	●	●	●	●	●
Two-axis vice ZAS	50	3354170	●	●	●	●	●	●	●	●	●	●	●	●	●	●	●	●	●	●	●	●	●	●	●	●
Three-axis vice DAS	100	3355500					●	●	●	●	●	●	●	●	●	●	●	●	●	●	●	●	●	●	●	●
Machine vice HCV	105	3536210													●	●	●	●	●	●	●	●	●	●	●	●
	125	3536214													●	●	●	●	●	●	●	●	●	●	●	●
Machine vice MVSP	150 x 200	3530104																						●	●	
	150 x 200	3530108																						●	●	

Machine vices

Precision machine vices FMS

- › Robust design for milling, drilling and grinding
- › Vice body made of premium cast material
- › Guide surfaces tempered and polished
- › Hardened and polished clamping jaws, replaceable
- › With turntable, rotating through 360°

	Art.no.
FMS 100	3354100
FMS 125	3354125
FMS 150	3354150
FMS 200	3354200
Prism jaws	Art.no.
for FMS 100	3354102
for FMS 125	3354127
for FMS 150	3354152
for FMS 200	3354202

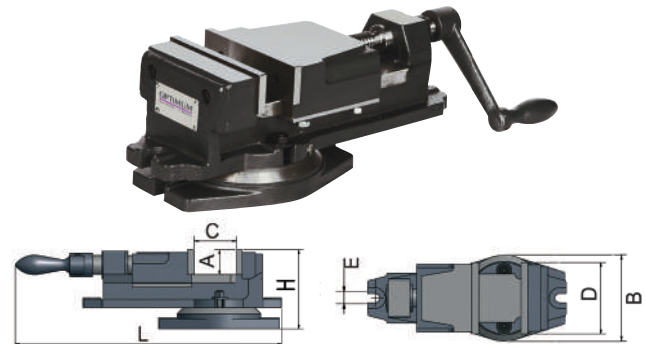

Tech. data	A	C	D	E	L	B	H	kg
FMS 100 mm	30	62	100	13	295	124	100	11
FMS 125 mm	37	85	125	13	370	148	128	17
FMS 150 mm	40	114	150	13	462	180	145	28
FMS 200 mm	58	150	200	16.5	620	237	202	58

Hydraulic machine vices HMS

- › Robust design for milling, drilling and grinding
- › Vice body made of premium cast material
- › Guide surfaces tempered and polished
- › Booster system: requires little force, high pressure build-up during clamping
- › Large clamping range due to lock bolts with various hole spacings
- › With turntable, rotating through 360°. Protected spindle

	Art.no.
HMS 100	3355100
HMS 125	3355127
HMS 150	3355150
HMS 200	3355200

Prism jaws	Art.no.
for HMS 100	3355102
für HMS 125	3355129
for HMS 150	3355152
for HMS 200	3355202

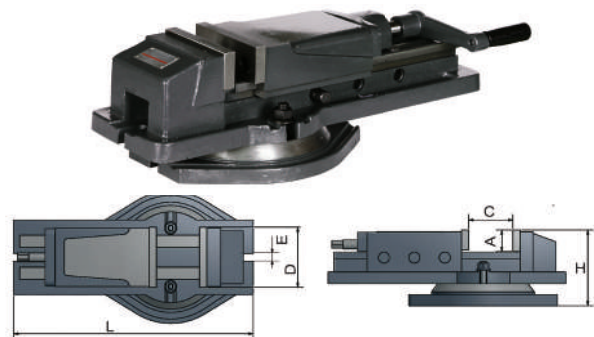

	A	D	E	L	B	H	kg
HMS 100 mm	36	100	15	525	Ø 270	122	27
HMS 125 mm	46	127	16	670	Ø 290	151	46
HMS 150 mm	51	150	17	800	Ø 328	169	64
HMS 200 mm	65	200	19	710	Ø 358	158	100

	C	Span	Clamping pressure	
HMS 100	0 - 60 mm	57 - 115 mm	110 - 170 mm	2 500 kg 24.5 kN
HMS 125	0 - 76 mm	72 - 150 mm	146 - 224 mm	4 000 kg 39.25 kN
HMS 150	0 - 100 mm	98 - 200 mm	195 - 300 mm	4 500 kg 44.1 kN
HMS 200	0 - 100 mm	98 - 200 mm	195 - 300 mm	7 500 kg 73.6 kN

Precision machine vices FMSN

- › Vice body made of premium cast material
- › Guide surfaces tempered and polished
- › Hardened and polished clamping jaws, replaceable
- › Protected spindle
- › Clamping outward by repositioning the clamping jaws
- › With turntable, rotating through 360°

	Art.no.
FMSN 100	3354110
FMSN 125	3354120
FMSN 150	3354130

Prism jaws	Art.no.
for FMSN 100	3354112
for FMSN 125	3354122
for FMSN 150	3354132

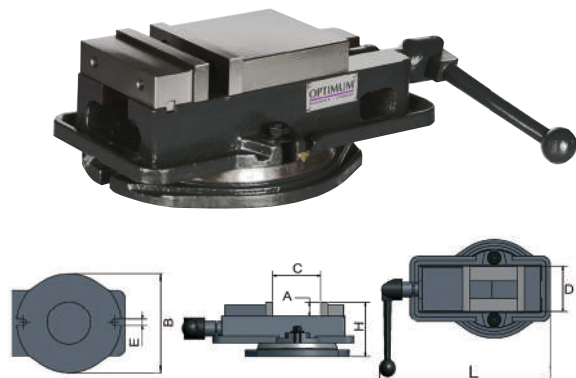

Tech. data	A	C	D	E	L	B	H	kg
FMSN 100 mm	36	101	100	14.5	319	Ø 240	319	19
FMSN 125 mm	36	108	135	16.5	369	Ø 278	369	29
FMSN 150 mm	46	146	155	18.5	425	Ø 332	425	36

Preface

Drilling

Milling Accessories

Turning

Saws

Grinding

Polishing

Lamps

Measuring

Machine vices

Milling machine vices VMQ

- › Robust design for milling, drilling and grinding
- › Vice body made of premium cast material
- › Guide surfaces tempered and polished
- › Hardened and polished clamping jaws
- › With turntable, rotating through 360°

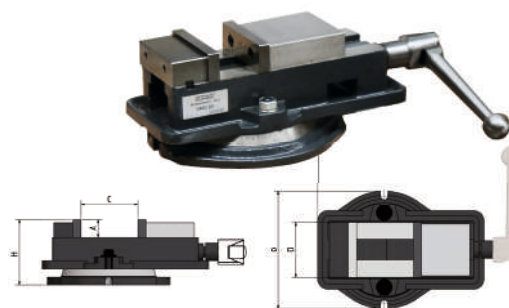

	Art. no.
VMQ 80	3354180
VMQ 100	3354181
VMQ 125	3354182
VMQ 150	3354183

Tech. data	A	C	D	L	B	H	kg
VMQ 80 mm	26	80	80	305	160	100	9.5
VMQ 100 mm	34	105	105	385	222	126	21
VMQ 125 mm	36	130	134	430	247	135	30
VMQ 150 mm	46	145	158	488	290	162	39

Three-axis vice MV3

- › Horizontal swivel movement to 90°
- › Vertical swivel movement to ± 45°
- › Hardened and polished clamping jaws
- › With turntable, rotating through 360°



	Art. no.
MV3-75	3354175
MV3-125	3354178

Tech. data	A	C	D	E	L	B	H	kg
MV3-75 mm	34	82	75.5	12	380	139	150	11
MV3-125 mm	45	97	125	12	290	185	206	26

Two-axis vice ZAS

- › Tilts to -90°
- › Hardened and polished clamping jaws
- › Easily readable scales for both axes
- › With turntable, rotating through 360°
- › Weight 3.4 kg

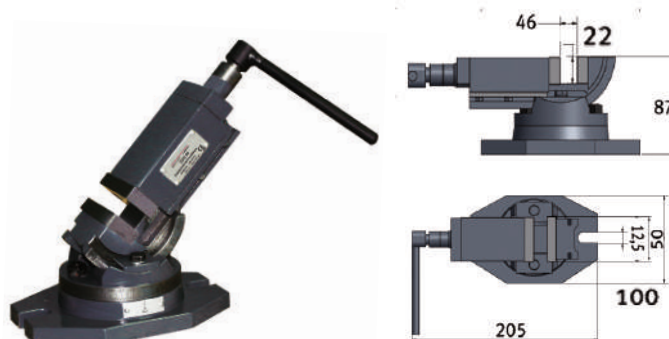

	Art. no.
ZAS 50	3354170

Three-axis vice DAS 100

- › Premium cast material
- › Guide surfaces tempered and polished
- › With turntable, rotating through 360°
- › Horizontal swivel movement to 90°
- › Vertical swivel movement to ± 45° above thread spindle
- › Weight: 32 kg

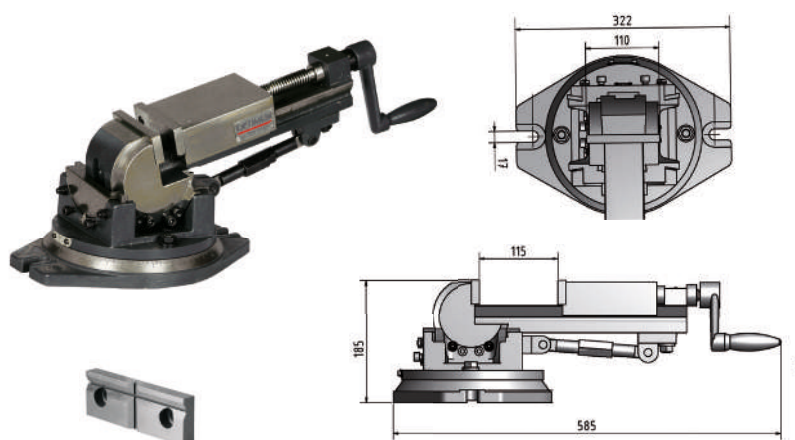

	Art. no.
DAS 100	3355500
Prism jaws for DAS 100	3355502

Hydraulic machine vice HCV 125

- › Modular machine vice with high precision and repetition accuracy for series production and single-part machining on CNC milling machines
- › Robust design for milling
- › Guide surfaces tempered and polished
- › Booster system: requires little force, high pressure build-up during clamping
- › Large clamping range due to lock bolts with various hole spacings
- › Made of premium grade stainless steel

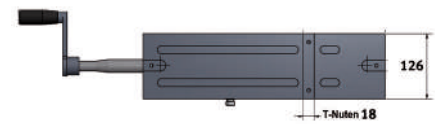
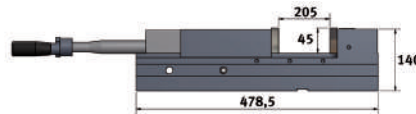
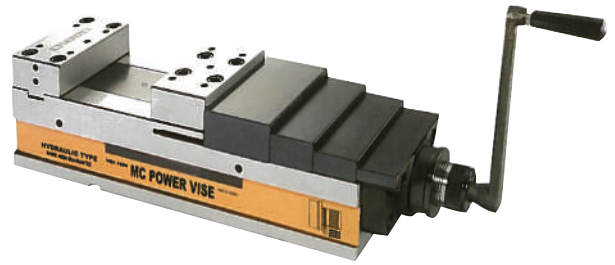

	Art. no.
HCV 125	3536214
Soft jaws 2 pcs.	3536221
L jaws 2 pcs.	3536222

Hydraulic machine vice HCV 105

- › Modular machine vice with high precision and repetition accuracy for series production and single-part machining on CNC milling machines and machining centres
- › Robust design for milling
- › Guide surfaces tempered and polished
- › Booster system: requires little force, high pressure build-up during clamping
- › Large clamping range due to lock bolts with various hole spacings
- › Made of premium grade stainless steel
- › Long service life thanks to high quality
- › High clamping force

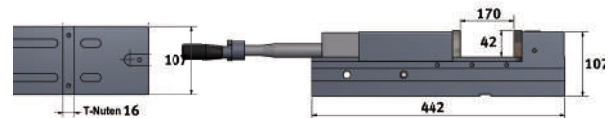
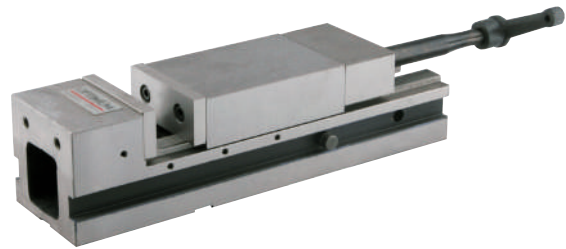

	Art. no.
HCV 105	3536210

C	Span	Clamping pressure	Weight
0 - 85 mm	85 - 170 mm	2 500 kg 24,5 kN	22 kg

Modular machine vice

- › Modular machine vice with high precision and repetition accuracy for series production and single-part machining on CNC milling machines and machining centres
- › Robust design for milling
- › Modular machine vice made completely of NiCrMo steel with hardness HRC60, tolerance 0.0015 mm
- › Mobile jaws with extra long guides to prevent lift-off and slingshot risk
- › Guide surfaces tempered and polished
- › Large clamping range due to lock bolts with various hole spacings
- › Long service life thanks to high quality
- › Includes spanner
- › Model MVSP with fixed jaws

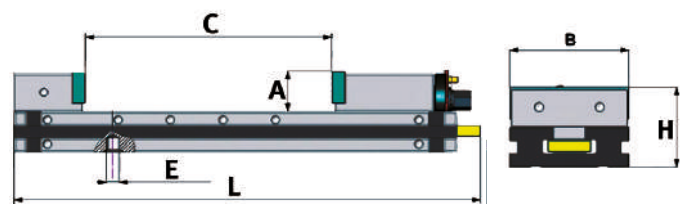
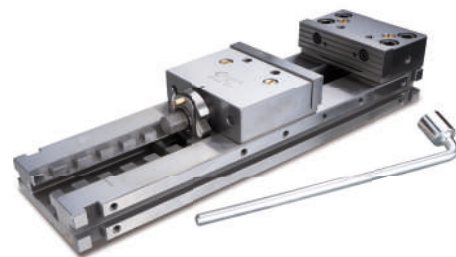

	Art. no.
MVSP 150 x 200	3530104
MVSP 150 x 300	3530108

Tech. data	A	C	E	L	B	H	kg
MVSP 150x200 mm	50	205	16	480	149	100	34
MVSP 150x300 mm	50	305	16	580	149	100	38.6

Compatibility overview accessories for milling machines

Accessories	Article no.	BF 16	MH 20	MH 22	MH 25	MB 4	MH 35	MH 50	MB 4P	MB 4PV	MT 50E	MT 50	MT 60	MF 2-B	MF 4-B	MF 2V	MF 4V	MT 130	MT 100	MT 200	MT 230	MT 8	MZ 2	MZ 4	
		MT 2	MT 2	BT 20	BT 30	MT 4	BT 30	BT 40	MT 4	MT 4	ISO 40	ISO 40	ISO 40	ISO 40	ISO 40	ISO 40	ISO 40	ISO 40	ISO 40	ISO 40	ISO 50	ISO 40	ISO 50	ISO 40	ISO 40
Horizontal-vertical rotary indexing table	RT 100	3356110	○	○	○	●	●	●	●	●	●	●	●	●	●	●	●	●	○	○	○	○	○	○	○
	RT 150	3356150				●	●	●	●	●	●	●	●	●	●	●	●	●	●	●	●	●	●	●	●
	RT 200	3356200									●	●	●	●	●	●	●	●	●	●	●	●	●	●	●
Horizontal-vertical rotary indexing table	RTE 165	3356365				●	●	●	●	●	●	●	●	●	●	●	●	●	●	●	●	●	●	●	●
	RTU 165	3354165				●	●	●	●	●	●	●	●	●	●	●	●	●	●	●	●	●	●	●	●
Universal dividing head	TA 125	3356125				○	○	○	○	○	○	●	●	○	○	○	○	●	●	●	●	●	●	●	●
End mill set HSS	12-part	3352250	●	●	●	●	●	●	●	●	●	●	●	●	●	●	●	●	●	●	●	●	●	●	●
	20-part	3352255	●	●	●	●	●	●	●	●	●	●	●	●	●	●	●	●	●	●	●	●	●	●	●
Twist drill HSS	MT 2	3051002				●										●	●	●	●					●	●
	MT 3	3051003				●		●									●	●	●	●				●	●
Milling cutter set HM	Hard metal	3352118	●	●	●	●	●	●	●	●	●	●	●	●	●	●	●	●	●	●	●	●	●	●	●
Milling cutter set HM	Radius	3352116	●	●	●	●	●	●	●	●	●	●	●	●	●	●	●	●	●	●	●	●	●	●	●
Assortment of clamping tools	Size 8	3352015	●																						
	Size 10	3352016		●	●	●		●																	
	Size 12	3352017					●		●	●	●	●	●						●	●	●			●	●
	Size 14	3352018												●	●	●	●								
	Size 16	3352019							●													●	●	●	
Edge sensor	3351171	●	●	●	●	●	●	●	●	●	●	●	●	●	●	●	●	●	●	●	●	●	●	●	●
Quick release chuck	1 - 8 mm B16	3050608	●	●	●	○	●	○	●	●	●	●	●	●	●	●	●	●	○	○	○	○	●	●	●
	1 - 10 mm B16	3050610	●	●	●	○	●	○	●	●	●	●	●	●	●	●	●	●	○	○	○	○	●	●	●
	1 - 13 mm B16	3050623	●	●	●	○	●	○	●	●	●	●	●	●	●	●	●	●	○	○	○	○	●	●	●
	1 - 16 mm B16	3050626	●	●	●	○	●	○	●	●	●	●	●	●	●	●	●	●	○	○	○	○	●	●	●
	1 - 16 mm B18	3050630																			○	○	●		
Morse cone	SK50 B18	3352067																		●	●		●		
Extension sleeve	MK2-MK3	3050667																							
	MK3-MK4	3050668																							
Reducing sleeve	MK3-MK2	3350313						●								●	●	●	●				●		●
	MK4-MK3	3350314					●		●	●															
Arbor for drill chuck	MT 2	3050670	●	●																					
	MT 4	3350304				●			●	●															
	ISO 40	3352070									●	●	●	●	●	●	●	●	●	●			●	●	●
Shank Blade head	MT 2	3352102	●	●																					
Copying and facing blade head	BT 20	3350202			●																				
	BT 30	3350203				●		●																	
	MT 2/M10	3350212	●	●																					
	BT 40	3350204																							
	MT 4/M16	3350214					●		●	●															
	ISO 40	3350216						●			●	●	●	●	●	●	●	●	●	●			●	●	●
Pull stud	BT 20	3352726			●																				
	BT 30	3536302				●		●																	
	BT 40	3536332						●																	
Precision Bore head set	ISO 40	3352128									●	●	●	●	●	●	●	●	●	●			●	●	●
	ISO 50	3352129																			●	●	●		

Accessories	Article no.	BF 16	MH 20	MH 22	MH 25	MB 4	MH 35	MH 50	MB 4P	MB 4PV	MT 50E	MT 50	MT 60	MF 2-B	MF 4-B	MF 2V	MF 4V	MT 130	MT 100	MT 200	MT 230	MT 8	MZ 2	MZ 4	
		MT 2	MT 2	BT 20	BT 30	MT 4	BT 30	BT 40	MT 4	MT 4	ISO 40	ISO 40	ISO 40	ISO 40	ISO 40	ISO 40	ISO 40	ISO 40	ISO 40	ISO 40	ISO 50	ISO 50	ISO 40	ISO 50	ISO 40
Bore head set	MT 4	3352084				●			●	●															
Collet chuck set	MT 2/ER25	3352052	●	●																					
	MT 2/ER32	3352053	●	●																					
	MT 4/M16	3352094				●			●	●															
	ISO 30	3352054																							
	ISO 40	3352056										●	●	●	●	●	●	●	●	●	●	●	●	●	●
Collet kit	ER 16	3440282		●																					
	ER 25	3441109	●	●																					
	ER 32	3441122				●	●	●	●	●	●	●	●	●	●	●	●	●	●	●	●	●	●	●	●
Collet chuck set	MT 2 direct	3351980	●	●																					
Vibration damper	SE 1	3381012	●	●	●	●	●	●	●	●															
	SE 2	3381016									○	○	○*	○*	○*	○*	○*	○*	○*	○*	○*	○*			
	SE 3	3381018																					○*	○*	
Try square 90	90°	3385052				●	●	●	●	●	●	●	●	●	●	●	●	●	●	●	●	●	●	●	●
Prism elbow	WP30	3352195	●	●	●	●	●	●	●	●	●	●	●	●	●	●	●	●	●	●	●	●	●	●	●
Levelling platen/ vibration damper	SE 55	3352981	●	●	●	●	●	●	●	●															
	SE 85	3352982									●	●	●	●	●	●	●								
Precision machine shoe	SEU1	3352985									V	●	●	●	●	●	●	●	●	●	●	●	●	●	●
Table feed	V 99	3352022				●	●	●																	
	V 250	3352029										●	●	●	●	●	●								
Tool clamping system	ISO 40	3352394														●	●								
Thread tapper	M5-M12	3352042	●	●	●	●	○	○	○	○	●	●	●	●	●	●	●	●	●	●	●	●	●	●	●
Workpiece support	WPS-1	3354261	●	●	●	●	●	●	●	●															
	WPS-2	3354262	●	●	●	●																			
	WPS-3	3354263				●	●	●	●	●															
	WPS-4	3354264					○	○	○	○	●	●	●												
T-slot nut	M8 -10 mm	3353020	●																						
	M10 -12 mm	3353022		●	●	●		●																	
	M12 -14 mm	3353025					●		●	●	●	●	●						●	●	●	●		●	●
	M14 -16 mm	3353026												●	●	●	●								
	M16 -18 mm	3353028										●											●	●	
Hold-down device	14 mm	3352031				●			●	●	●	●	●						●	●	●		●	●	
	18 mm	3352032						●														●	●	●	
Parallel spacer kit		3354001	●	●	●	●	●	●	●	●	●	●	●	●	●	●	●	●	●	●	●	●	●	●	●
Coolant pump	230 V	3352002	●	●	●	●	●	●																	
Coolant hose	KMS2	3356660	●	●	●	●	●	●																	
Coolant mist lubricator	MMC1	3356663	●	●	●	●	●	●																	
Starter set	BT 20	3353281		●																					
	BT 30	3353282				●		●																	
	BT 40	3353284						●			○	○	○	○	○	○	○	○	○	○	○	○	○	○	○
Base structures		3353000		●	●																				
		3353009				●																			
		3353014					●																		
		3353015						●																	

This equipment table covers all recommended equipment options. Depending on the individual case, use of accessories can be meaningful beyond this.

● Recommended ○ Recommended - restrictions apply

Rotary indexing tables

Horizontal-vertical rotary indexing tables

- › Quality rotary indexing tables made of premium cast meehanite
- › Precision bearing
- › Stability also under high load
- › Large spindle bore for clamping longer workpieces
- › Fast indexing via serrated locking plates for higher production speeds for mass-produced parts
- › Worm gear tempered and polished
- › Work table with 360° scale
- › 1 revolution of handwheel 4° rotation
- › Scale division on handwheel 2'
- › Indexing via handwheel with vernier scale possible
- › Up to 150 items (RT 150) and 400 items (RT 200) various indexing options possible with indirect indexing disks

Technical specifications		RT 100	RT 150	RT 200
Centring cone		MT 2	MT 2	MT 3
Transmission ratio		90:1	90:1	90:1
disc size	mm	110	150	200
Closed height x L x W	mm	72 x 138 x 118	79 x 204 x 156	104 x 265 x 199
Max. height	mm	80	102	133
Slot width/count	mm	11/3	11/3	16/3
Weight	kg	5	10	25

Horizontal-vertical rotary indexing table RT 100

Article no.

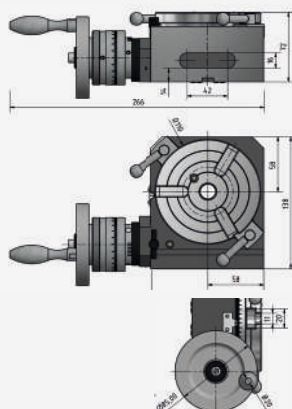

Rotary indexing table RT 100

- › 2 Clamping blocks
- › Centring cone MT 2

3356110

Three-jaw lathe chuck 75 mm

3356111

Tailstock Rst 1

Centre height 72 - 108 mm



3356155

Horizontal-vertical rotary indexing table RT 150

Article no.

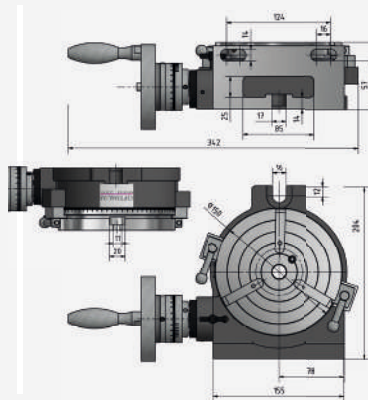

Rotary indexing table RT 150

- › 2 Clamping blocks
- › Centring cone MT 2

3356150

Chuck flange

3356154

Three-jaw lathe chuck Ø 130 mm centric

3356100

Indirect indexer IT 150

- › 3 Indexing disks
- › Sector arm
- › Angle shears with spring plate

3356152



Tailstock Rst 1

Max. height 72 - 108 mm



3356155

Horizontal-vertical rotary indexing table RT 200

Article no.

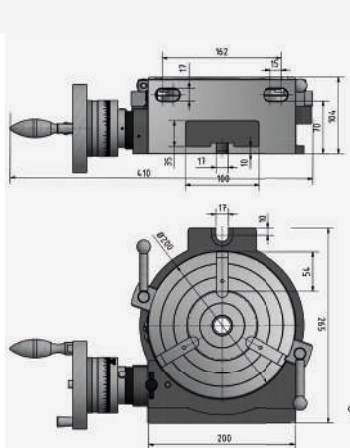

Rotary indexing table RT 200

- › 2 Clamping blocks
- › Centring cone MT 3

3356200

Chuck flange

3356254

Three-jaw lathe chuck 165 mm

3356225

Indirect indexer IT 200

- › 2 Indexing disks
- › Sector arm
- › Angle shears with spring plate

3356205



Tailstock Rst 2

› Max. height 110 - 145 mm



3356157

Horizontal-vertical rotary indexing table with 3-jaw chuck

- › Quality rotary indexing tables made of premium cast meehanite
- › Precision taper roller bearing
- › Stability also under high load
- › Large spindle bore for clamping longer workpieces
- › Direct indexing via serrated locking plates for higher production speeds for mass-produced parts
- › Degree indexing via 360° scale (RTE 165)
- › 7 serrated locking plates for 2/3/4/6/8/12/24x divisions (RTE 165)
- › Degree indexing via 360° scale with crank and vernier scale (RTU 165)
- › Direct indexing via serrated locking plate
- › 24 positions (15° indexing)
- › Three-jaw chuck
- › Including clamping disc with 3 grooves

Technical specifications		RTE 165	RTU 165
Table diameter	mm	165	165
Closed height x width x length	mm	200 x 260 x 218	221 x 250 x 235
Centre height	mm	130	130
Clamping disc	mm	203	203
Passageway	mm	36	36
Weight	kg	32.5	48

Technical specifications		RTE 165	RTU 165
Direct indexing disc		24x division (= 15°)	
Indirect indexing disc		2, 3, 4, 6, 8 and 12x division	
Indexing precision of direct indexer		45'	
Clamping options		Horizontal and vertical	
Workpiece mounting surface		With scale 360°	

Horizontal-vertical rotary indexing table RTE 165



- Rotary indexing table RTE 165**
- › 3-jaw chuck (mounted)
 - › Clamping disc
 - › Main indexing disk (24x division, mounted)
 - › 6 Indexing disks

Tailstock Rst 2
Max. height 110 - 145 mm

Article no.

3356365

3356157

Horizontal-vertical rotary indexing table RTU 165

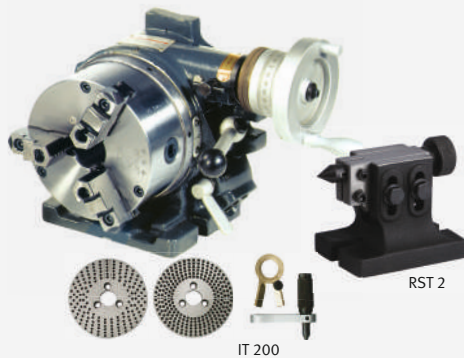

- Rotary indexing table RTU 165**
- › 3-jaw chuck (mounted)
 - › Clamping disc
 - › Main indexing disk (24x division, mounted)
 - › 6 Indexing disks
 - › Grips for handwheel

- Indirect indexer IT 200**
- › 3 Indexing disks
 - › Sector arm
 - › Angle shears with spring plate

Tailstock Rst 2
Max. height 110 - 145 mm 72 - 108 mm

Article no.

3354165

3356205

3356157

Universal dividing head TA 125

- › Swivels from -10° to +90°
- › Hardened and polished worm gear
- › Precision taper roller bearing
- › Hardened and polished main indexing disc (24x division), to index directly at 15°
- › Up to 300 indexing options possible with indirect indexing disks



- Scope of supply**
- › Tailstock Rst1 (peak height 72 - 108 mm)
 - › Centre point 60° / MT 2
 - › Lathe dog (tang)
 - › Chuck flange (Ø 140 mm, t = 12 mm) for carrier mounting a lathe chuck
 - › 3 pcs. Indirect indexing disc

Technical specifications	
Transmission	40:1
Closed height x width with centre x length	175 x 205 x 230 mm
Max. height	100 mm
Bore in mounting shaft (keyway)	18 mm
Slot width	16 mm
Direct indexing disc (Pitch)	15° / Ø 110 mm
Indirect indexing disc (Bore on reference circle)	15, 16, 17, 18, 19, 20, 21, 23, 27, 29, 31, 33, 37, 39, 41, 43, 47
Concentricity	0.015 mm
Weight	12 kg

3356125

Accessories for milling machines

End mill set HSS

- › Titanium coated
- › Improved hardness and stability with 2x to 5x service life
- › Twice the machining performance
- › Improved workpiece finish
- › Cylindrical shank and lateral lugs
- › Version with 2 cutting edges for milling keyways/fixing grooves and milling out the workpiece centre
- › Vertical or lateral milling possible
- › Version with 4 cutting edges and 30° right-hand twist for good chip removal in normal to hard materials

12-part 3352250

- › 6 end mills, short version · Version with 2 cutting edges.
DIN 1835 B (Ø12x73, Ø10 x 63, Ø8 x 61, Ø6 x 52, Ø5 x 52, Ø4 x 51 mm)
- › 6 end mills, short version · Version with 4 cutting edges.
DIN 1835 B (Ø12 x 83, Ø10 x 73, Ø8 x 61, Ø6 x 57, Ø5 x 57, Ø4 x 55 mm)

20-part 3352255

- › 10 end mills DIN 327 D · Short version · 2 cutting edges
DIN 1835 B, (3/4/5/6/8/10/12/14/18/20 mm)
- › 10 end mills DIN 844 B · Short version · 4 cutting edges
DIN 1835 B, (3/4/5/6/8/10/12/14/18/20 mm)

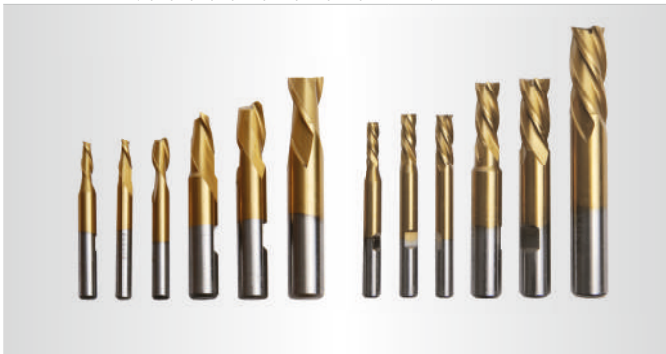

Carbide end mill set 3352118

- › **18-part**; 3 each in the sizes 3/4/6/8/10 and 12 mm
- › 4-cutting edge version
- › Coated solid carbide end mill (TiAlN)
- › Centre cut for plunging
- › Rake angle 35°



Radius end mill set 3352116

- › **9-part**; 3 each in the sizes 4 mm / 6 mm / 8 mm
- › 2-cutting edge version
- › Coated solid carbide end mill (TiAlN)
- › Face cutting geometry for plunging
- › Rake angle 30°

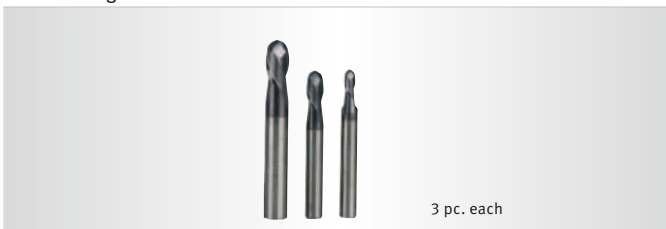

Twist drill HSS with morse taper

- › 9-part; sizes 14.5/16/18/20/22/24/26/28/30 mm
- › Long service life.
- › Good chip removal
- › Right handed

MT 2 3051002

MT 3 3051003



Assortment of clamping tools size

- › 58-part, in practical wall-mount holder
- › Metric thread
- › 24 pcs. pull studs
- › 6 pcs. T-slot nuts
- › 6 pcs. nuts
- › 4 pcs. extension nuts
- › 6 pcs. step blocks
- › 12 pcs. step blocks

Size 8 3352015

› T-slot nuts 10 mm; locking thread M 8

Size 10 3352016

› T-slot nuts 12 mm; locking thread M10

Size 12 3352017

› T-slot nuts 14 mm; locking thread M12

Size 14 3352018

› T-slot nuts 16 mm; locking thread M 14

Size 16 3352019

› T-slot nuts 18 mm; locking thread M16

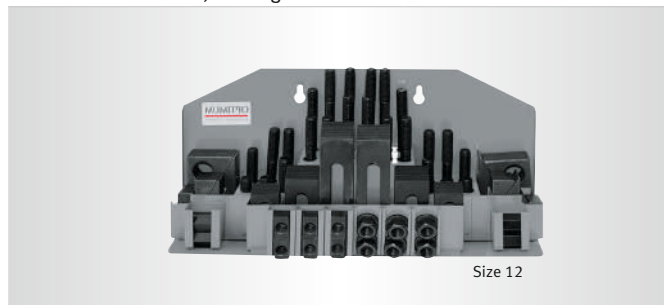

Edge sensor 3351171

- › Rotating spindle
- › Probe Ø 10 mm



Precision quick release chuck

Concentricity better than 0.06 mm

1 - 8 mm; B16	3050608
1 - 10 mm; B16	3050610
1 - 13 mm; B16	3050623
1 - 16 mm; B16	3050626
1 - 16 mm; B18	3050630



Arbor for drill chuck

External taper MT 2 / M10 / B16	3050670
External taper MT 3 / M12 / B16	3350303
External taper MT 4 / M16 / B16	3350304



Morse cone SK 50

3352067

B18 DIN2080

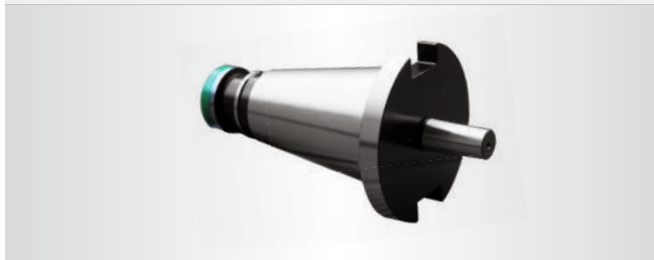

Arbor for drill chuck

External taper ISO 30 / M12 / B16	3352069
External taper ISO 40 / M16 / B16	3352070



OPTIMUM Direct quick release chuck

MT 2 1 - 16 mm; up to 6 000 rpm	3050571
MT 2 1 - 13 mm; up to 8 000 rpm	3050572
MT 3 1 - 16 mm; up to 6 000 rpm	3050573
MT 4 1 - 16 mm; up to 6 000 rpm	3050574



Milling head holder

SK 50	3352066
--------------	---------

› External taper \varnothing 27 mm DIN2080



Extension sleeves

MT 2 - MT 3	3050667
MT 3 - MT 4	3050668



Milling head holder

MT 2	3352102
-------------	---------

› External taper MT 2 / end mill holder \varnothing 16 mm



Reducing sleeve

MT 3 - MT 2 / M12	3350313
MT 4 - MT 3 / M16	3350314

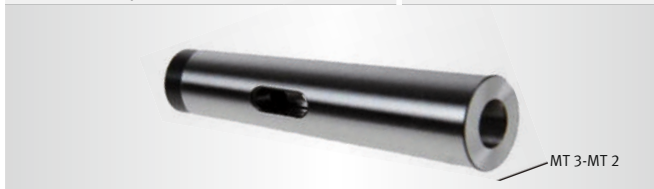

Adapter

ISO 30 / MT 3	3352068
BT 30 / MT 3	3536316



Accessories for milling machines

Copying and facing blade head

Univ. deployment in machining of all steels and NF metals
 For facing and copying
 Made of special steel - highly quenched 
 Excellent planarity and concentricity
 Milling body with asymmetrical division for extremely smooth action and uniform cutting
 Body and clamping shank form a unit for a short projection length and stable clamping
 No additional end mill mandrel used
 Special geometry for high-speed milling
 Economical as the platen can simply be rotated forward when the cutting edge is blunt (usable up to twelve times)
 Indexable inserts \varnothing 10 mm

Includes five turning plates RDET 1003 MOSN 8026	
Includes Torx TX15	
Tool holder shank BT 20	3350202
Tool holder shank BT 30	3350203
Pull stud BT 20	3352726
Pull stud BT 30	3536302
Tool holder shank MT 2/M10	3350212
Tool holder shank MT 3/M12	3350213
Tool holder shank ISO 30/DIN 2080	3350215

Outer diameter 52 mm
 ISO designation RD X 1003 D52/R5



Tool holder shank BT 40	3350204
Pull stud BT 40	3536332
Tool holder shank MT 4/M16	3350214
Tool holder shank ISO 40/DIN 2080	3350216

Outer diameter 63 mm
 ISO designation RD X 1003 D63/R5



HM indexing inserts 5 pcs.

> RDET 1003 MOSN8026 . Positive cutting geometry
 > PVD coated . For machining steel up to 900 N/mm², stainless steel, aluminium, non-ferrous metal, cast iron

RDET	3350220
-------------	---------

> RDHT 1003 MO-FA HF7 . Extremely positive cutting geometry, polished
 > For machining AL alloys, copper alloys, plastics

RDHT	3350221
-------------	---------

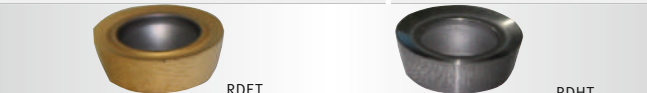

Precision bore head set

> 8 drill rods: BJ2008-32L/BJ2010-40L/BJ2014-53L/BJ2016-68L/BJ2020-83L/BJ2025-96L/BJ2030-115L/BJ20-L20-100L
 > Adjustment range 8 - 280 mm
 > Including drill rods, studs, circle extension, tools, case
 > Without indexable inserts

ISO 30/ER32 - M12/BT 30	3352127
ISO 40/ER32 - M16/BT40	3352128
ISO 50/ER32 - M24/BT50	3352129



Indexable insert set



Indexable insert set (10 pcs.)

for steel (for drill rod no. 8 and 7)	3352136
for aluminium (for drill rod no. 8 and 7)	3352141
for steel (for drill rod no. 6 and 5)	3352137
for aluminium (for drill rod no. 6 and 5)	3352142
for steel (for drill rod no. 4, 3, 2 and 1)	3352138
for aluminium (for drill rod no. 4, 3, 2 and 1)	3352143

Dimensions

Art. no.	ISO	D1	D2	S1	right
3352136	TPGT110304L-FY-EH10	11	3.4	3.18	0.4
3352141	TBGT060104L-W-T1200A	11	3.4	3.18	0.4
3352137	TPGT090204L-FY-EH10	9.6	2.8	2.38	0.4
3352142	TPGT090204L-W-T1200A	9.6	2.8	2.38	0.4
3352138	TBGT060104L-W-H1	6.9	2.2	1.59	0.4
3352143	TBGT060104L-W-T1200A	6.9	2.2	1.59	0.4

Cutting depth 0.2 - 0.6 - 1.0 mm

Feed 0.05 - 0.15 - 0.25 mm

Speed 100 - 250 - 400 mm

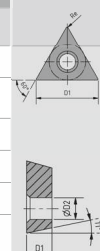

Cutterhead set

> For external and vertical machining
 > Adjustment range 10 - 220 mm
 > Includes boring cutter, shank, clamping sleeve; socket wrench

MT 3	3352083
MT 4	3352084



Collet chuck set

MT 2/ ER 25 - M10	3352052
› Collet chuck	
› 15 spring collets; sizes Ø 1.5 - Ø 16 mm/DIN ISO 15488	
› Hook wrench · Aluminium case	
MT 2/ ER 32 - M10	3352053
› Collet chuck	
› 18 spring collets; sizes Ø 2 - Ø 20 mm/DIN ISO 15488	
› Hook wrench · Aluminium case	
MT 3/ ER 32 - M12	3352093
› Collet chuck	
› 18 spring collets; sizes Ø 2 - Ø 20 mm/DIN ISO 15488	
› Hook wrench · Aluminium case	
MT 4/ ER 32 - M16	3352094
› Collet chuck	
› 18 spring collets; sizes Ø 2 - Ø 20 mm/DIN ISO 15488	
› Hook wrench · Aluminium case	
ISO 30/ER32 - M12/BT 30	3352054
› Collet chuck	
› 18 spring collets; sizes Ø 2 - Ø 20 mm/DIN ISO 15488	
› Pull stud M12/M12 and pull stud BT 30	
› Hook wrench · Aluminium case	
ISO 40/ER32 - M16/BT40	3352056
› Collet chuck	
› 18 spring collets; sizes Ø 2 - Ø 20 mm/DIN ISO 15488	
› Pull stud M16/M16 and pull stud BT 40	
› Hook wrench · Aluminium case	
ISO 50/ER32 - M24/BT50	3352065
› Collet chuck	
› 18 spring collets; sizes Ø 2 - Ø 20 mm/DIN ISO 15488	



ISO 40

Collet chuck ISO 30/ER25

3352046

› Hook wrench



ISO 30

Spring collet ER32 (individual)

Ø 6 mm	3441126
Ø 8 mm	3441128
Ø 10 mm	3441130
Ø 12 mm	3441132



Spring collet (individual)

› MT 3 direct-clamping / M12

Ø 4 mm	3352004
Ø 6 mm	3352006
Ø 8 mm	3352008
Ø 10 mm	3352010
Ø 12 mm	3352012
Ø 16 mm	3352013



Collet kit

MT 2 direct-clamping / M10 3351980

› 5-part; sizes Ø4 / Ø6 / Ø8 / Ø10 / Ø12 mm

MT 3 direct-clamping / M12 3352014

› 6-part; sizes Ø4 / Ø6 / Ø8 / Ø10 / Ø12 / Ø16 mm



MT 3

Collet kit

ER 16 3440282

› 12 spring collets; sizes Ø 1 - 10 mm

ER 25 3441109

› 15 spring collets; sizes Ø 1 - Ø 16 mm/DIN ISO 15488

ER 32 3441122

› 18 spring collets; sizes Ø 3 - Ø 20 mm/DIN ISO 15488



ER25

Accessories for milling machines

Vibration damping machine base

- › The machines and equipment can be installed without anchors and precisely levelled using the height adjustment system.
- › Effective impact and vibration damping improves the machine's capability

SE 1	3381012
SE 2	3381016
SE 3	3381018



Load	SE 1	SE 2	SE 3
Milling machines	340 kg	460 kg	1 600 kg
Sawing/gen. Machine	570 kg	1 460 kg	3 500 kg
Threading	M12	M16	M 20
Base Ø/Base height	120/32	160/35	185/39

Try square 90° 3385052

- › For clamping in case of mechanical processing of workpieces, checking and scribing work
- › Precision: Parallelism and trueness 0.01 to 100 mm
- › Lateral reinforcing ribs
- › Dimensions L x W x H: 202 x 126 x 150 mm . Weight 7 kg

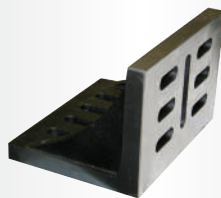

Universal compressed air tool clamping system

- › Includes tool clamp, cap, maintenance unit, gear rim, Draw-in rod, control box, operator control
- › High negative pressure achievable
- › Short change times through single-handed operation
- › Low eight thanks to optimised structure
- › Safe locking through toggle lever principle
- › Precise guiding thanks to optimised geometry
- › Low air consumption

ISO 40	3352394
--------	---------

- › For OPTImill MF 2V / MF 4V

Factory assembly clamping system 9000490



(Note: For orders without factory assembly: Some adjustment work may be necessary.)

NEW

Levelling platen/vibration damper

Article no.

- › Effective vibration and structure-borne noise insulation and noise reduction
- › Fast and technically uncomplicated levelling
- › Eliminates floor unevenness up to 5°
- › Precision levelling by means of a regular threaded screw



SE 55	3352981
-------	---------

- › Jackscrew M12 x 1 x 150
- › Maximum load: 600 kg

SE 85	3352982
-------	---------

- › Jackscrew M16 x 150
- › Maximum load: 1 500 kg

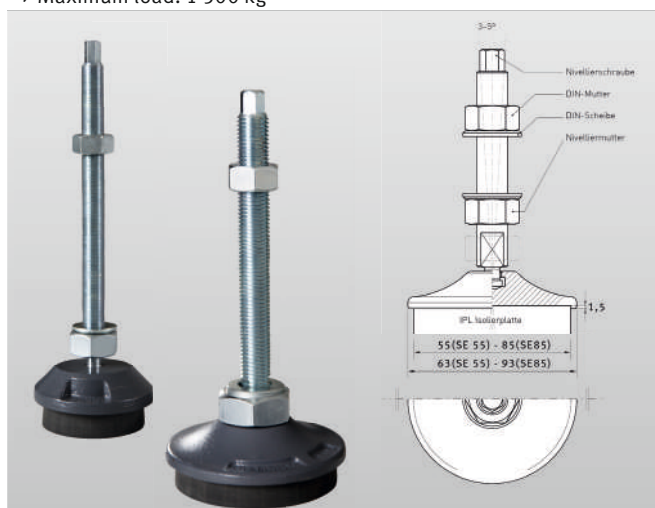

NEW

Precision machine shoe SEU1

3352985

- › Features vibration and structure-borne noise insulation
- › With slip-protection plate at top
- › Maximum load 60 kN
- › Suitable for M16 threaded rod
- › Vibration-insulation plate for particularly loads. Good structure-borne noise insulation
- › Adjustment range +5 / -4 mm
- › High-precision, jerk-free levelling even of heavy loads
- › Fast and precise installation even for heavy machines. Installation time savings of up to 50 % thanks to precision levelling and freedom of installation.
- › Improves the dynamic behaviour of machines while reducing noise
- › Weight 3.7 kg

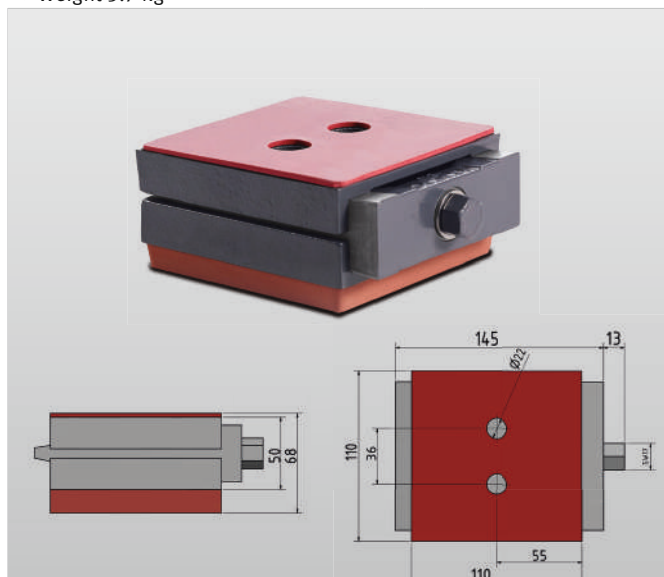

Universal milling table feed

- › Continuous speed control and rapid motion
- › Right-handed/left-handed rotation
- › 230 Volt, overload protection and end point switch
- › Motor: V99 - 90W, V250 - 130W
- › For self-assembly!

Milling table feed V 99	3352022
› Horizontal assembly	
Assembly kit MH 35 Vario X axis	3352035
Assembly kit MH 50 Vario X axis	3352036

Milling table feed V 250	3352029
---------------------------------	---------

- › Vertical assembly

Milling table feed V 250	3352025
---------------------------------	---------

- › For the Y axis MF 2V / MF 4V
- › Includes assembly kit



NEW

Workpiece support

- › Material S 45C

WPS-1 adjustment stroke 40 - 50 mm	3354261
WPS-2 adjustment stroke 65 - 90 mm	3354262
WPS-3 adjustment stroke 90 - 140 mm	3354263
WPS-4 adjustment stroke 140 - 230 mm	3354264

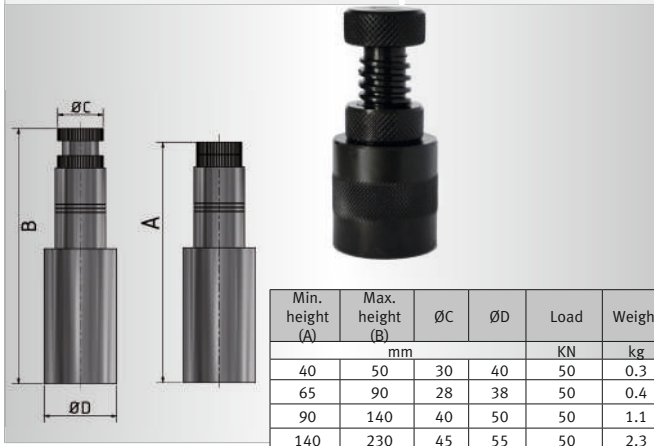

Prism WP 30

3352195

- › Robust design for use on tool machines.
- › High-precision design
- › Adjustable from 0° to 60° and from 0° to -30°
- › Tempered and ground carbon steel
- › Precision trueness 0.005 mm
- › Angle tolerance 0.01°
- › Dimensions L x W x H: 75 x 25 x 32 mm



Cross tables KT

- › Coolant channel
- › Dovetail guide adjustable
- › Adjustable handwheel scaling with 0.05 mm scale

KT 120	3356595
KT 179	3356596
KT 180	3356591
KT 210	3356600

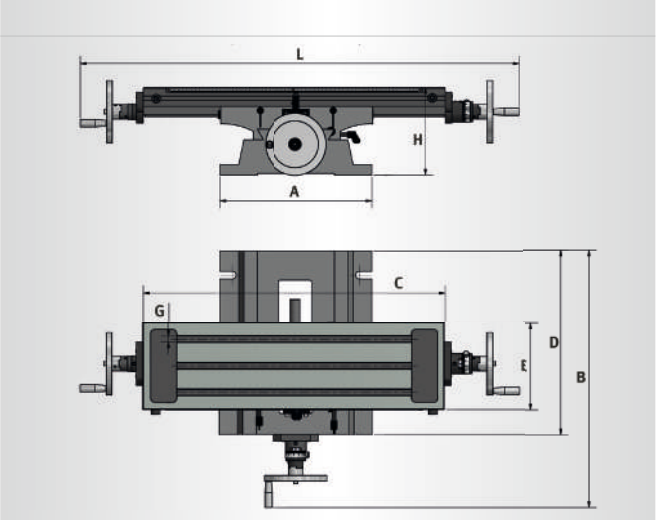

Technical specifications	KT 120	KT 179	KT 180	KT 210
A (Base width)	222 mm	274 mm	274 mm	370 mm
D (base length)	280 mm	340 mm	340 mm	445 mm
C (table length)	400 mm	500 mm	700 mm	730 mm
E (table width)	120 mm	180 mm	180 mm	210 mm
G (T-slot size)	10 mm	12 mm	12 mm	14 mm
L x W x H (mm)	506 x 400 x 140	748 x 483 x 155	948 x 483 x 155	1060 x 620 x 210
Weight	22 kg	46 kg	54 kg	84 kg
Travel				
X axis	220 mm	287 mm	480 mm	480 mm
Y axis	165 mm	167 mm	170 mm	210 mm
Max. load	40 kg	55 kg	55 kg	80 kg

Hold-down unit set of 2

- › Clamping height adjustable
- › Brass plate below the clamping arm protects material against damage

Table groove 14 mm/M12	3352031
› L x W x H: 115 x 42 x 39 mm Height adjustment: 0 - 89 mm	
Table groove 18 mm/M16	3352032
› L x W x H: 133 x 50 x 49 mm . Height adjustment: 0 - 101 mm	



Preface

Drilling

Milling Accessories

Turning

Saws

Grinding

Polishing

Lamps

Measuring

Accessories for milling machines

T-slot nut (individual)

M 8 / 10 mm	3353020
M10 / 12 mm	3353022
M12 / 14 mm	3353025
M 14 / 16 mm	3353026
M16 / 18 mm	3353028



Universal coolant unit

3352002

- › Connection 230V / 1 Ph
- › Max. delivery height 2.5 m / delivery rate 8 l/min
- › Tank content 11 l / dimensions L x W x H: 370 x 245 x 170 mm
- › Complete with tank, flexible tube, hose and switch/plug combination
- › Magnetic base fastener for coolant hose



Parallel shim set 18-part

3536191

- › For precision work for parallel mounting of workpieces in machines, vices on scoring boards or tool machines
- › Finely polished to 0.01 mm precision
- › Length 150 mm x width 8.5 mm
- › 2 pcs. each: 14 mm; 16 mm; 20 mm; 24 mm; 30 mm; 32 mm; 36 mm; 40 mm; 44 mm



Parallel shim set 20-part

3354001

- › For precision work for parallel mounting of workpieces in machines, vices on scoring boards or tool machines
- › Finely polished to 0.01 mm precision
- › Thickness 3 mm
- › Length 150 mm
- › 2 pcs. each: 8 mm; 13 mm; 16 mm; 19 mm; 22 mm; 25 mm; 31 mm; 35 mm; 38 mm; 41 mm



Thread tapping device M5 - M12/B16

3352042

- › Quick reverse built-in, immediately effective on changing the feed direction
- › Slip clutch 4-stage adjustable.

Scope of delivery:

- › Two flexible spring collets
- › Two open-ended spanners
- › Hand grip
- › Allen key



Technical specifications

Self-release path	4 mm
Freewheel	1.5 mm
Length compensation tensioned	8.5 mm
Max. speed	1 000 rpm
Transmission ratio forward and reverse	1 : 1.75
Cutting range	M5 - M12
Clamping range	3.5 - 10
Length	B16 DIN 238
Length compensation compressed	156 mm
Shank holder	5 mm

NEW

AQUACUT C1

3530030

- 10 litre cannister
- For mixing emulsions
- Drilling and cooling emulsion
- High-pressure resistant and containing mineral oil, for long tool life and clean surfaces
- Emulsifiable with water, microbe-resistant and kind to the skin



Coolant hose KMS 2

3356660

- › Two flexible and stable coolant hoses made of individual plastic elements
- › Not electrically conductive
- › Magnetic base holding force up to 50 kg
- › Length of coolant hoses each 335 mm
- › Insensitive to most solvents and chemicals
- › Universally deployable on all tool machines

Coolant mist lubricator MMC1

3356663

- › Magnetic base with a holding force of 75 kg
- › Base size L x W x H: 62 x 50 x 55 mm
- › Screw connection for external compressed air supply
- › Flexible and stable hose with a length of 500 mm



KMS 2



MMC1



Machine bases

Universal chassis and chip tray

- › for milling machine models MH 20V / MH 22V / VD
- › Chassis weight 28 kg
- › Chassis dimensions 420 x 340 x 800 mm
- › Chip tray dimensions 720 x 470 x 30 mm

Universal chassis	3353000
Chip tray	3352999



Dimensions

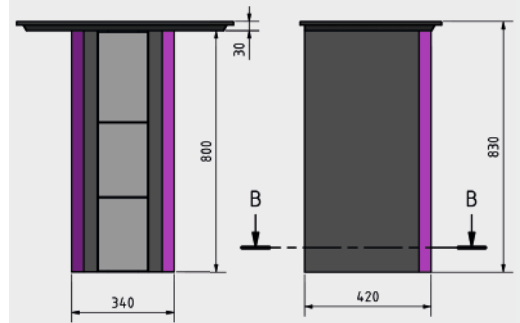

Preface

Drilling

Milling Accessories

Machine chassis

3353009

- › Solid design and weight ensure stability
- › For milling machine models MH 25V / MH 25SV
- › Weight 51 kg
- › Dimensions 500 x 700 x 750 mm



Dimensions

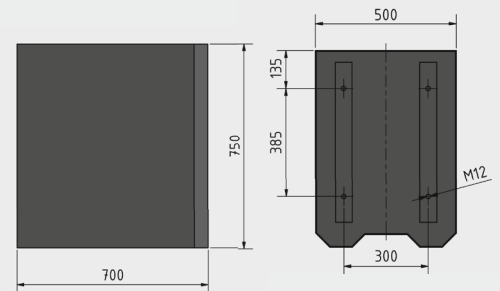

Turning

Machine chassis

3353014

- › Solid design and weight ensure stability
- › For milling machine models MH 35G / MB 4
- › Weight 76 kg
- › Dimensions 650 x 550 x 750 mm



Dimensions

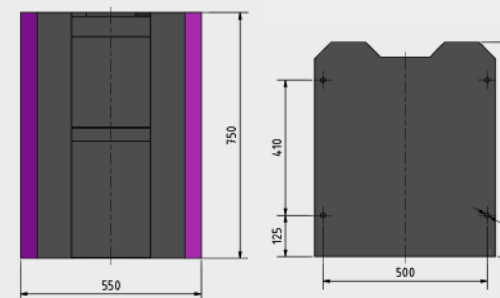

Saws

Grinding

Machine chassis

3353015

- › Solid design and weight ensure stability
- › For milling machine MH 50G / MH 50V
- › Weight 134 kg
- › Dimensions 650 x 550 x 750 mm



Dimensions

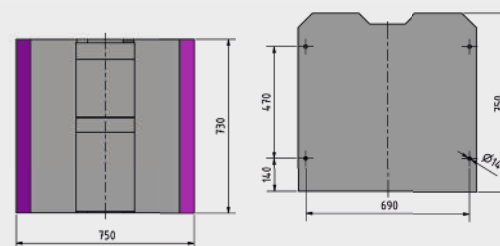

Polishing

Lamps

Measuring



BT 20

NEW

Starter set BT 20 3353281

Comprises:

- 1 pc. milling head holder Ø 16 mm
- 2 pcs. Weldon holder Ø 6 mm
- 2 pcs. Weldon holder Ø 8 mm
- 1 pcs. Weldon holder Ø 10 mm
- 1 pcs. Weldon holder Ø 12 mm
- 1 pc. tool fitting BT20/B16
- 11 pcs. pull studs
- 1 pc. quick-release drill chuck 1 - 13 mm
- 1 Facing and copying blade head
- 2 pcs. collet chuck ER 25
- 1 pc. spring collet spanner ER 25
- 12-part Collet kit ER 16

Milling head holder 3352728

> Collet Ø 16 mm



Weldon holder

Ø 6 mm	3352732
Ø 8 mm	3352734
Ø 10 mm	3352736
Ø 12 mm	3352738



Tool holder 3352727

> BT 20/B16



Pull stud 3352726

> Optimum custom build (no standard BT 20 bolts)



Precision quick release chuck

Concentricity better than 0.06 mm

1 - 8 mm; B16	3050608
1 - 10 mm; B16	3050610
1 - 13 mm; B16	3050623
1 - 16 mm; B16	3050626
1 - 16 mm; B18	3050630



Copying and facing blade head 3350202

Univ. deployment in machining of all steels and NF metals

For facing and copying

Made of special steel - highly quenched and tempered

Excellent planarity and concentricity

Includes Torx TX15

Outer diameter 52 mm

ISO designation RD X 1003 D52/R5



Fig. with optional pull stud

Collet chuck

ER 16	3352741
ER 25	3352744

NEW



Spring collet holder spanner

ER 16	3352742
ER 25	3352745

NEW



Collet kit ER 16 3440282

> 12 spring collets; sizes Ø 1 - 10 mm



Starter set BT 30 3353282

Comprises:

- 1 pc. milling head holder Ø 22 mm
- 1 pc. quick-release drill chuck 1 - 13 mm
- 2 pc. Weldon 6 mm
- 1 pc. Weldon 8 mm
- 1 pc. Weldon 10 mm
- 1 pc. Weldon 12 mm
- 1 pc. Weldon 16 mm
- 2 pc. Weldon 20 mm
- 1 pc. adapter BT 30 /MT 2
- 3 pcs. spring collet holder ER 32
- 1 pc. spring collet spanner ER 32
- 18-part Collet kit ER 32
- 1 pc. height adjuster
- 1 pc. assembly and tool adjustment gauge
- 14 pcs. pull studs
- 1 pc. taper squeegee

Milling head holder 3353306

› Collet Ø 22 mm



Chuck 3536303

› Clamping range 1 - 13 mm



Weldon holder

Ø 6 mm	3353310
Ø 8 mm	3353311
Ø 10 mm	3353312
Ø 12 mm	3353313
Ø 16 mm	3353314
Ø 20 mm	3353315



Adapter

› BT 30 to MT 2	3353305
› BT 30 to MT 3	3536316



Spring collet holder ER 32 3353304



Spring collet holder spanner ER 32 3353307



Height-adjuster 3536290

- › Analogue version
- › For fast and easy determination of the reference point on the Z axis and/or for adjusting tools "to zero" (e.g., for milling or drilling) without damaging the workpiece
- › Housing height 50 mm



Assembly and tool adjustment gauge 3536193

- › For easy and precise adjustment of tools
- › Vertical and horizontal collet for tools with a steep-angle taper

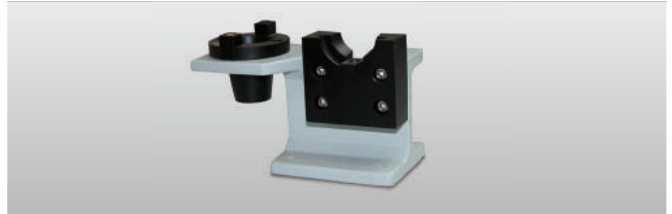

Taper squeegee 3353301



Pull stud

› BT 30 DIN 2080 M12	3353302
› BT 30 DIN 2080 M12/M12	3536177



Collet kit ER 32 3441122



Preface

Drilling

Milling Accessories

Turning

Saws

Grinding

Polishing

Lamps

Measuring

BT 40

Starter set BT 40 3353284

- Comprises:
- 1 pc. milling head holder Ø 27 mm
 - 1 pc. quick-release drill chuck 1 - 13 mm
 - 2 pc. Weldon 6 mm
 - 1 pc. Weldon 8 mm
 - 1 pc. Weldon 10 mm
 - 1 pc. Weldon 12 mm
 - 1 pc. Weldon 16 mm
 - 2 pc. Weldon 20 mm
 - 1 pc. adapter BT 40 /MT 3
 - 3 pcs. spring collet holder ER 32
 - 1 pc. spring collet spanner ER 32
 - 18-part Collet kit ER 32
 - 1 pc. height adjuster
 - 1 pc. assembly and tool adjustment gauge
 - 14 pcs. pull studs
 - 1 pc. taper squeegee

Milling head holder 3353336



Chuck 3353333



Weldon holder

Ø 6 mm	3353340
Ø 8 mm	3353341
Ø 10 mm	3353342
Ø 12 mm	3353343
Ø 16 mm	3353344
Ø 20 mm	3353345



Adapter 3353335



Spring collet holder ER 32 3353334



Spring collet holder spanner ER 32 3353307



Height-adjuster 33536290

- › Analogue version
- › For fast and easy determination of the reference point on the Z axis and/or for adjusting tools "to zero" (e.g., for milling or drilling) without damaging the workpiece
- › Housing height 50 mm



Assembly and tool adjustment gauge 33536194

- › For easy and precise adjustment of tools
- › Vertical and horizontal collet for tools with a steep-angle taper



Taper squeegee 3353331



Pull stud

- › BT 40 DIN 2080 M16 3353332
- › BT 40 DIN 2080 M16/M16 33536179



Collet kit ER 32 3441122





C

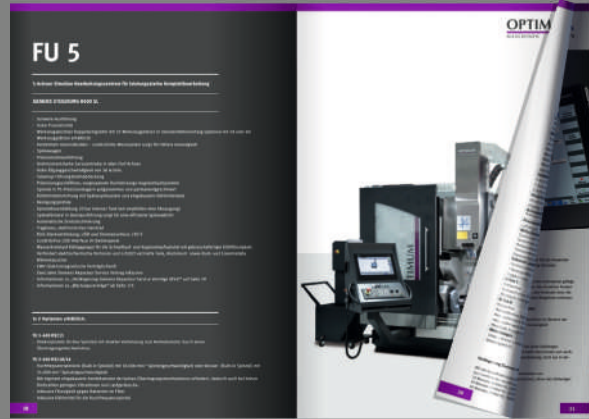

CNC Catalogue

To support any conceivable metalworking application, we have composed an assortment in our OPTIMUM CNC Catalogue that covers many areas with suitable machines. Request our free CNC catalogue, or download the catalogue from: www.optimum-maschinen.com



DISCOVER OUR PRODUCT VIDEOS NOW!





Are you familiar with our YouTube channel, **Optimum Machines**?

You can view all of our product videos here. We always seek to offer you a **wide range** and **high quality selection** of videos.

Subscribe to our YouTube channel, to avoid missing any of the new videos: www.youtube.com/user/OptimumMaschinen



SIEMENS SINAMICS G 120D Frequency inverters

Machines as per
standard EN
61800

DIN

Information on the Vario lathes

TH 4010V / TH 4210V / TH 4615V / TH 5620V / TZ4V

SINAMICS G120D

Brief overview of benefits

Highlights at a glance

Advanced safety function (STO, SLS)

STO - safe torque off as per EN 61800-5

SLS - Safely limited speed as per EN 61800-5

Recovery, low circuit feedback

Energy savings up to 20 %

No brake resistors required

Fast and easy diagnostic capability through LEDs

Standardised plug connections throughout

Rugged and flat design (IP65)

EMC class C1 as per EN 61800-3

Safety Integrated without encoder!

More direct switch-over

Faster braking

Resilient to high overload

The best possible single drive for high-performance solutions

The SINAMICS G120D impresses with its extremely flat design, an identical drill pattern for all versions, and the high degree of protection. The local frequency inverter offers safety functions that are unique in its class.

For example, its ability to provide line-commutated regeneration in generator operation removes the need for braking resistors. It thus makes a decisive contribution to saving energy. Of course it is also capable of communication.

The SINAMICS G120D sets new standards in local deployment. It has a modular design – consists of power modules and control unit – and covers a wide power range from 0.75 kW to 7.5 kW.



- ▶ A comprehensive safety package that helps to protect both persons and machines. And in an extremely efficient and economic way thanks to complete integration of the safety functions in the control and drive technology. In addition, it ensures safe and practical operation of your machine under all required operating conditions. The safety functions meet the requirements of DIN EN 61508 for use up to and including SIL (Safety Integrity Level) 2 and categories 3 and PL (Performance Level) d as per DIN EN ISO 13849.

The feature scope includes, for example:

- ▶ Functions for safe monitoring of speed and standstill
- ▶ Functions for establishing workspace and protected space boundaries, and for area detection
- ▶ Direct connection of all safety-related signals and their internal logical links

Siemens
SAFETY INTEGRATED



LATHES



Cast machine base

Page 137 - Page 159



Steel machine base

Page 160 - Page 175



Bench-top models

Page 176 - Page 177

Leading and feed spindle lathes, characterised by excellent flexibility, precision and economy.
With DPA 21 digital position display and quick change tool holder.

Facts that impress in terms of quality, performance and price

- ▶ Tempered and polished z-axis guideway
- ▶ Spindle collet Camlock DIN ISO 702-2 no. 8
- ▶ Precision slide
- ▶ All guides adjustable using cleats
- ▶ Adjustment range top slide $\pm 90^\circ$
- ▶ Guaranteed concentricity of spindle nose better than 0.015 mm
- ▶ Shafts, gears and main spindle run in oil bath
- ▶ Gearwheels smooth running, tempered and ground borne on 2 re-adjustable precision taper rollers
- ▶ Clear-cut selector lever for switching the feed speeds
- ▶ Closed design of the quick shift feed gear
- ▶ Gears and shafts tempered and ground, running in oil bath on precision bearings
- ▶ Hand wheels decoupled and approved in line with EN 23125
- ▶ Two-channel CW/CCW switch approved in line with EN 23125
- ▶ Switch with lifecycle calculation, approved in line with EN ISO 13849
- ▶ Right-handed/left-handed rotation switchable on bed slide, switchable via switching spindle
- ▶ Central lubrication in bed slide
- ▶ Coolant system featuring separate coolant tank, fill level display and oil trap; easy and complete draining and cleaning as per DIN
- ▶ Leading spindle cover
- ▶ emergency stop button, motor circuit breaker, lockable main switch
- ▶ Emergency stop device with foot pedal

- ▶ Safety hand wheels with release function in the X axis
- ▶ Hand wheels with adjustable fine scaling 0.04 / 0.02 mm
- ▶ Tailstock adjustable ± 10 mm for turning spheres
- ▶ Tailstock spindle sleeve and hand wheel with adjustable fine scaling
- ▶ Tailstock crank for position change
- ▶ Tailstock spindle sleeve with two adjustable transmission ratios 1/4 or 1/1 rev
- ▶ LED machine lamp
- ▶ Fast feed - Pushbutton and selector lever for enabling rapid motion in transverse and longitudinal directions for an even more rational work approach. Does not switch off the entire machine when running into the limit switch
- ▶ Safety limit switch with positively opening contacts
- ▶ Electrical motor brake with fast emergency stop – in normal operations, fast stop without post-run
- ▶ Electrical system with Siemens components
- ▶ Energy chain for material-friendly cable and hose guiding
- ▶ Quick change tool holder SWH 9-D
- ▶ 1 tool holder 41 x 180 type D for square chisels 32 mm

Digital position display DPA 21

- › Clear reduction of manufacturing times
- › Glass scales

Control Cabinet

- › 24 Volt DC Power Supply
- › All contactors und relays by Siemens or Schneider

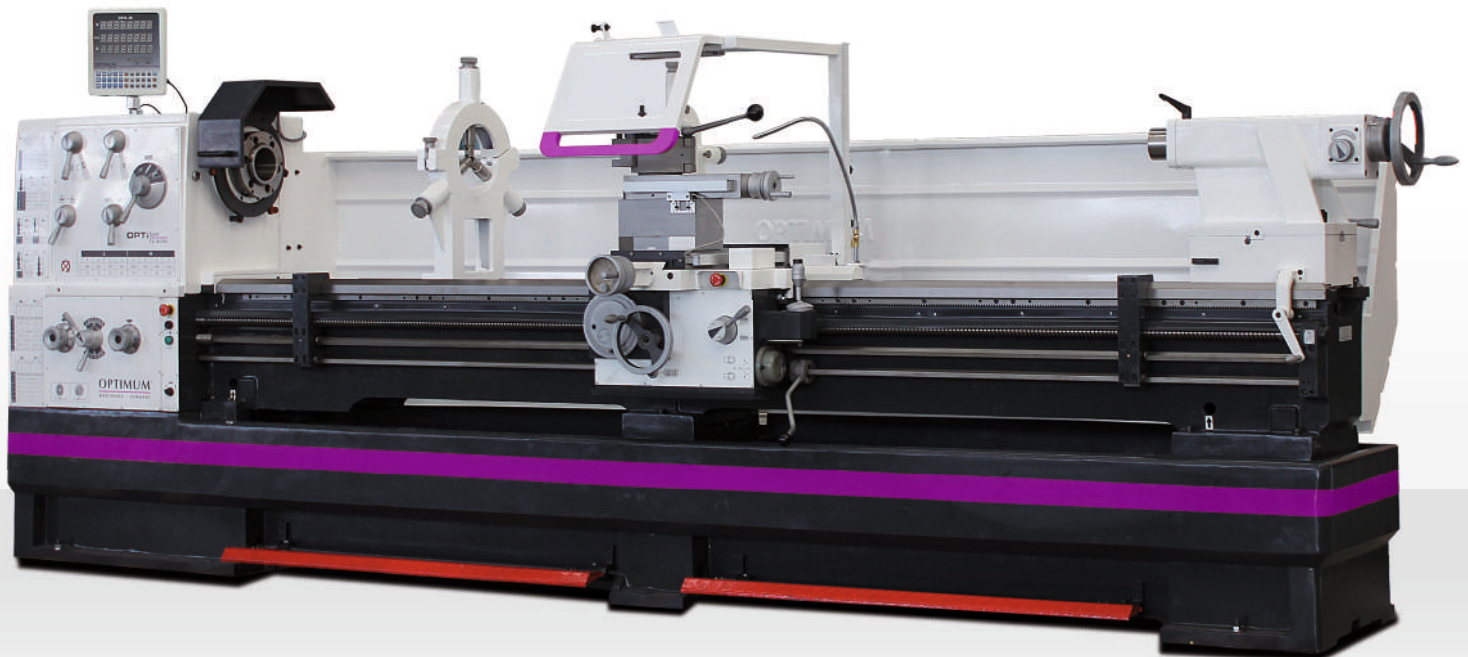
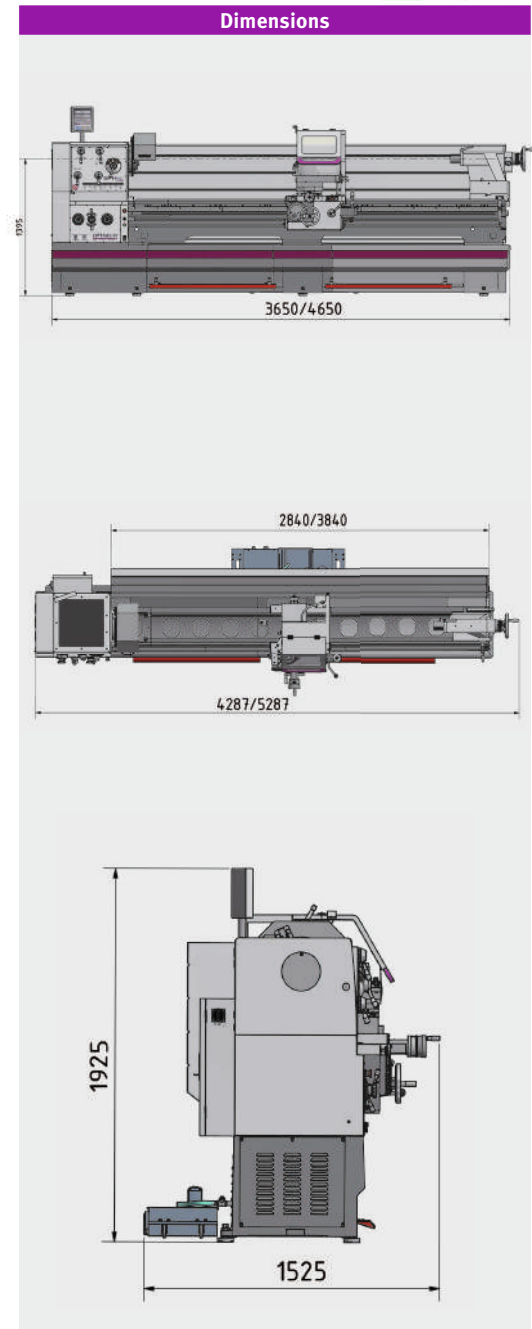

Fig.: TH 8030D

Technical specifications, accessories and dimensions

Model	TH 8020D	TH 8030D
Article no.	3462230	3462240
Technical specifications		
Electrical connection	400 V / 3 Ph ~50 Hz	
Total rated value	12 kW	
Coolant pump motor	150 W	
Spindle		
Drive motor	11 kW	
Spindle taper	Ø 113 mm (taper 1:20)	
Spindle seat	Camlock DIN ISO 702-2 No. 8	
Spindle bore, bar passage diameter	Ø 105 mm	
Quick change tool holder height	SWH 9-D	
Work area		
Centre height	400 mm	
Centre width	2 050 mm	3 050 mm
Swing Ø over machine bed	800 mm	
Swing in the bed bridge	1 035 mm	
Turning length in bed bridge	250 mm	
Swing over cross slide	570 mm	
Bed width	400 mm	
Load bearing capacity	1.4 t/m	
Speed range		
Spindle speed	25 - 1 600 rpm	
Number of speeds	16 speeds	
Travel		
Top slide travel	230 mm	
Cross slide travel	368 mm	
Feeds and pitches		
Feed motor output	550 W	
Rapid traverse	3.8 m /min. max. 5 min. (30 min. break)	
Longitudinal feed within the range	0.044 - 1.48 mm/rev (25 feeds)	
Cross feed within	0.022 - 0.74 mm/rev (25 feeds)	
Pitch - metric in range	0.45 - 120 mm/rev (54 pitches)	
Pitch - inch in range	80 - 7/16 turns/inch (60 pitches)	
Diametral pitch in range	7/8 - 160 turns/π (42 pitch)	
Modular thread in range	0.25 - 60 mm x π (46 thread)	
Tailstock		
Tailstock seat	MT 5	
Tailstock quill diameter/stroke	90 mm/235 mm	
Dimensions		
Length	4 287 mm	5 287 mm
width x height	1 525 x 1 925 mm	
Weight	3 455 kg	3 820 kg

Lathe chuck	Art no.
OPTIMUM three-jaw lathe chuck Ø 315 mm no. 8, centric	3442768
OPTIMUM Four-jaw lathe chuck Ø 315 mm no. 8, centric	3442856
OPTIMUM Four-jaw lathe chuck Ø 315 mm no. 8, individual	3442888
BISON three-jaw lathe chuck Ø 315 mm no. 8, centric	3450335
BISON Four-jaw lathe chuck Ø 315 mm no. 8, centric	3450385
Accessories	Art no.
Travelling centre MT 5	3440705
BISON co-travelling centre MT 5 (2-row SKF angular contact bearings)	3451005
Lathe tool set HM 25 mm, 5-part (see page 188)	3441672
Lathe tool set HM 25 mm, 5-part, extension kit (see page 188)	3441623
Vibration-damping machine base SE 3 (6 pcs. required)	3381018
Vibration damper SE 85 (6 pcs. needed)	3352982
› More accessories for lathes from page 180	



Remember to order a lathe chuck

Scope of supply

- › Steady rest passageway max. Ø 150 mm
- › Follow rest passageway max. Ø 130 mm
- › LED machine lamp
- › Reduction sleeve Ø 113 mm / MT 5
- › One fixed and one alloyed centre MT 5
- › Quick change tool holder 9-D
- › Tool holder 41 x 180 type D for square chisels 32 mm
- › Replaceable gear set
- › Quality oil included
- › Operating tool

Leading and feed spindle lathes, characterised by excellent flexibility, precision and economy.
With DPA 21 digital position display and quick change tool holder.

Facts that impress in terms of quality, performance and price

- ▶ Tempered and polished z-axis guideway
- ▶ Spindle collet Camlock DIN ISO 702-2 no. 8
- ▶ Precision slide
- ▶ Hand wheels with adjustable fine scaling 0.04 / 0.02 mm
- ▶ All guides adjustable using cleats
- ▶ Gears and shafts running in oil bath
- ▶ Adjustment range top slide $\pm 90^\circ$
- ▶ Guaranteed concentricity of spindle nose better than 0.015 mm
- ▶ Main spindle runs in oil bath
- ▶ Gearwheels smooth running, tempered and ground borne on 2 re-adjustable precision taper rollers
- ▶ Clear-cut selector lever for switching the feed speeds
- ▶ Closed design of the quick shift feed gear
- ▶ Gears and shafts tempered and ground, running in oil bath on precision bearings
- ▶ Hand wheels decoupled and approved in line with EN 23125
- ▶ Two-channel CW/CCW switch approved in line with EN 23125
- ▶ Switch with lifecycle calculation, approved in line with EN ISO 13849
- ▶ Right-handed/left-handed rotation switchable on bed slide, switchable via switching spindle
- ▶ Central lubrication in bed slide
- ▶ Coolant system featuring separate coolant tank, fill level display and oil trap; easy and complete draining and cleaning as per DIN
- ▶ Leading spindle cover

- ▶ Emergency stop button, motor circuit breaker, lockable main switch
- ▶ Emergency stop device with foot pedal
- ▶ Safety hand wheels with release function in the X axis
- ▶ Tailstock adjustable ± 10 mm for turning spheres
- ▶ Tailstock spindle sleeve and hand wheel with adjustable fine scaling
- ▶ Tailstock crank for position change
- ▶ Tailstock spindle sleeve with two adjustable transmission ratios 1/4 or 1/1 rev
- ▶ LED machine lamp
- ▶ Fast feed - Pushbutton and selector lever for enabling rapid motion in transverse and longitudinal directions for an even more rational work approach. Does not switch off the entire machine when running into the limit switch
- ▶ Safety limit switch with positively opening contacts
- ▶ Electrical motor brake with fast emergency stop – in normal operations, fast stop without post-run
- ▶ Electrical system with Siemens components
- ▶ Energy chain for material-friendly cable and hose guiding
- ▶ Quick change tool holder SWH 9-D
- ▶ 1 tool holder 41 x 180 type D for square chisels 32 mm

Digital position display DPA 21

- › Clear reduction of manufacturing times
- › Glass scales



Control Cabinet

- › 24 Volt DC Power Supply
- › All contactors und relays by Siemens or Schneider



Fig.: TH 6630D

Technical specifications, accessories and dimensions

Model	TH 6620D	TH 6630D
Article no.	3462210	3462220
Technical specifications		
Electrical connection	400 V / 3 Ph ~50 Hz	
Total rated value	10 kW	
Coolant pump motor	150 W	
Spindle		
Drive motor	9 kW	
Spindle taper	Ø 113 mm (taper 1:20)	
Spindle seat	Camlock DIN ISO 702-2 No. 8	
Spindle bore, bar passage diameter	Ø 105 mm	
Quick change tool holder	SWH 9-D	
Work area		
Centre height	330 mm	
Centre width	2 050 mm	3 050 mm
Swing Ø over machine bed	660 mm	
Swing in the bed bridge	900 mm	
Turning length in bed bridge	250 mm	
Swing over cross slide	440 mm	
Bed width	400 mm	
Load bearing capacity	1.4 t/m	1.4 t/m
Speed range		
Spindle speed	25 - 1 600 rpm	
Number of speeds	16 speeds	
Travel		
Top slide travel	230 mm	
Cross slide travel	368 mm	
Feeds and pitches		
Feed motor output	550 W	
Rapid traverse	3.8 m /min. max. 5 min. (30 min. break)	
Longitudinal feed within the range	0.044 - 1.48 mm/rev (25 feeds)	
Cross feed within	0.022 - 0.74 mm/rev (25 feeds)	
Pitch - metric in range	0.45 - 120 mm/rev (54 pitches)	
Pitch - inch in range	80 - 7/16 turns/inch (60 pitches)	
Diametral pitch in range	7/8 - 160 turns/π (42 pitch)	
Modular thread in range	0.25 - 60 mm x π (46 thread)	
Tailstock		
Tailstock seat	MT 5	
Tailstock quill diameter/stroke	90 mm/235 mm	
Dimensions		
Length	3 650 mm	4 650 mm
width x height	1 500 x 1 785 mm	
Weight	3,345 kg	3 730 kg

Lathe chuck	Art no.
OPTIMUM three-jaw lathe chuck Ø 315 mm no. 8, centric	3442768
OPTIMUM Four-jaw lathe chuck Ø 315 mm no. 8, centric	3442856
OPTIMUM Four-jaw lathe chuck Ø 315 mm no. 8, individual	3442888
BISON three-jaw lathe chuck Ø 315 mm no. 8, centric	3450335
BISON Four-jaw lathe chuck Ø 315 mm no. 8, centric	3450385
Accessories	Art no.
Travelling centre MT 5	3440705
BISON co-travelling centre MT 5 (2-row SKF angular contact bearings)	3451005
Lathe tool set HM 25 mm, 5-part (see page 188)	3441672
Lathe tool set HM 25 mm, 5-part, extension kit (see page 188)	3441623
Vibration-damping machine base SE 3 (6 pcs. required)	3381018
Vibration damper SE 85 (6 pcs. needed)	3352982
› More accessories for lathes from page 180	

*Important information on transport surcharges and „General notes on operating our machines“ on page 249

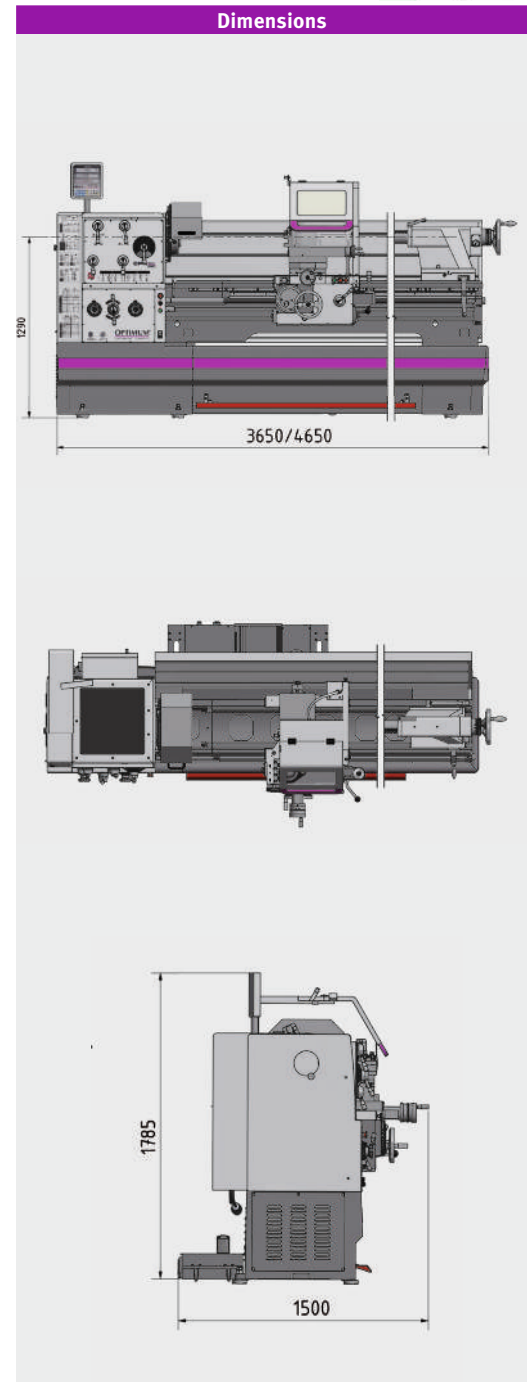

Remember to order a lathe chuck

Scope of supply

- › Steady rest passageway max. Ø 150 mm
- › Follow rest passageway max. Ø 130 mm
- › LED machine lamp
- › Reduction sleeve Ø 113 mm / MT 5
- › One fixed and one alloyed centre MT 5
- › Quick change tool holder 9-D
- › Tool holder 41 x 180 type D for square chisels 32 mm
- › Replaceable gear set
- › Quality oil included
- › Operating tool

Preface

Drilling

Milling

Turning

Saws

Grinding

Polishing

Lamps

Measuring

Precision feed and lead spindle lathes comply with strictest requirements in terms of technical equipment and precision. With digital position display **NEWALL** DP 700

Facts that impress in terms of quality, performance and price

- ▶ Machine bed and chassis made heavily ribbed cast material
- ▶ Single-part steel machine chassis
- ▶ High degrees of rigidity of the spindle bar housing thanks to pronounced ribbing made of 25GG cast material
- ▶ All feed gearwheels made of steel, hardened and polished
- ▶ shafts on needle bearings, all components lubricated in oil bath
- ▶ Hardened and polished spindle guarantees high degrees of accuracy and durability
- ▶ The powerful machining performance means that a high level of chip removal during roughing work is no problem
- ▶ Easy to service thanks to removable rear panel
- ▶ Energy chain for material-friendly cable and hose guiding
- ▶ Lockable chip guard moves with the bed slide with integrated position indicator and coolant hose, manually adjustable
- ▶ Decoupled hand wheels approved in line with EN 23125
- ▶ Two-channel CW/CCW switch approved in line with EN 23125
- ▶ No interchangeable gears required
- ▶ Switch with lifecycle calculation, approved in line with EN ISO 13849
- ▶ With safety device to prevent simultaneous operation of thread cutting and pitch mechanism
- ▶ Hardened and polished bed guides

- ▶ Electronically braked motor
- ▶ Electronic feed shut-off of Z axis
- ▶ All electronic controls centrally accessible
- ▶ Working area completely illuminated
- ▶ External coolant tank with filling level display and oil separator
- ▶ Complete feed and lead spindle cover
- ▶ Electrical position shut-off with quadruple positioning stop
- ▶ Three-jaw lathe chuck included in standard scope of delivery
- ▶ Quick change tool holder SWH 7-C
- ▶ Tool holder 32 x 130 type D for square chisels 25 mm

▶ Digital position display DP700

(For more information, see „NEWALL - DP700“ on page 244)

TX 5216:

Large spindle bore \varnothing 80 mm

TX 6222:

Large spindle bore \varnothing 105 mm

Control Cabinet

- > 24 Volt DC Power Supply
- > All contactors und relays by Siemens or Schneider



Centralised, user-friendly operation on touch panel



- > Pitch deactivation using button
- > Feed bar drive
- > Rapid motion X and Y axis
- > Machine lamp
- > Cooling agent

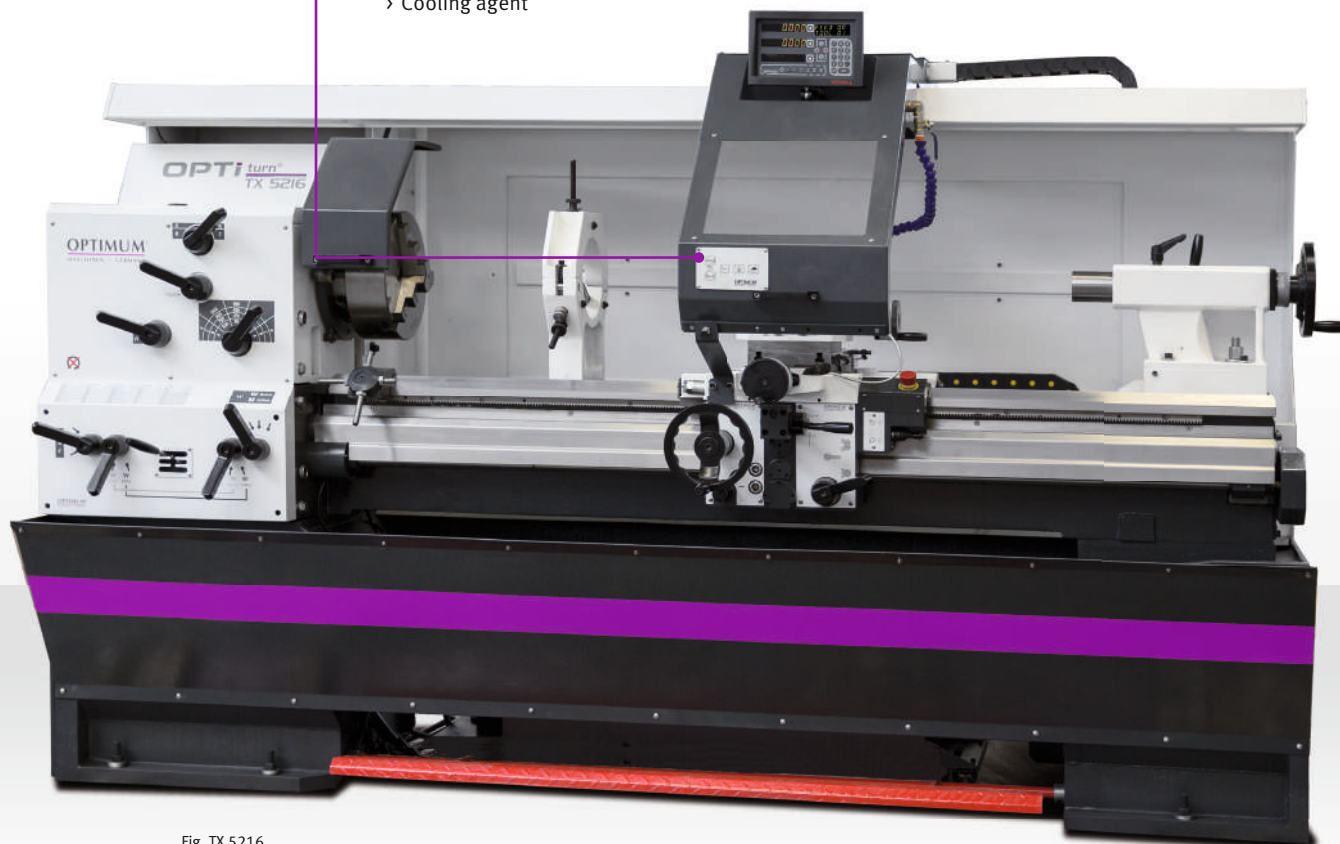
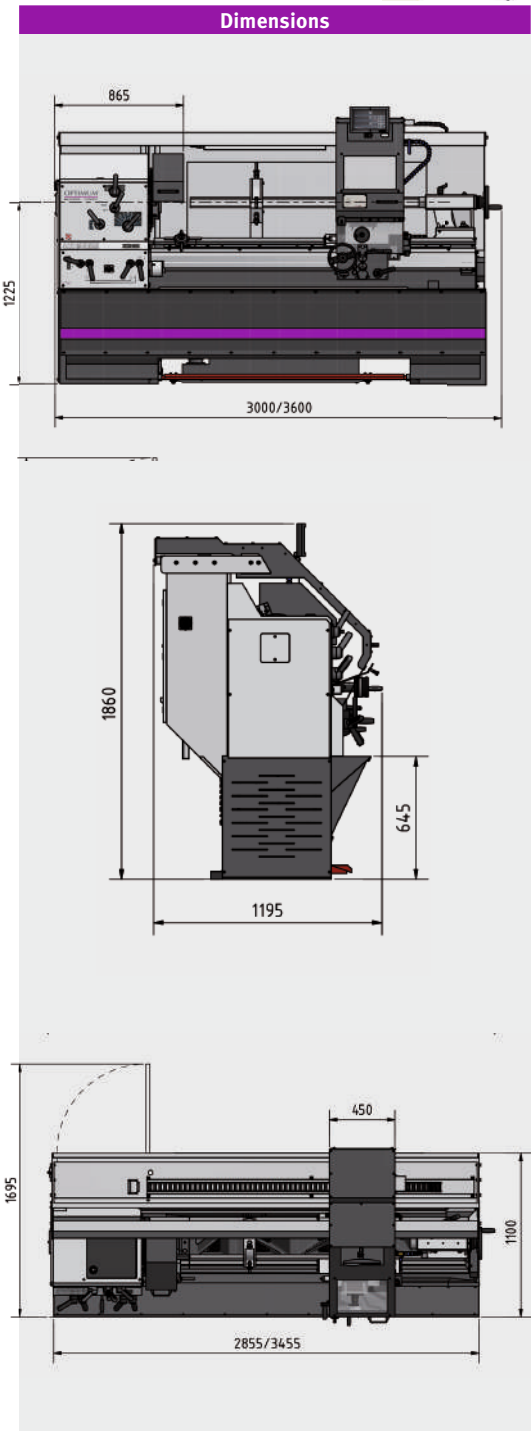

Fig. TX 5216

Technical specifications, accessories and dimensions

Model	TX 5216	TX6222
Article no.	3432440	3432460
Technical specifications		
Electrical connection	400 V / 3 Ph ~50 Hz	
Total rated value	6.1 kW	8.5 kW
Coolant pump motor	100 W	
Spindle		
Drive motor	5.5 kW	7.5 kW
Spindle taper	MT 7	Ø 113 mm (taper 1:20)
Spindle seat	Camlock DIN ISO 702-2 No. 8	
Spindle bore, bar passage diameter	Ø 80 mm	Ø 105 mm
Quick change tool holder	SWH 7-C	
Technical specifications		
Centre height	260 mm	310 mm
Centre width	1 600 mm	2 220 mm
Swing Ø over machine bed	520 mm	620 mm
Swing over cross slide	324 mm	424 mm
Bed width	350 mm	
Speed range		
Spindle speed	30 - 1 500 rpm	40 - 1 650 rpm
Number of speeds	12 speeds	
Travel		
Top slide travel	170 mm	
Cross slide travel	350 mm	
Feeds and pitches		
Longitudinal feed within the range	0.05 - 1.5 mm/rev (55 feeds)	
Cross feed within	0.025 - 0.75 mm/rev (55 feeds)	
Metric pitch	0.5 - 15 mm/rev (55 pitches)	
Pitch - inch in range	60 - 2 turns/inch (55 pitches)	
Diametral pitch in range	7/8 - 160 Gg/π (42 gears)	
Modular thread in range	0.25 - 7.5 mm x π (55 thread)	
Tailstock		
Tailstock seat	MT 5	
Tailstock quill diameter/stroke	Ø 72 mm/ 180 mm	
Dimensions		
Length	3 000 mm	3 600 mm
width x height	1 195 x 1 860 mm	1 194 x 1 860 mm
Weight	2 470 kg	2 800 kg

Accessories	Art no.
TX5216	
Follow rest passageway 15 - 125 mm	3438020
Steady rest passageway 10 - 185 mm	3438023
Steady rest passageway 160 - 285 mm	3438024
Lathe tool set HM 20 mm (see as of Page 188)	3441670
Lathe tool set HM 20 mm, extension kit (see page 188)	3441617
TX6222	
Follow rest passageway 15 - 125 mm	3438030
Steady rest passageway 10 - 185 mm	3438033
Steady rest passageway 160 - 285 mm	3438034
Lathe tool set HM 25 mm, extension kit (see page 188)	3441672
Lathe tool set HM 25 mm (see page 188)	3441623
Accessories	
Clamping disc Ø 450 mm no. 8	3442982
Travelling centre MT 5	3440705
BISON co-travelling centre MT 5	3451005
Vibration damping machine base SE 3 (6 pcs. required)	3381018
› More accessories for lathes from page 180	



Scope of supply

- › Three-jaw lathe chuck Ø 315 mm no. 8
- › Fixed centre MT 5 long
- › Fixed centre MT 5 short
- › Operating tool
- › Machine initially filled with premium grade oil
- › Quick change tool holder SWH 7-C
- › Tool holder for square chisels 32 x 130 type D for 25 mm square chisels

TX 5216:

- › Reduction sleeve MT 7 / MT 5

TX 6222:

- › Reduction sleeve Ø 113 mm/MT 5

Precision feed and lead spindle lathes with digital position display NEWALL DP 700 and quick change tool holder. TZ 4V with electronically controlled drive

Facts that impress in terms of quality, performance and price

- ▶ Tempered and polished z-axis guideway
- ▶ Partly clad with travelling, generously dimensioned chip guard
- ▶ Travelling swarf guard with integrated position display, coolant hose and additional control panel
- ▶ Plane and top slide spindle tempered and ground, adjustable via split spindle nut
- ▶ Feed and lead screw cover
- ▶ Granular feed and tapping range
- ▶ LED machine light for complete elimination of the workspace
- ▶ Energy chain for material-friendly cable and hose guiding
- ▶ Replacement gears also optionally available for imperial and modular thread
- ▶ Control cabinet with 24-V DC adapter
- ▶ Switch with lifecycle calculation, approved in line with EN ISO 13849
- ▶ Decoupled hand wheels approved in line with EN 23125
- ▶ Two-channel CW/CCW switch approved in line with EN 23125

- ▶ All contactors und relays by Siemens or Schneider
- ▶ Safety hand wheels with release function in the X and Z axis
- ▶ Chip tray pulls out to front
- ▶ Quick change tool holder SWH 5-B
- ▶ Tool holder 25 x 120 type D for square chisels 20 mm
- ▶ **Digital position display NEWALL DP 700**

TZ 4:

- ▶ Reduction of the main spindle braking time thanks to electrically braked motor
- ▶ Motor circuit switch

TZ 4V

- ▶ Reduction of the main spindle braking time thanks to energy recuperation
- ▶ All contactors und relays by Siemens or Eaton

Control panel

For switching

- › Lighting
- › Coolant for TZ 4 for shifting two-speed motor
- › Foil keypad, easily cleanable



TZ 4V:

Inverter SINAMICS G120D



More information: „SIEMENS SINAMICS G 120D Frequency inverters“ on page 136

Bed geometry

- › Flat angle
- › Higher force absorption



Fig.: TZ 4 - Shown with optional lathe chuck

Technical specifications, accessories and dimensions

Model	TZ 4	TZ 4V**
Article no.	3432240	3432245
Technical specifications		
Electrical connection	400 V / 3 Ph ~50 Hz	
Total rated value	5 kW	6 kW
Coolant pump motor	125 Watts	
Spindle		
Drive motor	3 kW/4.5 kW	5.5 kW
Spindle taper	MT 6	
Spindle seat	DIN ISO 702-1 No. 5	
Spindle bore, bar passage diameter	Ø 52 mm	
Quick change tool holder	SWH 5-B	
Technical specifications		
Centre height	200 mm	
Centre width	800 mm	
Swing Ø over machine bed	400 mm	
Swing over cross slide	245 mm	
Bed width	260 mm	
Speed range		
Spindle speed	45 - 1 800 rpm	50 - 3 000 rpm
Number of speeds	16 speeds	2 speeds. Electrically controlled
Travel		
Top slide travel	112 mm	
Cross slide travel	212 mm	
Feeds and pitches		
Longitudinal feed within the range	0.0263 - 1.8416 mm/rev (48 feeds)	
Cross feed within	0.0133 - 0.9321 mm/rev (48 feeds)	
Pitch - metric in range	0.2 - 14 mm/rev (26 pitches)	
Pitch - inch in range (Replaceable gear set accessory art. no. 3444160)	80 - 1 turns/inch (42 pitch)	
Modular thread in range	0.1 - 7 mm x π (44 thread)	
Diametral pitch in range (Replaceable gear set accessory art. no. 3444160)	3 - 200 turns/π (33 pitch)	
Tailstock		
Tailstock seat	MT 3	
Spindle sleeve diameter / stroke	Ø 50 mm / 110 mm	
Dimensions		
Length x width x height	1 960 x 1 060 x 1 690 mm	
Weight	1 250 kg	

Lathe chuck TZ 4	Article no.
BISON four-jaw lathe chuck Ø 250 mm no. 5 cast Centrally clamping (chuck flange 3450218 required)	3450216
Lathe chuck TZ 4V	Article no.
BISON four-jaw lathe chuck Ø 250 mm no. 5 steel Centrally clamping (chuck flange 3450218 required)	3450217
Lathe chucks and accessories	Article no.
Chuck flange for lathe chuck Ø 250 mm no. 5 (for lathe chuck 3450216/3450217)	3450218
BISON three-jaw lathe chuck Ø 200 mm no. 5 cast Centrally clamping (chuck flange 3450212 required)	3450210
Chuck flange lathe chuck Ø 200 mm no. 5 (lathe chuck 3450210)	3450212
Clamping disc Ø 320 mm no. 5	3442979
BISON chuck flange for lathe chuck Ø 160 mm (Szf 3450245)	3450246
BISON collet chuck 16C - Ø 160 mm (requires chuck flange 3450246)	3450245
Lathe tool set HM 25 mm, 5-part (see page 188)	3441623
Interchangeable gear set for imperial and modular thread	3444160
Levelling platen SE 55 (8 pcs. required)	3352981

*Important information on transport surcharges and „General notes on operating our machines“ on page 249

**The lathe (frequency converter) complies with the DIN EN 55011 standard: class C3 - Note for operation with frequency converter on page 249

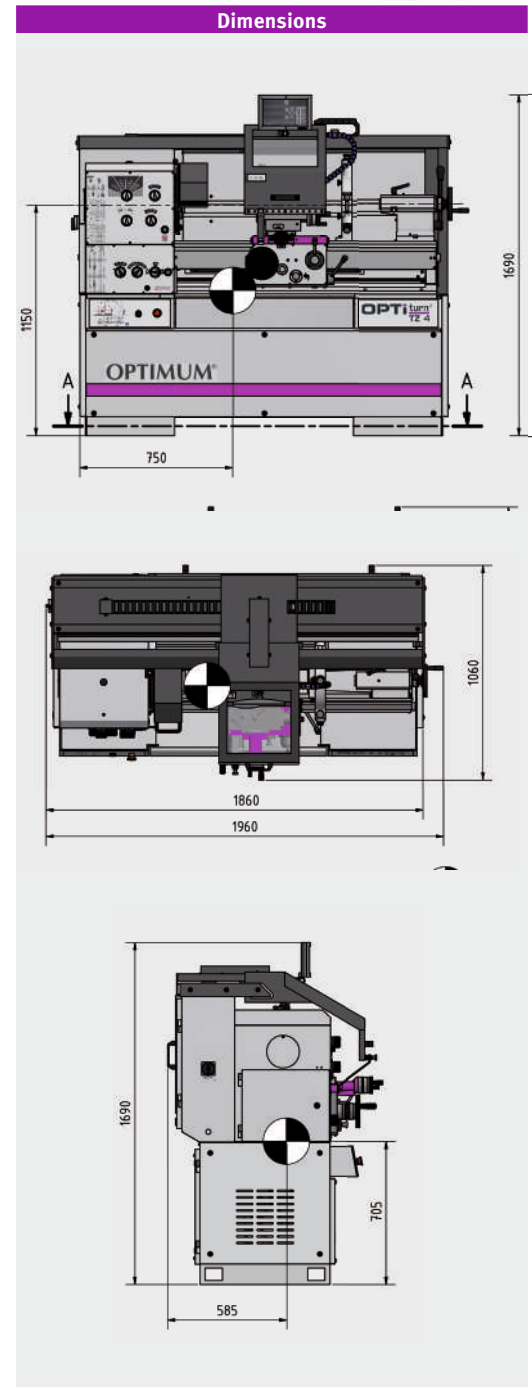

**Remember to order
a lathe chuck**

Scope of supply

- › Steady rest passageway Ø 10 - 130 mm
- › Follow rest passageway Ø 10 - 100 mm
- › Reduction sleeve MT 3 and MT 6
- › Fixed centre MT 3
- › Quick change tool holder 5-B
- › Tool holder 25 x 120 type D for square chisels 20mm
- › Replaceable gear set for metric thread
- › Machine initially filled with premium grade oil
- › Operating tool
- › More accessories for lathes from page 180

Preface

Drilling

Milling

Turning

Saws

Grinding

Polishing

Lamps

Measuring

Heavy leading and feed spindle lathes, characterised by excellent flexibility, precision and economy. Featuring Siemens inverter Vario drive

Facts that impress in terms of quality, performance and price

- ▶ Tempered and polished z-axis guideway
- ▶ Spindle collet Camlock DIN ISO 702-2 no. 8
- ▶ Precision slide
- ▶ Hand wheels with adjustable fine scaling 0.04 / 0.02 mm
- ▶ All guides adjustable using cleats
- ▶ Shafts, gears and main spindle run in oil bath
- ▶ Adjustment range top slide $\pm 90^\circ$
- ▶ Guaranteed concentricity of spindle nose better than 0.015 mm
- ▶ Gearwheels smooth running, tempered and ground borne on 2-readjustable precision taper rollers
- ▶ Clear-cut selector lever for switching the feed speeds
- ▶ Closed design of the quick shift feed gear
- ▶ Gears and shafts tempered and ground, running in oil bath on precision bearings
- ▶ Hand wheels decoupled and approved in line with EN 23125
- ▶ Two-channel CW/CCW switch approved in line with EN 23125
- ▶ Switch with lifecycle calculation, approved in line with EN ISO 13849
- ▶ Right-handed/left-handed rotation switchable on bed slide, switchable via switching spindle
- ▶ Central lubrication in bed slide
- ▶ Leading spindle cover
- ▶ Emergency stop button, motor circuit breaker, lockable main switch
- ▶ Emergency stop device with foot pedal
- ▶ Safety hand wheels with release function in the X and Z axis
- ▶ Tailstock adjustable ± 10 mm for turning spheres
- ▶ Tailstock spindle sleeve and handwheel with adjustable fine scaling 0.025 mm
- ▶ Fast, easy adjustment without tools thanks to clamping lever
- ▶ Grey cast iron prism bed with strong ribbing, induction tempered and precision ground
- ▶ Coolant system featuring separate coolant tank, fill level display and oil trap; easy and complete draining and cleaning as per DIN
- ▶ LED machine lamp in chip guard
- ▶ Two speeds
- ▶ Spindle bore/bar passage $\varnothing 105$ mm
- ▶ Siemens Sinamics frequency inverter / Safety Integrated
- ▶ Electrical system with Siemens components
- ▶ Energy chain for material-friendly cable and hose guiding
- ▶ Scale on thread gauge adjustable
- ▶ Quick change tool holder SWH 7-C
- ▶ 1 tool holder 32 x 150 type D for square chisels 25 mm
- ▶ Digital position display DPA 21
- ▶ Glass scales

Control Cabinet

- > 24 Volt DC Power Supply
- > All contactors und relays by Siemens or Schneider



Inverter SINAMICS G120D



More information: „SIEMENS SINAMICS G 120D Frequency inverters“ on page 136

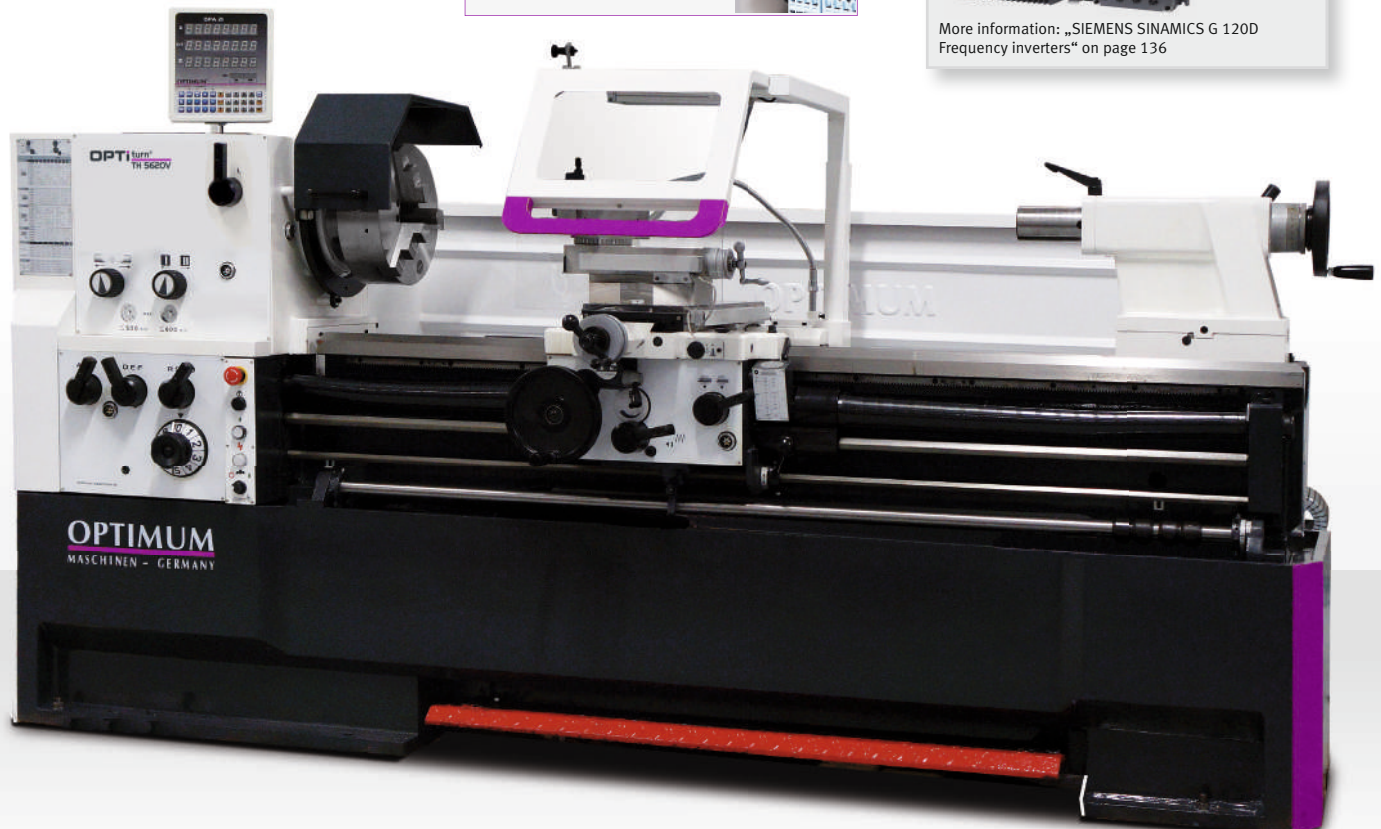

Fig.: TH 5615V - Shown with optional lathe chuck

Technical specifications, accessories and dimensions

Model	TH 5620V
Article no.	3462175
Technical specifications	
Electrical connection	400 V / 3 Ph ~50 Hz
Total rated value	8.5 kW
Coolant pump motor	125 Watts
Spindle	
Drive motor	7.5 kW
Spindle taper	Ø 113 mm (taper 1:20)
Spindle seat	Camlock DIN ISO 702-2 No. 8
Spindle bore, bar passage diameter	Ø 105 mm
Quick change tool holder	SWH 7-C
Work area	
Centre height	280 mm
Centre width	1 910 mm
Swing Ø over machine bed	560 mm
Swing in the bed bridge	790 mm
Turning length in bed bridge	170 mm
Swing over cross slide	355 mm
Bed width	350 mm
Speed range	
Spindle speed	25 - 1 600 rpm
Number of speeds	2 speeds; electronically controlled
Travel	
Top slide travel	130 mm
Cross slide travel	316 mm
Feeds and pitches	
Longitudinal feed within the range	0.031 - 1.7 mm/U (42)
Cross feed within	0.014 - 0.784 mm/U (42)
Pitch - metric in range	0.1 - 14 mm/U (47)
Pitch - inch in range	112 - 2 turns/inch (60 pitches)
Diametral pitch in range	4 - 112 turns/π (50 pitch)
Modular thread in range	0.1 - 7 mm x π (34 thread)
Tailstock	
Tailstock seat	MT 5
Spindle sleeve diameter / stroke	Ø 75 mm / 180 mm
Dimensions	
Length x width x height	3 340 x 1 150 x 1 650 mm
Weight	2 720 kg

Lathe chuck	Article no.
OPTIMUM lathe chucks	
Three-jaw lathe chuck Ø 315 mm no. 8, centric	3442768
Four-jaw lathe chuck Ø 315 mm no. 8, centric	3442856
Four-jaw lathe chuck Ø 315 mm no. 8, individual	3442888
BISON lathe chucks	
Three-jaw lathe chuck Ø 315 mm no. 8, centric	3450335
Four-jaw lathe chuck Ø 315 mm no. 8, centric	3450385
› Information about lathe chucks from page 180	

Accessories	Article no.
Clamping disc Ø 450 mm no. 8	3442982
Travelling centre MT 5	3440705
BISON co-travelling centre MT 5	3451005
Spare tool holder 40 x 160 type H for round	3384326
Spare tool holder 32 x 150 Type D square	3384308
Lathe tool set HM 32 mm, 5-part (see page 189)	3441674
Position stop with granular adjustment	3444023

*Important information on transport surcharges and „General notes on operating our machines“ on page 249

**The lathe (frequency converter) complies with the DIN EN 55011 standard: class C3 - Note for operation with frequency converter on page 249

Dimensions

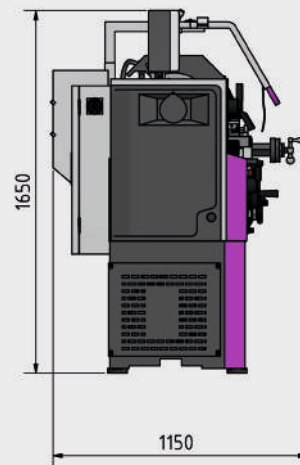
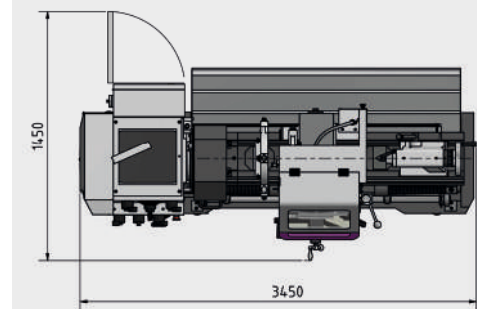
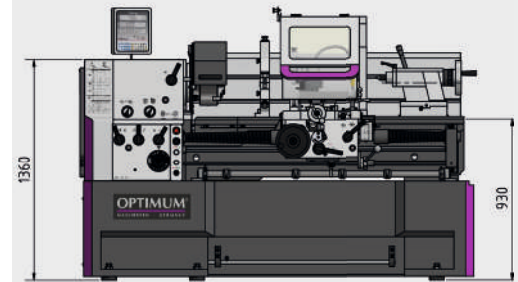

Scope of supply

- › Steady rest passageway max. Ø 165 mm
- › Follow rest passageway max. Ø 95 mm
- › LED machine lamp
- › Reduction sleeve Ø 113 mm / MT 5
- › One fixed and one alloyed centre MT 5
- › Quick change tool holder 7-C
- › Tool holder 32 x 150 type D for square chisels 25 mm
- › Thread gauge
- › Replaceable gear set
- › Gear wheels for threading gauge (metric)
- › Machine initially filled with premium grade oil
- › Operating tool

Remember to order a lathe chuck

Preface

Drilling

Milling

Turning

Saws

Grinding

Polishing

Lamps

Measuring

Heavy leading and feed spindle lathes, characterised by excellent flexibility, precision and economy.
With DPA 21 digital position display and quick change tool holder.

Facts that impress in terms of quality, performance and price

- ▶ Tempered and polished z-axis guideway
- ▶ Spindle collet Camlock DIN ISO 702-2 no. 8
- ▶ Precision slide
- ▶ Hand wheels with adjustable fine scaling 0.04 / 0.02 mm
- ▶ All guides adjustable using cleats
- ▶ Gears and shafts running in oil bath
- ▶ Adjustment range top slide $\pm 90^\circ$
- ▶ Guaranteed concentricity of spindle nose better than 0.015 mm
- ▶ Main spindle runs in oil bath
- ▶ Gearwheels smooth running, tempered and ground borne on 2 re-adjustable precision taper rollers
- ▶ Clear-cut selector lever for switching the feed speeds
- ▶ Closed design of the quick shift feed gear
- ▶ Gears and shafts tempered and ground, running in oil bath on precision bearings
- ▶ Hand wheels decoupled and approved in line with EN 23125
- ▶ Two-channel CW/CCW switch approved in line with EN 23125
- ▶ Switch with lifecycle calculation, approved in line with EN ISO 13849
- ▶ Right-handed/left-handed rotation switchable on bed slide, switchable via switching spindle
- ▶ Central lubrication in bed slide
- ▶ Leading spindle cover
- ▶ emergency stop button, motor circuit breaker, lockable main switch
- ▶ Emergency stop device with foot pedal
- ▶ Safety hand wheels with release function in the X and Z axis
- ▶ Tailstock adjustable ± 10 mm for turning spheres
- ▶ Tailstock spindle sleeve and handwheel with adjustable fine scaling 0.025 mm
- ▶ Fast, easy adjustment without tools thanks to clamping lever
- ▶ Grey cast iron prism bed with strong ribbing, induction tempered and precision ground
- ▶ Coolant system featuring separate coolant tank, fill level display and oil trap; easy and complete draining and cleaning as per DIN
- ▶ LED machine lamp in chip guard
- ▶ Electrical system with Siemens components
- ▶ Energy chain for material-friendly cable and hose guiding
- ▶ Scale on thread gauge adjustable
- ▶ Quick change tool holder SWH 7-C
- ▶ 1 tool holder 32 x 150 type D for square chisels 25 mm

Control Cabinet

- > 24 Volt DC Power Supply
- > All contactors und relays by Siemens or Schneider

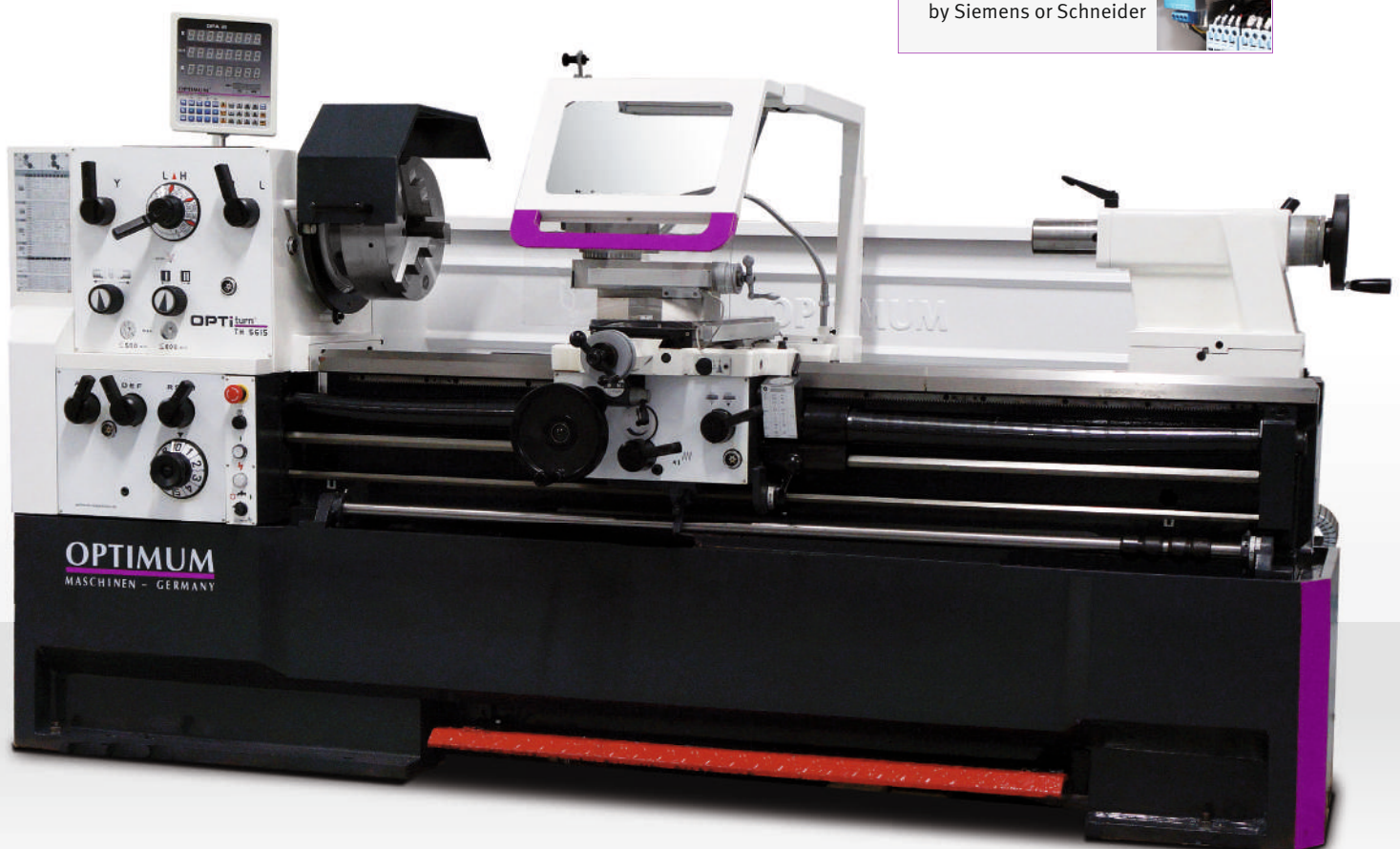

Fig.: TH 5615D - Shown with optional lathe chuck

Technical specifications, accessories and dimensions

Model	TH 5615D	TH 5620D	TH 5630D
Article no.	3462160	3462170	3462180
Technical specifications			
Electrical connection	400 V / 3 Ph ~50 Hz		
Total rated value	8.5 kW		
Coolant pump motor	125 Watts		
Spindle			
Drive motor	7.5 kW		
Spindle taper	MT 7		
Spindle seat	Camlock DIN ISO 702-2 No. 8		
Spindle bore, bar passage diameter	Ø 80 mm		
Quick change tool holder height	SWH 7-C		
Work area			
Centre height	280 mm		
Centre width	1 420 mm	1 910 mm	2 910 mm
Swing Ø over machine bed	560 mm		
Swing in the bed bridge	790 mm		
Turning length in bed bridge	170 mm		
Swing over cross slide	355 mm		
Bed width	350 mm		
Speed range			
Spindle speed	25 - 1 600 rpm		
Number of speeds	12 speeds		
Travel			
Top slide travel	130 mm		
Cross slide travel	316 mm		
Feeds and pitches			
Longitudinal feed within the range	0.059 - 1.646 mm/U (35)		
Cross feed within	0.020 - 0.573 mm/U (35)		
Pitch - metric in range	0.2 - 14 mm/U (47)		
Pitch - inch in range	112 - 2 turns/inch (60 pitches)		
Diametral pitch in range	4 - 112 turns/π (50 pitch)		
Modular thread in range	0.1 - 7 mm x π (34 thread)		
Tailstock			
Tailstock seat	MT 5		
Spindle sleeve diameter / stroke	Ø 75 mm / 180 mm		
Dimensions			
Length	2 950 mm	3 450 mm	4 450 mm
width x height	1 150 x 1 650 mm		
Weight	2 300 kg	2 720 kg	3 000 kg

Lathe chuck	Art no.
OPTIMUM lathe chucks	
Three-jaw lathe chuck Ø 315 mm no. 8, centric	3442768
Four-jaw lathe chuck Ø 315 mm no. 8, centric	3442856
Four-jaw lathe chuck Ø 315 mm no. 8, individual	3442888
BISON lathe chucks	
Three-jaw lathe chuck Ø 315 mm no. 8, centric	3450335
Four-jaw lathe chuck Ø 315 mm no. 8, centric	3450385
Accessories	
Clamping disc Ø 450 mm no. 8	3442982
Travelling centre MT 5	3440705
BISON co-travelling centre MT 5	3451005
Spare tool holder 40 x 160 type H for round	3384326
Spare tool holder 32 x 150 Type D square	3384308
Lathe tool set HM 32 mm, 5-part (see page 189)	3441674
Vibration damping machine base SE3 (6 pcs. required)	3381018
Position stop with granular adjustment	3444022

*Important information on transport surcharges and „General notes on operating our machines“ on page 249

Dimensions

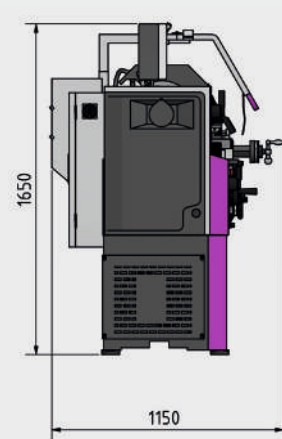
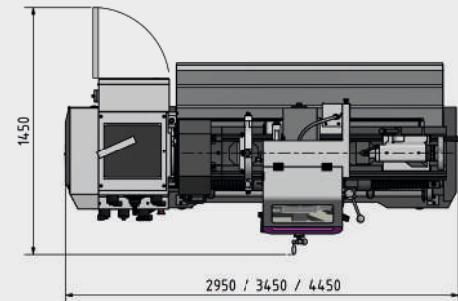
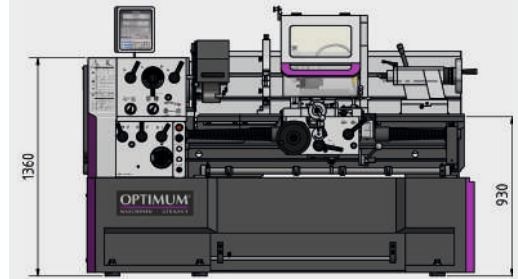

Scope of supply

- › Steady rest passageway max. Ø 165 mm
- › Follow rest passageway max. Ø 95 mm
- › LED machine lamp
- › Reduction sleeve MT 7 / MT 5
- › One fixed and one alloyed centre MT 5
- › Quick change tool holder 7-C
- › Tool holder 32 x 150 type D for square chisels 25 mm
- › Thread gauge
- › Replaceable gear set
- › Gear wheels for threading gauge (metric)
- › Machine initially filled with premium grade oil
- › Operating tool

**Remember to order
a lathe chuck**

Preface

Drilling

Milling

Turning

Saws

Grinding

Polishing

Lamps

Measuring

Precision feed and lead spindle lathe – unique in terms of precision and operation with Siemens inverter Vario drive

Facts that impress in terms of quality, performance and price

- ▶ Tempered and polished z-axis guideway
- ▶ Precision slide
- ▶ Hand wheels with adjustable fine scaling 0.04 / 0.02 mm
- ▶ Quadruple tool holder
- ▶ All guides adjustable using cleats
- ▶ Shafts, gears and main spindle run in oil bath
- ▶ Adjustment range top slide $\pm 90^\circ$
- ▶ Guaranteed concentricity of spindle nose better than 0.015 mm
- ▶ Gearwheels smooth running, tempered and ground borne on 2 re-adjustable precision taper rollers
- ▶ Quick-switching feed gear with closed design, gears and shafts tempered and ground, running in oil bath on precision bearings
- ▶ Hand wheels decoupled and approved in line with EN 23125
- ▶ Two-channel CW/CCW switch approved in line with EN 23125
- ▶ Switch with lifecycle calculation, approved in line with EN ISO 13849
- ▶ Right-handed/left-handed rotation switchable on bed slide, switchable via switching spindle
- ▶ Mechanical longitudinal feed switch-off of bed slide with four configurable eccentrics
- ▶ Leading spindle cover
- ▶ Emergency stop device with foot pedal
- ▶ Safety hand wheels with release function in the X and Z axis
- ▶ Scale on thread gauge adjustable
- ▶ Central lubrication in bed slide
- ▶ Tailstock adjustable ± 10 mm for turning spheres
- ▶ Tailstock spindle sleeve and handwheel with adjustable fine scaling 0.025 mm
- ▶ Fast, easy adjustment without tools thanks to clamping lever
- ▶ Grey cast iron prism bed with strong ribbing, induction tempered and precision ground
- ▶ Coolant system featuring separate coolant tank, fill level display and oil trap; easy and complete draining and cleaning as per DIN
- ▶ Generously dimensioned chip guard with integrated LED machine lamp
- ▶ Quick change tool holder SWH 5-B
- ▶ Tool holder 25 x 120 type D for square chisels 20 mm
- ▶ Digital position display DPA 21 with speed display
- ▶ Lines routed in energy chain

Control Cabinet

- > 24 Volt DC Power Supply
- > All contactors und relays by Siemens or Eaton



Inverter SINAMICS G120D



More information: „SIEMENS SINAMICS G 120D Frequency inverters“ on page 136



Fig.: TH 4615V - Shown with optional lathe chuck

Technical specifications, accessories and dimensions

Model	TH 4615V
Article no.	3462125
Technical specifications	
Electrical connection	400 V / 3 Ph ~50 Hz
Total rated value	8.5 kW
Coolant pump motor	125 Watts
Spindle	
Drive motor	7.5 kW
Spindle taper	MT 7
Spindle seat	Camlock DIN ISO 702-2 No. 8
Spindle bore, bar passage diameter	Ø 80 mm
Quick change tool holder	SWH 5-B
Work area	
Centre height	230 mm
Centre width	1 560 mm
Swing Ø over machine bed	460 mm
Swing in the bed bridge	690 mm
Turning length in bed bridge	240 mm
Swing over cross slide	270 mm
Bed width	300 mm
Speed range	
Spindle speed	30 - 2 000 rpm
Number of speeds	Electronically controlled
Travel	
Top slide travel	125 mm
Cross slide travel	285 mm
Feeds and pitches	
Longitudinal feed within the range	0.031 - 1.7 mm/rev (42 feeds)
Cross feed within	0.014 - 0.784 mm/rev (42 feeds)
Pitch - metric in range	0.1 - 14 mm/rev (41 pitches)
Pitch - inch in range	112 - 2 turns/inch (41 pitches)
Diametral pitch in range	4 - 112 turns/π (50 thread)
Modular thread in range	0.1 - 7 mm x π (34 thread)
Tailstock	
Tailstock seat	MT 4
Spindle sleeve diameter / stroke	Ø 60 mm / 130 mm
Dimensions	
Length x width x height	2 765 x 1 065 x 1 550 mm
Weight	2 020 kg

Lathe chuck	Art no.
OPTIMUM lathe chucks	
Three-jaw lathe chuck Ø 315 mm no. 8, centric	3442768
Four-jaw lathe chuck Ø 315 mm no. 8, centric	3442856
Four-jaw lathe chuck Ø 315 mm no. 8, individual	3442888
BISON lathe chucks	
Three-jaw lathe chuck Ø 315 mm no. 8, centric	3450335
Four-jaw lathe chuck Ø 315 mm no. 8, centric	3450385
› Information about lathe chucks from page 180	

Accessories	Art no.
Clamping disc Ø 450 mm no. 8	3442982
Travelling centre MT 5	3440705
BISON co-travelling centre MT 5	3451005
Spare tool holder 40 x 160 type H for round	3384326
Spare tool holder 32 x 150 Type D square	3384308
Lathe tool set HM 32 mm, 5-part (see page 189)	3441674
Position stop with granular adjustment	3444022
› More accessories for lathes from page 184	

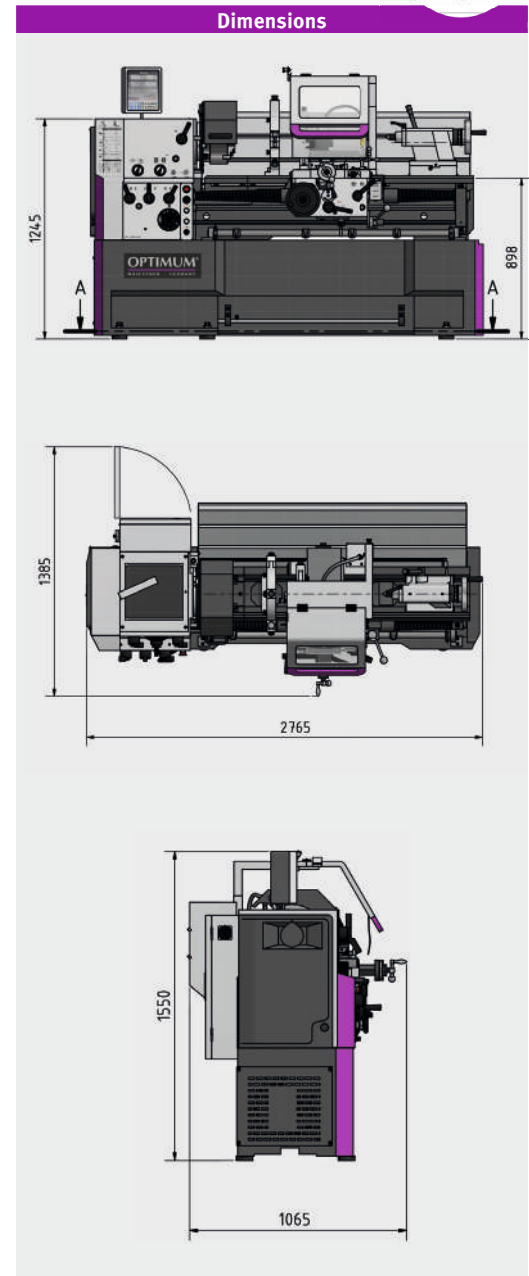

Remember to order a lathe chuck

Scope of supply
› Steady rest passageway max. Ø 160 mm
› Follow rest passageway max. Ø 100 mm
› LED machine lamp
› Reduction sleeve MT 7 / MT 4
› Fixed centre MT 4
› Quick change tool holder 5-B
› Tool holder 25 x 120 type D for square chisels 20 mm
› Thread gauge
› Replaceable gear set
› Machine initially filled with premium grade oil
› Operating tool

*Important information on transport surcharges and „General notes on operating our machines“ on page 249

**The lathe (frequency converter) complies with the DIN EN 55011 standard: class C3 - Note for operation with frequency converter on page 249

Precision leading and feed spindle lathes – unique in terms of precision and control.

With DPA 21 digital position display and quick change tool holder.

Facts that impress in terms of quality, performance and price

- ▶ Tempered and polished z-axis guideway
- ▶ Precision slide
- ▶ Hand wheels with adjustable fine scaling 0.04 / 0.02 mm
- ▶ Quadruple tool holder
- ▶ All guides adjustable using cleats
- ▶ Shafts, gears and main spindle run in oil bath
- ▶ Adjustment range top slide $\pm 90^\circ$
- ▶ Guaranteed concentricity of spindle nose better than 0.015 mm
- ▶ Gearwheels smooth running, tempered and ground borne on 2 re-adjustable precision taper rollers
- ▶ Quick-switching feed gear with closed design, gears and shafts tempered and ground, running in oil bath on precision bearings
- ▶ Hand wheels decoupled and approved in line with EN 23125
- ▶ Two-channel CW/CCW switch approved in line with EN 23125
- ▶ Switch with lifecycle calculation, approved in line with EN ISO 13849
- ▶ Right-handed/left-handed rotation switchable on bed slide, switchable via switching spindle
- ▶ Mechanical longitudinal feed switch-off of bed slide with four configurable eccentrics
- ▶ Leading spindle cover

- ▶ Emergency stop device with foot pedal
- ▶ Safety hand wheels with release function in the X and Z axis
- ▶ Scale on thread gauge adjustable
- ▶ Central lubrication in bed slide
- ▶ Tailstock adjustable ± 10 mm for turning spheres
- ▶ Tailstock spindle sleeve and handwheel with adjustable fine scaling 0.025 mm
- ▶ Fast, easy adjustment without tools thanks to clamping lever
- ▶ Grey cast iron prism bed with strong ribbing, induction tempered and precision ground
- ▶ Coolant system featuring separate coolant tank, fill level display and oil trap; easy and complete draining and cleaning as per DIN
- ▶ Generously dimensioned chip guard with integrated LED machine lamp
- ▶ Quick change tool holder SWH 5-B
- ▶ Tool holder 25 x 120 type D for square chisels 250 mm
- ▶ Digital position display DPA 21 with speed display

As of TH 4615:

- ▶ Lines routed in energy chain

Control Cabinet

- > 24 Volt DC Power Supply
- > All contactors und relays by Siemens or Schneider

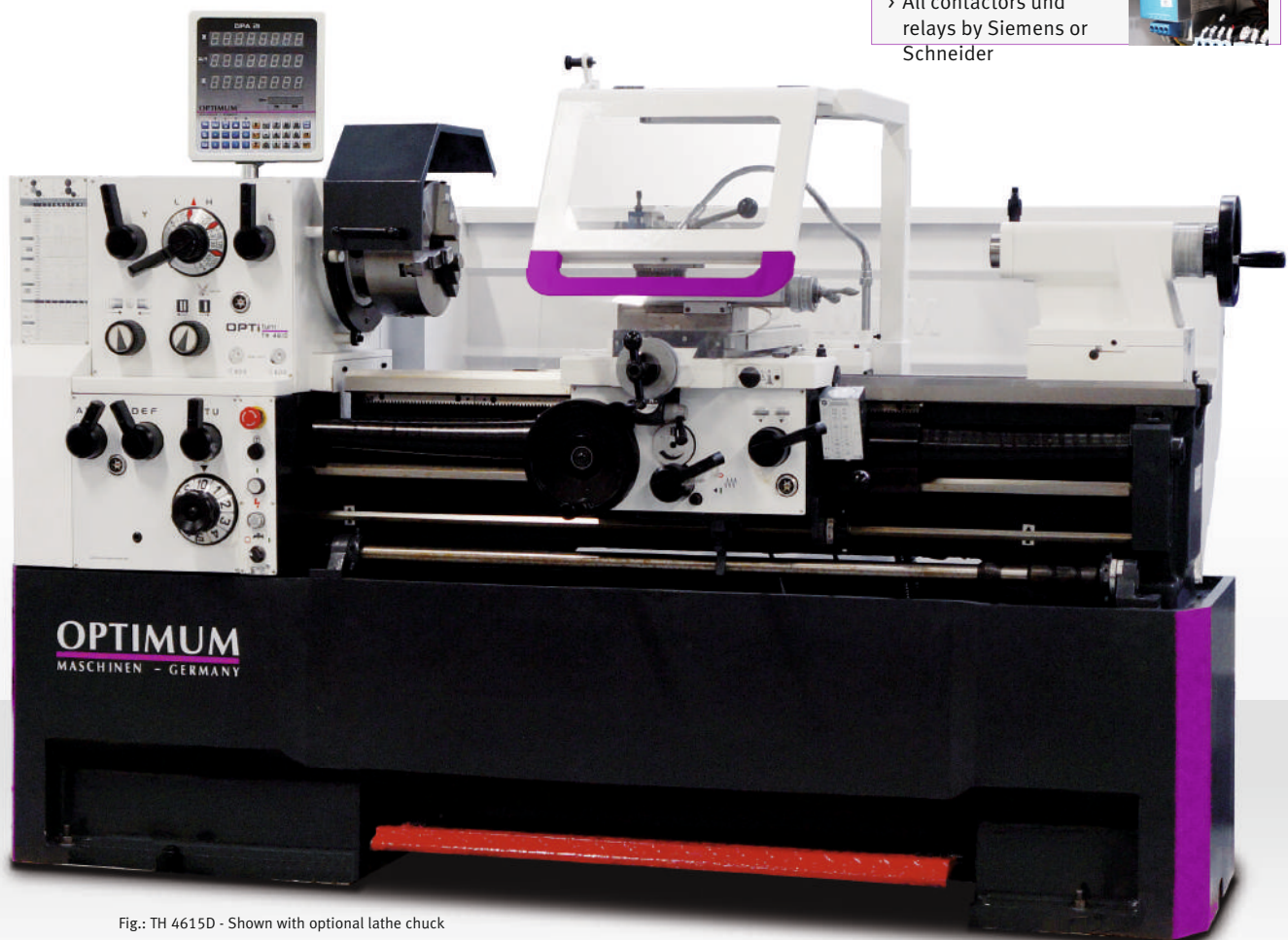

Fig.: TH 4615D - Shown with optional lathe chuck

Technical specifications, accessories and dimensions

Model	TH 4610D	TH 4615D	TH 4620D
Article no.	3462110	3462120	3462130
Technical specifications			
Electrical connection	400 V / 3 Ph ~50 Hz		
Total rated value	5.8 kW		
Coolant pump motor	125 Watts		
Spindle			
Drive motor	5.5 kW		
Spindle taper	MT 6		
Spindle seat	Camlock DIN ISO 702-2 No. 6		
Spindle bore, bar passage diameter	Ø 58 mm		
Quick change tool holder	SWH 5-B		
Work area			
Centre height	230 mm		
Centre width	1 060 mm	1 560 mm	2 060 mm
Swing Ø over machine bed	460 mm		
Swing in the bed bridge	690 mm		
Turning length in bed bridge	240 mm		
Swing over cross slide	270 mm		
Bed width	300 mm		
Speed range			
Spindle speed	25 - 2 000 rpm		
Number of speeds	12 speeds		
Travel			
Top slide travel	125 mm		
Cross slide travel	285 mm		
Feeds and pitches			
Longitudinal feed within the range	0.031 - 1.7 mm/rev (42 feeds)		
Cross feed within	0.014 - 0.784 mm/rev (42 feeds)		
Pitch - metric in range	0.1 - 14 mm/rev (41 pitches)		
Pitch - inch in range	112 - 2 turns/inch (41 pitches)		
Diametral pitch in range	4 - 112 turns/π (50 thread)		
Modular thread in range	0.1 - 7 mm x π (34 thread)		
Tailstock			
Tailstock seat	MT 4		
Spindle sleeve diameter / stroke	Ø 60 mm / 130 mm		
Dimensions			
Length	2 215 mm	2 765 mm	3 265 mm
width x height	1 065 x 1 550 mm		
Weight	1 720 kg	1 977 kg	2 400 kg

Accessories	Art no.
Spare tool holder 25 x 120 Type D for square	3384306
Spare tool holder 32 x 130 type H for round chisels	3384324
Lathe tool set HM 20 mm, 5-part (see page 188)	3441670
Lathe tool set HM 20 mm, 5-part Extension kit (see page 188)	3441617
Clamping disc Ø 350 mm no. 6	3442980
Universal collet chuck device 5C	3441507
Collet kit 3 - 25 mm, 5C, 17-part	3441509
Vibration damping base SE 3 (6 pcs. needed)	3381018
Collet chuck 5C - Camlock no. 6	3441556
Position stop with granular adjustment	3444022
› More accessories for lathes from page 184	

Lathe chuck	Art no.
OPTIMUM lathe chucks	
Three-jaw lathe chuck Ø 250, no. 6, centre clamping	3442765
Four-jaw lathe chuck Ø 250 mm no. 6, centre clamping	3442852
Four-jaw lathe chuck Ø 250 mm no. 6, individual clamping	3442884
BISON lathe chucks	
Three-jaw lathe chuck Ø 250, no. 6, centre clamping	3450330
Four-jaw lathe chuck Ø 250 mm no. 6, centre clamping	3450380
› Information about lathe chucks from page 180	

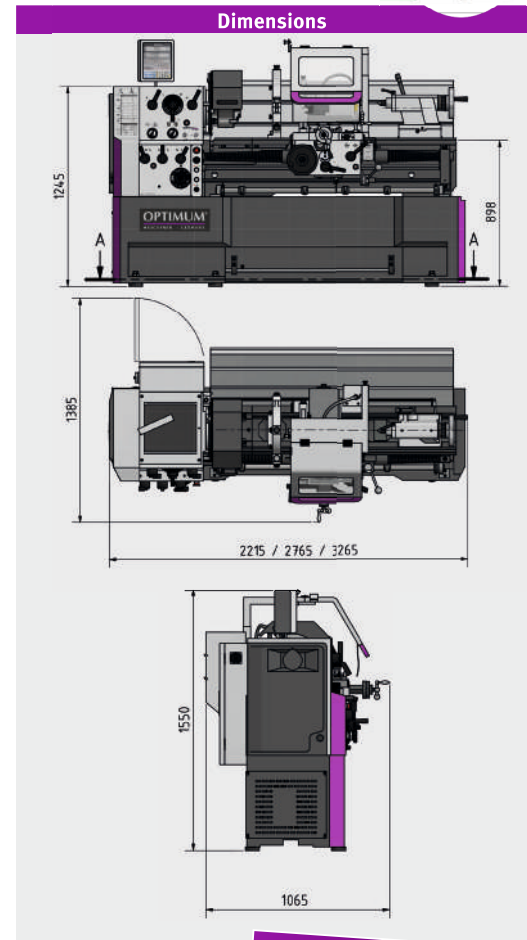

**Remember to order
a lathe chuck**

Scope of supply

- › Steady rest passageway max. Ø 160 mm
- › Follow rest passageway max. Ø 100 mm
- › LED machine lamp
- › Reduction sleeve MT 6 / MT 4
- › One fixed and one alloyed centre MT 4
- › Quick change tool holder 5-B
- › Tool holder 25 x 120 type D for square chisels 20 mm
- › Thread gauge
- › Replaceable gear set
- › Gear wheels for threading gauge (metric)
- › Machine initially filled with premium grade oil
- › Operating tool

Precision leading and feed spindle machines, mature technology, fully equipped, easy to operate. TH 5620V featuring Siemens inverter Vario drive

Facts that impress in terms of quality, performance and price

- ▶ Tempered and polished z-axis guideway
- ▶ Spindle collet Camlock DIN ISO 702-2 no. 6
- ▶ Precision slide
- ▶ Hand wheels with adjustable fine scaling 0.04 / 0.02 mm
- ▶ Quadruple tool holder
- ▶ All guides adjustable using cleats
- ▶ Adjustment range top slide $\pm 90^\circ$
- ▶ Guaranteed concentricity of spindle nose better than 0.015 mm
- ▶ Main spindle runs in oil bath
- ▶ Gearwheels smooth running, tempered and ground borne on 2 re-adjustable precision taper rollers
- ▶ Hand wheels decoupled and approved in line with EN 23125
- ▶ Two-channel CW/CCW switch approved in line with EN 23125
- ▶ Switch with lifecycle calculation, approved in line with EN ISO 13849
- ▶ All metric pitches in range from 0.2 to 14 mm/rev and all inch pitches in range of 72 - 2 turns per inch configurable on control panel without replacing the interchangeable gear wheels thanks to gear shift
- ▶ Right-handed/left-handed rotation switchable on bed slide, switchable via switching spindle
- ▶ Central lubrication in bed slide
- ▶ Chassis and machine bed single-piece cast meehanite
- ▶ Leading spindle cover
- ▶ Emergency stop device with foot pedal
- ▶ Safety hand wheels with release function in the X and Z axis
- ▶ Tailstock adjustable ± 10 mm for turning spheres
- ▶ Tailstock spindle sleeve and handwheel with adjustable fine scaling 0.025 mm
- ▶ Fast, easy adjustment without tools thanks to clamping lever
- ▶ Grey cast iron prism bed with strong ribbing, induction tempered and precision ground
- ▶ Coolant system featuring separate coolant tank, fill level display and oil trap; easy and complete draining and cleaning as per DIN
- ▶ LED machine lamp in chip guard
- ▶ Siemens Sinamics frequency inverter / Safety Integrated
- ▶ Quick change tool holder 5-B
- ▶ Tool holder 20 x 100 type D for square chisels 18 mm

Control Cabinet

- > 24 Volt DC Power Supply
- > All contactors and relays by Siemens or Schneider



Inverter SINAMICS G120D



More information: „SIEMENS SINAMICS G 120D Frequency inverters“ on page 136

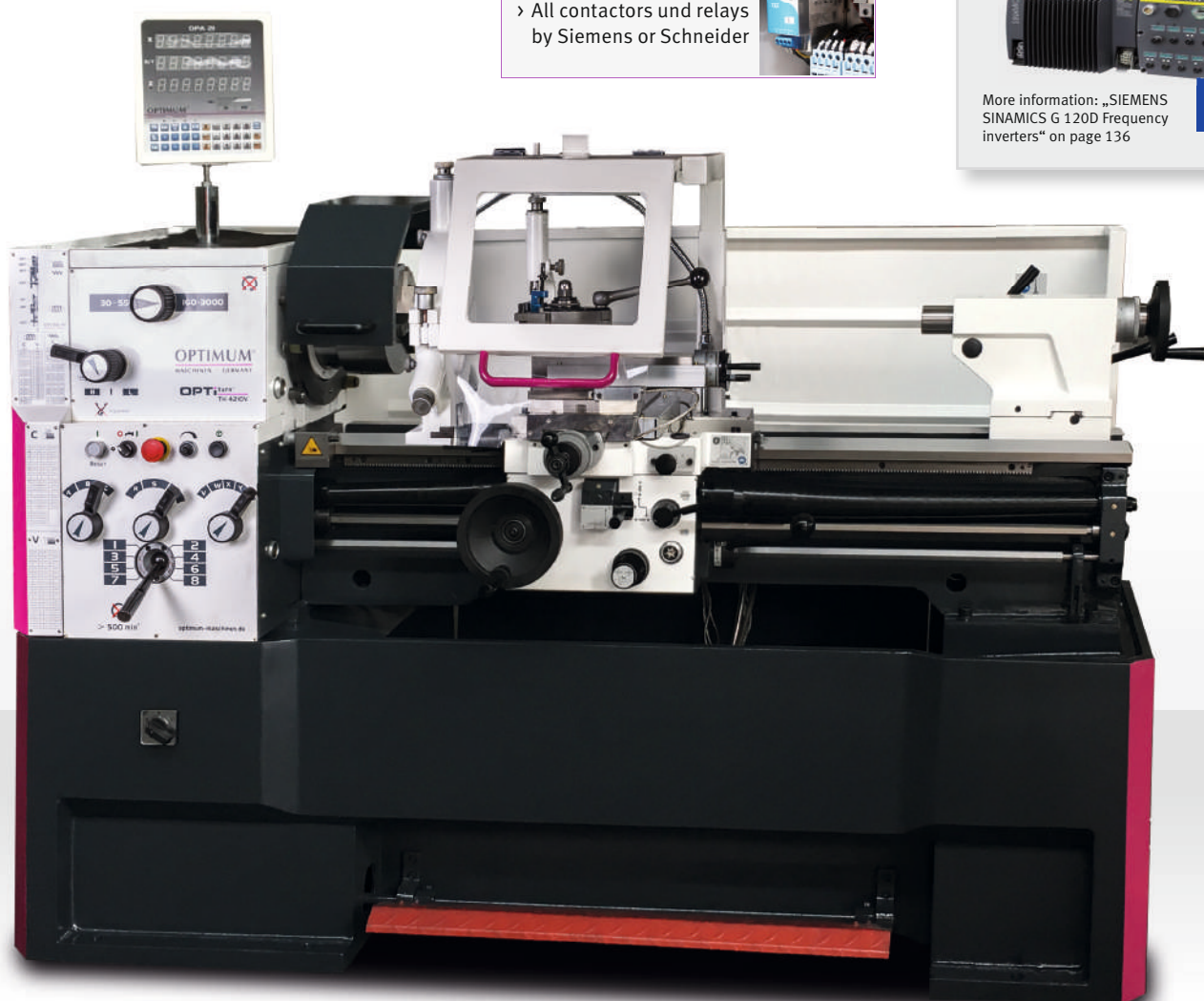
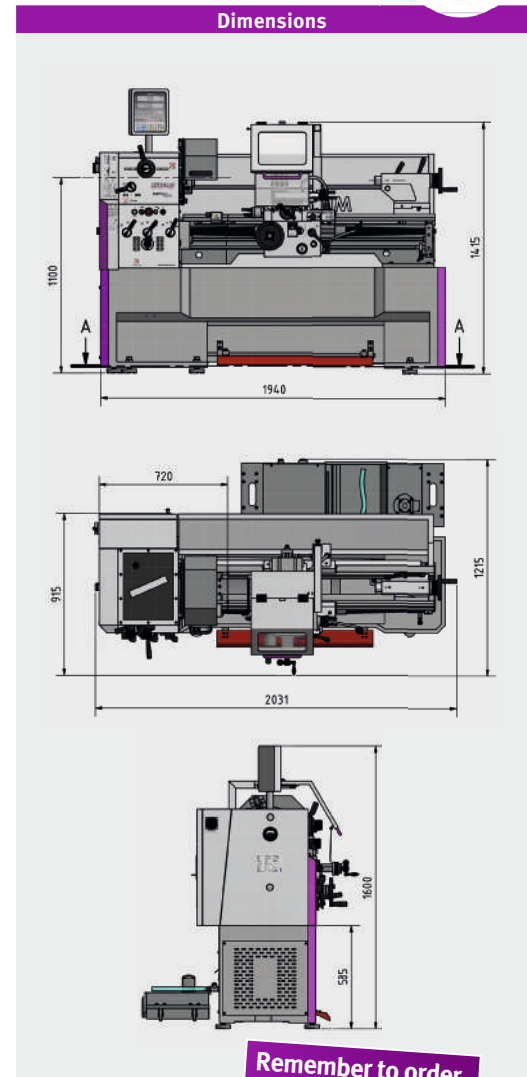

Fig.: TH 4210V - Shown with optional lathe chuck

Technical specifications, accessories and dimensions

Model	TH 4210V
Article no.	3462060
Technical specifications	
Electrical connection	400 V / 3 Ph ~ 50 Hz
Total rated value	5.6 kW
Coolant pump motor	100 W
Spindle	
Drive motor	5.5 kW
Spindle taper	MT 6
Spindle seat	Camlock DIN ISO 702-2 No. 6
Spindle bore, bar passage diameter	Ø 52 mm
Quick change tool holder height	25 mm
Work area	
Centre height	210 mm
Centre width	1 000 mm
Swing Ø over machine bed	420 mm
Swing in the bed bridge	590 mm
Turning length in bed bridge	260 mm
Swing over cross slide	250 mm
Bed width	250 mm
Speed range	
Spindle speed	30 - 3 000 rpm
Number of speeds	2 speeds. Electronically controlled
Travel	
Top slide travel	140 mm
Cross slide travel	230 mm
Feeds and pitches	
Longitudinal feed within the range	0.05 - 1.7 mm/rev (17 feeds)
Cross feed within	0.025 - 0.85 mm/rev (17 feeds)
Pitch - metric in range	0.2 - 14 mm/rev (39 pitches)
Pitch - inch in range	72 - 2 turns/inch (45 pitches)
Diametral pitch in range	8 - 44 turns/π (21 pitch)
Modular thread in range	0.3 - 3.5 mm x π (18 thread)
Tailstock	
Tailstock seat	MT 4
Tailstock spindle sleeve diameter / stroke	Ø 50 mm / 120 mm
Dimensions	
Length x width x height	2 031 x 915 (coolant tank 1 215) x 1 415 (DPA 1 600) mm
Weight	1 160 kg

Accessories	Art no.
Quick change tool holder SWH 5-B	3384305
Factory assembly SWH 5-B	9000400
Spare tool holder 25 x 120 Type D for square chisels	3384306
Spare tool holder 32 x 130 type H for round chisels	3384324
Lathe tool set HM 25 mm, 5-part (see page 188)	3441672
Lathe tool set HM 25 mm, 5-part Extension kit (see page 188)	3441623
Lathe tool set HM 20 mm, 5-part (see page 188)	3441670
Lathe tool set HM 20 mm, 5-part, Extension kit (see page 188)	3441617
Vibration damper SE 2 (6 pcs. needed)	3381016
Vibration damper SE 85 (6 pcs. needed)	3352982
Clamping block set 20-05	3440654
› More accessories for lathes from page 184	



Scope of supply

- › Steady rest passageway Ø 15 - 145 mm
- › Follow rest passageway Ø 10 - 75 mm
- › LED machine lamp
- › Reduction sleeve MT 6 - MT 4
- › Fixed centre MT 4
- › Replaceable gear set
- › Position stop with granular adjustment
- › Machine initially filled with premium grade oil
- › Operating tool
- › Quick change tool holder 5-B
- › Tool holder 25 x 120 type D for square chisels 20 mm

Lathe chuck	Art no.
OPTIMUM lathe chucks	
Three-jaw lathe chuck Ø 250 mm no. 6, centric	3442765
Four-jaw lathe chuck Ø 250 mm no. 6, centric	3442852
Four-jaw lathe chuck Ø 250 mm no. 6, individual	3442884
BISON lathe chucks	
Three-jaw lathe chuck Ø 250 mm no. 6, centric	3450330
Four-jaw lathe chuck Ø 250 mm no. 6, centric	3450380
Three-jaw lathe check Ø 250 mm no. 6, steel	3450530
Four-jaw lathe chuck Ø 250 mm no. 6, steel	3450580
› Information about lathe chucks from page 180	

*Important information on transport surcharges and „General notes on operating our machines“ on page 249

**The lathe (frequency converter) complies with the DIN EN 55011 standard: class C3 - Note for operation with frequency converter on page 249

Precision leading and feed spindle machines, mature technology, fully equipped, easy to operate

Facts that impress in terms of quality, performance and price

- ▶ Tempered and polished z-axis guideway
- ▶ Spindle collet Camlock DIN ISO 702-2 no. 6
- ▶ Precision slide
- ▶ Hand wheels with adjustable fine scaling 0.04 / 0.02 mm
- ▶ Quadruple tool holder
- ▶ All guides adjustable using cleats
- ▶ Adjustment range top slide $\pm 90^\circ$
- ▶ Guaranteed concentricity of spindle nose better than 0.015 mm
- ▶ Main spindle runs in oil bath
- ▶ Gearwheels smooth running, tempered and ground borne on 2 re-adjustable precision taper rollers
- ▶ Hand wheels decoupled and approved in line with EN 23125
- ▶ Two-channel CW/CCW switch approved in line with EN 23125
- ▶ Switch with lifecycle calculation, approved in line with EN ISO 13849
- ▶ All metric pitches in range from 0.2 to 14 mm/rev and all inch pitches in range of 72 - 2 turns per inch configurable on control panel without replacing the interchangeable gear wheels thanks to gear shift
- ▶ Right-handed/left-handed rotation switchable on bed slide, switchable via switching spindle
- ▶ Central lubrication in bed slide
- ▶ Chassis and machine bed single-piece cast meehanite
- ▶ Leading spindle cover
- ▶ Emergency stop device with foot pedal
- ▶ Safety hand wheels with release function in the X and Z axis
- ▶ Tailstock adjustable ± 10 mm for turning spheres
- ▶ Tailstock spindle sleeve and handwheel with adjustable fine scaling 0.025 mm
- ▶ Fast, easy adjustment without tools thanks to clamping lever
- ▶ Grey cast iron prism bed with strong ribbing, induction tempered and precision ground
- ▶ Coolant system featuring separate coolant tank, fill level display and oil trap; easy and complete draining and cleaning as per DIN
- ▶ LED machine lamp in chip guard:
- ▶ **Digital position display DPA21**
 - › User-friendly membrane keyboard, splash water protected, sealed and dazzle free
 - › Sensor supplied for acquiring spindle speeds
 - › Glass scales

Control Cabinet

- › 24 Volt DC Power Supply
- › All contactors und relays by Siemens or Schneider



Fig.: TH 4210D - Shown with optional lathe chuck

Technical specifications, accessories and dimensions

Model	TH 4210	
Article no.	3462050	
	9,990.00	
Model	TH 4210D	TH 4215D
Article no.	3462055	3462070

Technical specifications		
Electrical connection	400 V / 3 Ph ~ 50 Hz	
Total rated value	4.6 kW	
Coolant pump motor	100 W	
Spindle		
Drive motor	4.5 kW	
Spindle taper	MT 6	
Spindle seat	Camlock DIN ISO 702-2 No. 6	
Spindle bore, bar passage diameter	Ø 52 mm	
Quick change tool holder height	20 mm	
Work area		
Centre height	210 mm	
Centre width	1 000 mm	1 500 mm
Swing Ø over machine bed	420 mm	
Swing in the bed bridge	590 mm	
Turning length in bed bridge	260 mm	
Swing over cross slide	250 mm	
Bed width	250 mm	
Speed range		
Spindle speed	45 - 1 800 rpm	
Number of speeds	16 speeds	
Travel		
Top slide travel	140 mm	
Cross slide travel	230 mm	
Feeds and pitches		
Longitudinal feed within the range	0.05 - 1.7 mm/rev (17 feeds)	
Cross feed within	0.025 - 0.85 mm/rev (17 feeds)	
Pitch - metric in range	0.2 - 14 mm/rev (39 pitches)	
Pitch - inch in range	72 - 2 turns/inch (45 pitches)	
Diametral pitch in range	8 - 44 turns/π (21 pitch)	
Modular thread in range	0.3 - 3.5 mm x π (18 thread)	
Tailstock		
Tailstock seat	MT 4	
Tailstock spindle sleeve diameter / stroke	Ø 50 mm / 120 mm	
Dimensions		
Length	1 940 mm	2,440 mm
Width x height	915 x 1 375 (DPA 1 600) mm	
Weight	1 160 kg	1 340 kg

Lathe chuck	Art no.
OPTIMUM cast lathe chucks	
Three-jaw lathe chuck Ø 250 mm no. 6, centric	3442765
Four-jaw lathe chuck Ø 250 mm no. 6, centric	3442852
Four-jaw lathe chuck Ø 250 mm no. 6, individual	3442884
BISON lathe chucks	
Three-jaw lathe chuck Ø 250 mm no. 6, cast Centre clamping	3450330
Four-jaw lathe chuck Ø 250 mm no. 6, cast Centre clamping	3450380
Three-jaw lathe check Ø 250 mm no. 6, steel Centre clamping	3450530
Four-jaw lathe chuck Ø 250 mm no. 6, steel Centre clamping	3450580
› Information about lathe chucks from page 184	

Accessories	Art no.
Quick change tool holder SWH 5-B	3384305
Factory assembly SWH 5-B	9000400
Spare tool holder 25 x 120 Type D for square chisels	3384306
Spare tool holder 32 x 130 type H for round chisels	3384324
Lathe tool set HM 20 mm, 5-part (see page 188)	3441670
Lathe tool set HM 20 mm, 5-part (see page 188)	3441617
Vibration damper SE 2 (6 pcs. needed)	3381016
Vibration damper SE 85 (6 pcs. needed)	3352982
Clamping block set 20-05	3440654
Universal collet chuck device 5C	3441507
› More accessories for lathes from page 180	

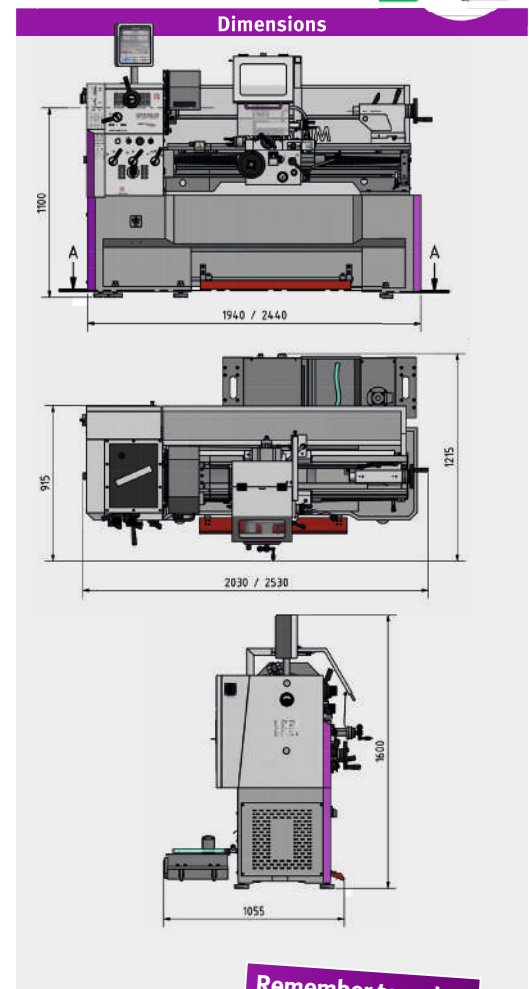

Remember to order a lathe chuck

Scope of supply

- › Steady rest passageway Ø 15 - 145 mm
- › Follow rest passageway Ø 10 - 75 mm
- › LED machine lamp
- › Reduction sleeve MT 6 - MT 4
- › One fixed and one alloyed centre MT 4
- › Replaceable gear set
- › Gear wheels for threading gauge (metric)
- › Position stop with granular adjustment
- › Machine initially filled with premium grade oil
- › Operating tool
- › Quad tool holder max. 20 mm

Fully equipped lathes for mechanics. Impressive precision and performance. TH 4010D with digital position display DPA 21. TH 4010V additionally with Siemens inverter Vario drive

Facts that impress in terms of quality, performance and price

- ▶ Tempered and polished z-axis guideway
- ▶ Spindle collet Camlock DIN ISO 702-2 no. 5
- ▶ Precision slide
- ▶ Hand wheels with adjustable fine scaling 0.04 / 0.02 mm
- ▶ Quadruple tool holder
- ▶ All guides adjustable using cleats
- ▶ Adjustment range top slide $\pm 90^\circ$
- ▶ Guaranteed concentricity of spindle nose better than 0.015 mm
- ▶ Main spindle runs in oil bath
- ▶ Gearwheels smooth running, tempered and ground
- ▶ Gears and shafts tempered and ground, running in oil bath on precision bearings
- ▶ Hand wheels decoupled and approved in line with EN 23125
- ▶ Two-channel CW/CCW switch approved in line with EN 23125
- ▶ Switch with lifecycle calculation, approved in line with EN ISO 13849
- ▶ DC 24 Volt electrical system
- ▶ Lockable main switch
- ▶ Right-handed/left-handed rotation switchable on bed slide
- ▶ Safety hand wheels with release function in the X and Z axis
- ▶ Tailstock adjustable ± 10 mm for turning spheres
- ▶ Tailstock spindle sleeve and handwheel with adjustable fine scaling 0.025 mm

- ▶ Fast, easy adjustment without tools thanks to clamping lever
- ▶ Grey cast iron prism bed with strong ribbing, induction tempered and precision ground
- ▶ Pull-out chip drawer with guide rails
- ▶ Emergency stop device with foot pedal
- ▶ Machine base with 3 covers (no compartments)
- ▶ Coolant system
- ▶ LED machine lamp in chip guard

TH 4010 / TH 4010D:

- ▶ Motor circuit switch

TH 4010D / TH 4010V:

▶ Digital position display DPA21

- › User-friendly membrane keyboard, splash water protected, sealed and dazzle free
- › Glass scales

TH 4010V:

- ▶ Siemens Sinamics frequency inverter / Safety Integrated
- ▶ Quick change tool holder 3-E
- ▶ Tool holder 20 x 100 type D for square chisels

Control Cabinet

- › 24 Volt DC Power Supply
- › All contactors und relays by Siemens or Schneider
- TH 4010V by Eaton



TH 4010V: Inverter SINAMICS G120D



More information: „SIEMENS SINAMICS G 120D Frequency inverters“ on page 136



Fig.: TH 4010D - Shown with optional lathe chuck

Technical specifications, accessories and dimensions

Model	TH 4010	TH 4010D	TH 4010V**
Article no.	3402070	3402080	3402085
Technical specifications			
Electrical connection	400 V / 3 Ph ~50 Hz		
Spindle			
Drive motor	1.5/2.4 kW	4 kW	
Spindle taper	MT 6		
Spindle seat	Camlock DIN ISO 702-2 No. 5		
Spindle bore, bar passage diameter	Ø 52 mm		
Quadruple tool holder mounting height	max. 16 mm		
Technical specifications			
Centre height	205 mm		
Centre width	1 000 mm		
Swing Ø over machine bed	410 mm		
Swing in the bed bridge	540 mm		
Turning length in bed bridge	165 mm		
Bed width	206 mm		
Speed range			
Spindle speed	45 - 1 800 rpm	30 - 3 000 rpm	
speeds	16 speeds	2 speeds; elec. control	
Travel			
Top slide travel	100 mm		
Cross slide travel	195 mm		
Feeds and pitches			
Longitudinal feed within the range	0.043 - 0.653 mm/rev (48 feeds)		
Cross feed within	0.015 - 0.206 mm/rev (48 feeds)		
Pitch - metric in range	0.4 - 7 mm/rev (42 pitches)		
Pitch - inch in range	70 - 4 turns/inch (42 pitches)		
Tailstock			
Tailstock seat	MT 3		
Tailstock- sleeve diameter/ sleeve travel	Ø 45 mm / 130 mm		
Dimensions			
Length x width x height	1 920 x 740 x 1 222 / 1 555 mm		
Net weight	775 kg	780 kg	

Lathe chuck	Art no.
OPTIMUM Four-jaw lathe chuck Ø 200 mm no. 5, centric	3442845
OPTIMUM Four-jaw lathe chuck Ø 200 mm no. 5, individual	3442880
BISON three-jaw lathe chuck Ø 200 mm no. 5, centric	3450315
BISON Four-jaw lathe chuck Ø 200 mm no. 5, centric	3450365
› Information about lathe chucks from page 180	

Accessories	Art no.
Quick change tool holder SWH 3-E	3384303
Factory assembly SWH 3-E	9000400
Spare tool holder 20 x 100 type D for square chisels	3384304
Spare tool holder 30 x 100 type H for round chisels	3384322
Lathe tool set 16 mm, 11-part (see page 186)	3441604
Lathe tool set 16 mm, 5-part (see page 186)	3441668
Lathe tool set 16 mm, 5-part "Made in Germany" (see page 186)	3441216
Lathe tool set 16 mm, 5-part (see page 186)	3441610
Collet chuck 5C	3441555
Collet kit 3 - 25 mm, 5C, 17-part	3441509
Vibration-damping machine base SE 2 (6 pcs. required)	3381016
› More accessories for lathes from page 184	

*Important information on transport surcharges and „General notes on operating our machines“ on page 249

**The lathe (frequency converter) complies with the DIN EN 55011 standard: class C2 - Note for operation with frequency converter on page 249

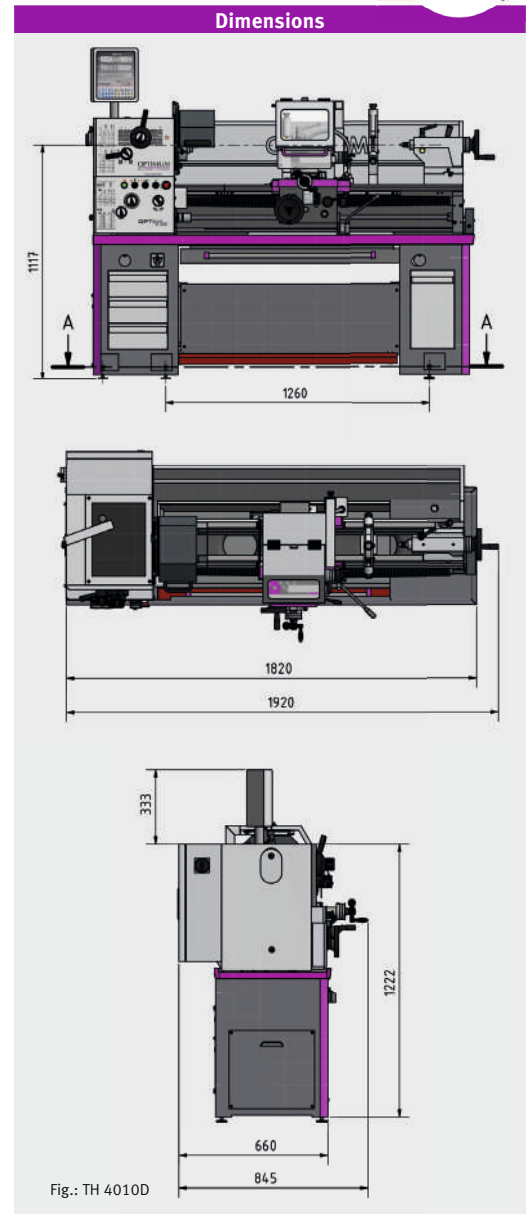

Remember to order a lathe chuck

Scope of supply

- › Steady rest passageway Ø 5 - 85 mm
- › Follow rest passageway Ø 5 - 65 mm
- › LED machine lamp
- › Reduction sleeve MT 6 - MT 3
- › Fixed centres MT 3
- › Fixed centre MT 3, alloyed
- › Travelling centre MT 3
- › Position stop with granular adjustment
- › Change gear kit
- › Machine initially filled with premium grade oil
- › Operating tool

TH 4010 / TH 4010D

- › Quadruplicate tool holder 16 mm

TH 4010V

- › Quick change tool holder 3-E
- › Tool holder 20 x 100 type D for square chisels

Preface

Drilling

Milling

Turning

Saws

Grinding

Polishing

Lamps

Measuring

Feed and lead spindle lathe impresses with rugged design and simple handling. TM 4010D with DPA 21 digital position display

Facts that impress in terms of quality, performance and price

- ▶ Tempered and polished z-axis guideways
- ▶ Spindle collet Camlock DIN ISO 702-2 no. 5
- ▶ Guaranteed concentricity of spindle nose better than 0.015 mm
- ▶ Gears and shafts tempered and ground, running in oil bath on precision bearings
- ▶ Tailstock with tempered and ground spindle sleeve
- ▶ DC 24 Volt electrical system
- ▶ All pitch gears made of steel, hardened and polished, shafts on needle bearings, all components lubricated in an oil bath
- ▶ Right-handed/left-handed rotation switchable on bed slide
- ▶ Safety hand wheels with release function in the X and Z axis
- ▶ Emergency stop device
- ▶ Perfectly concentric main spindle guarantees high load capacity thanks to use of precision taper roller bearings
- ▶ Chip compartment folds out for easy chip removal from front
- ▶ Machine chassis with rugged steel design
- ▶ Coolant pump with coolant tank and fill level display Tank removable for easy cleaning
- ▶ With safety device to prevent simultaneous operation of thread cutting and pitch mechanism
- ▶ Hand wheels decoupled and approved in line with EN 23125
- ▶ Switch with lifecycle calculation, approved in line with EN ISO 13849
- ▶ LED machine lamp in chip guard
- ▶ Motor electrically braked
- ▶ Three-jaw chuck Ø 200 mm, no. 5 included in standard scope of delivery
- ▶ User-friendly membrane keyboard
- ▶ Two-channel CW/CCW switch approved in line with EN 23125

TM 4010D
Digital position display DPA21

Control Cabinet

- > 24 Volt DC Power Supply
- > All contactors und relays by Siemens or Schneider



Fig.: TM 4010D

Technical specifications, accessories and dimensions

Model	TM 4010	TM 4010D
Article no.	3403040	3403045
Machine data		
Electrical connection	400 V / 3 Ph ~50 Hz	
Total rated value	2.3 kW	
Coolant pump motor	100 Watts	
Spindle		
Drive motor	2.2 kW	
Spindle taper	MT 6	
Spindle seat	Camlock DIN ISO 702-2 No. 5	
Spindle bore, bar passage diameter	Ø 53 mm	
Quick change tool holder	SWH 3-E	
Work areas		
Centre height	200 mm	
Centre width	1 000 mm	
Swing over cross slide	400 mm	
Swing in the bed bridge	250 mm	
Speed range		
Spindle speeds	70 - 2 000 rpm	
Number of speeds	8 speeds	
Travel		
Top slide travel	98 mm	
Cross slide travel	185 mm	
Feed and pitches		
Longitudinal feed within the range	0.014 - 0.38 mm/rev (26 feeds)	
Cross feed within	0.052 - 1.392 mm/rev (32 feeds)	
Pitch - metric in range	0.4 - 7 mm/rev (32 pitches)	
Pitch - inch in range	56 - 4 turns/inch (31 pitches)	
Tailstock		
Tailstock seat	MT 4	
Spindle sleeve diameter / stroke	Ø 50 mm / 110 mm	
Dimensions		
Length x width x height	1 935 / 780 / 1 740 mm	
Weight	500 kg	

Lathe chuck	Art no.
BISON three-jaw lathe chuck Ø 200 mm no. 5 Centrally clamping (chuck flange 3450212 required)	3450210
BISON four-jaw lathe chuck Ø 250 mm no. 5 Centrally clamping (chuck flange 3450218 required)	3450216
› Information about lathe chucks from page 180	

Accessories	Art no.
Spare tool holder 20 x 100 type D for square chisels	3384304
Spare tool holder 30 x 100 type H for round chisels	3384322
Lathe tool set 16 mm, 11-part (see page 186)	3441604
Lathe tool set 16 mm, 5-part (see page 186)	3441668
Lathe tool set 16 mm, 5-part "Made in Germany" (see page 186)	3441216
Lathe tool set 16 mm, 5-part (see page 186)	3441610
Clamping disc Ø 320 mm no. 5	3442979
Vibration-damping machine base SE 2 (6 pcs. required)	3381016
Levelling platen SE 85 (6 pcs. required)	3352982
Position stop with granular adjustment	3441523
› More accessories for lathes from page 184	

*Important information on transport surcharges and „General notes on operating our machines“ on page 249

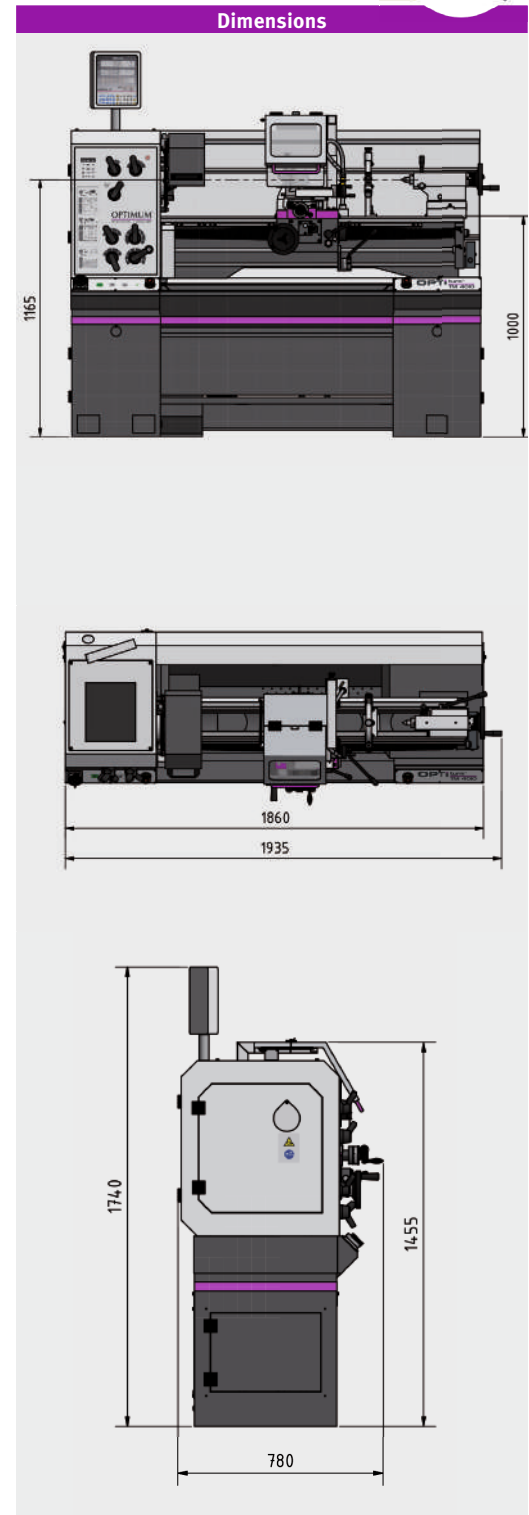

Scope of supply
› Three-jaw lathe chuck Ø 200 mm, no. 5
› Quick change tool holder 3-E
› Fixed steady 7 - 102 mm
› Travelling steady 10 - 60 mm
› Reduction sleeve MT 3 - MT 6
› Fixed centre MT 4
› Machine initially filled with premium grade oil
› Operating tool

Preface

Drilling

Milling

Turning

Saws

Grinding

Polishing

Lamps

Measuring

Fully equipped lathes for mechanics.

TH 3610D with DPA 21 digital position display

Facts that impress in terms of quality, performance and price

- ▶ Tempered and polished z-axis guideway
- ▶ Spindle collet Camlock DIN ISO 702-2 no. 5
- ▶ Precision slide
- ▶ Hand wheels with adjustable fine scaling 0.04 / 0.02 mm
- ▶ Quadruple tool holder
- ▶ All guides adjustable using cleats
- ▶ Main spindle runs in oil bath
- ▶ Gearwheels smooth running, tempered and ground
- ▶ Guaranteed concentricity of spindle nose better than 0.015 mm
- ▶ Gears and shafts tempered and ground, running in oil bath on precision bearings
- ▶ Hand wheels decoupled and approved in line with EN 23125
- ▶ Safety hand wheels with release function in the X and Z axis
- ▶ Two-channel CW/CCW switch approved in line with EN 23125
- ▶ Switch with lifecycle calculation, approved in line with EN ISO 13849
- ▶ Motor circuit breaker, lockable main switch
- ▶ Right-handed/left-handed rotation switchable on bed slide

- ▶ Leading spindle cover
- ▶ Tailstock adjustable ± 10 mm for turning spheres
- ▶ Tailstock spindle sleeve and handwheel with adjustable fine scaling 0.025 mm
- ▶ Fast, easy adjustment without tools thanks to clamping lever
- ▶ Prism bed with strong ribbing, induction tempered and precision ground
- ▶ Machine chassis with tool compartments on both sides
- ▶ Emergency stop device with foot pedal
- ▶ Pull-out chip drawer with guide rails
- ▶ LED machine lamp integrated in chip guard

TH 3610D

▶ Digital position display DPA 21

- › User-friendly membrane keyboard, splash water protected, sealed and dazzle free
- › Glass scales

Control Cabinet

- › 24 Volt DC Power Supply
- › All contactors und relays by Siemens or Schneider



Fig.: TH 3610D - Shown with optional lathe chuck

Technical specifications, accessories and dimensions

Model	TH 3610	TH 3610D
Article no.	3402050	3402060
Technical specifications		
Electrical connection	400 V / 3 Ph ~50 Hz	
Drive motor	1.5 kW	
Spindle		
Spindle taper	MT 6	
Spindle seat	Camlock DIN ISO 702-2 No. 5	
Spindle bore, bar passage diameter	Ø 52 mm	
Quadruple tool holder mounting height	max. 16 mm	
Work area		
Centre height	180 mm	
Centre width	980 mm	
Swing Ø over machine bed	356 mm	
Swing in the bed bridge	516 mm	
Turning length in bed bridge	160 mm	
Swing over cross slide	225 mm	
Bed width	187 mm	
Speed range		
Spindle speed	70 - 2 000 rpm	
Number of speeds	8 speeds	
Travel		
Top slide travel	100 mm	
Cross slide travel	170 mm	
Feeds and pitches		
Longitudinal feed within the range	0.052 - 1.392 mm/rev (32 feeds)	
Cross feed within	0.014 - 0.38 mm/rev (32 feeds)	
Pitch - metric in range	0.4 - 7 mm/rev (26 pitches)	
Pitch - inch in range	56 - 4 turns/inch (34 pitches)	
Tailstock		
Tailstock seat	MT 3	
Tailstock spindle sleeve diameter / stroke	Ø 42 mm / 120 mm	
Dimensions		
Length x width x height	1 930 x 725 x 1 350 / 1 620 mm	
Weight	610 kg	

Lathe chuck	Art no.
OPTIMUM Four-jaw lathe chuck Ø 200 mm no. 5, centric	3442845
OPTIMUM Four-jaw lathe chuck Ø 200 mm no. 5, individual	3442880
BISON three-jaw lathe chuck Ø 200 mm no. 5, centric	3450315
BISON Four-jaw lathe chuck Ø 200 mm no. 5, centric	3450365

> Information about lathe chucks from page 180

Accessories	Art no.
Quick change tool holder SWH 3-E	3384303
Factory assembly SWH 3-E	9000400
Spare tool holder 20 x 100 type D for square chisels	3384304
Spare tool holder 30 x 100 type H for round chisels	3384322
Lathe tool set 16 mm, 11-part (see page 186)	3441604
Lathe tool set 16 mm, 5-part (see page 186)	3441668
Lathe tool set 16 mm, 5-part "Made in Germany" (see page 186)	3441216
Lathe tool set 16 mm, 5-part (see page 186)	3441610
Collet chuck 5C	3441555
Collet kit 3 - 25 mm, 5C, 17-part	3441509
Vibration damping machine base SE 2 (6 pcs. required)	3381016
Levelling platen SE 85 (6 pcs. required)	3352982
Position stop with granular adjustment	3441523

> More accessories for lathes from page 184

*Important information on transport surcharges and „General notes on operating our machines“ on page 249

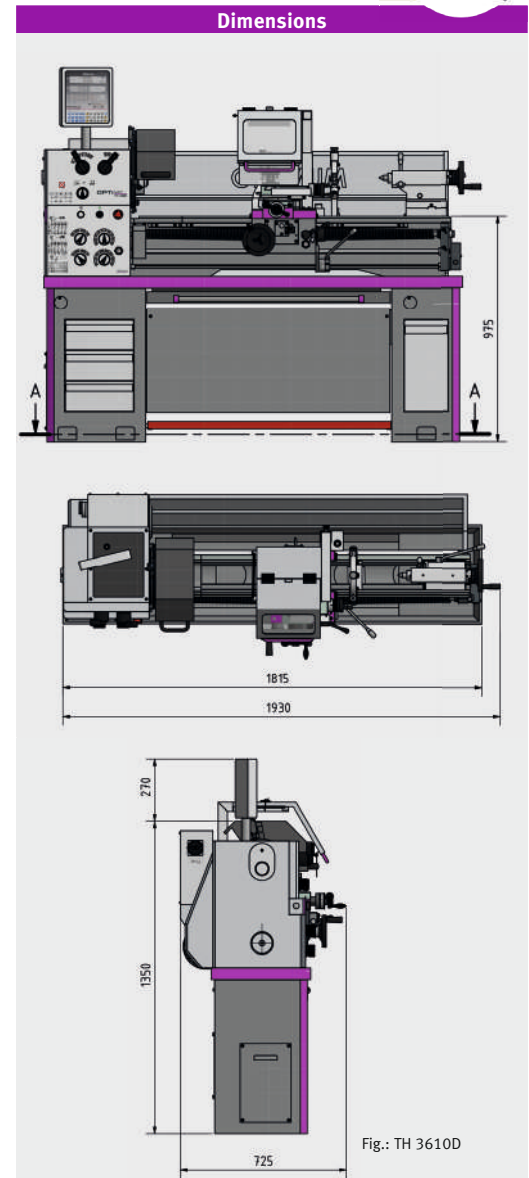

Remember to order a lathe chuck

Scope of supply

- > Steady rest passageway max. Ø 100 mm
- > Follow rest passageway max. Ø 95 mm
- > LED machine lamp
- > Reduction sleeve MT 6 - MT 3
- > One fixed and one alloyed centre MT 3
- > Quadruple tool holder
- > Replaceable gear set
- > Machine chassis
- > Machine initially filled with premium grade oil
- > Operating tool

Preface

Drilling

Milling

Turning

Saws

Grinding

Polishing

Lamps

Measuring

Fully equipped leading and feed spindle lathes.

TH 3309D with digital position display DPA 21, TH 3309V with brushless motor for continuously variable speed control and digital position display DPA 21

Facts that impress in terms of quality, performance and price

- ▶ Tempered and polished z-axis guideway
- ▶ Spindle collet Camlock DIN ISO 702-2 no. 4
- ▶ Precision slide
- ▶ Hand wheels with adjustable fine scaling 0.04 / 0.02 mm
- ▶ Quadruple tool holder
- ▶ All guides adjustable using cleats
- ▶ Main spindle runs in oil bath
- ▶ Gearwheels smooth running, tempered and ground
- ▶ Adjustment range top slide $\pm 90^\circ$
- ▶ Guaranteed concentricity of spindle nose better than 0.015 mm
- ▶ Hand wheels decoupled and approved in line with EN 23125
- ▶ Safety hand wheels with release function in the X and Z axis
- ▶ Two-channel CW/CCW switch approved in line with EN 23125
- ▶ DC 24-Volt electric system with two-channel safety circuit as per EN 23125
- ▶ Chuck protection approved in line with EN 23125
- ▶ Switch with lifecycle calculation, approved in line with EN ISO 13849
- ▶ Lockable main switch
- ▶ Right-handed/left-handed rotation switchable on bed slide
- ▶ Leading spindle cover
- ▶ Tailstock adjustable ± 10 mm for turning spheres

- ▶ Tailstock spindle sleeve and handwheel with adjustable fine scaling 0.02 mm
- ▶ Fast, easy adjustment without tools thanks to clamping lever
- ▶ Prism bed with strong ribbing, induction tempered and precision ground
- ▶ Machine chassis with tool compartment on right-hand side (left side with 3 covers (no compartments))
- ▶ Pull-out chip drawer with guide rails
- ▶ Emergency stop device with foot pedal
- ▶ LED machine lamp integrated in chip guard

TH 3309D / TH 3309V

▶ Digital position display DPA 21

- › User-friendly membrane keyboard, splash water protected, sealed and dazzle free
- › Glass scales

TH 3309V

- ▶ Smooth action and powerful brushless drive
- ▶ Speed change easily adjustable via potentiometer



TU 3309V

Powerful brushless drive

- Particularly smooth action
- › Virtually constant torque over the entire speed range
 - › Extremely powerful



Control Cabinet

- 24 Volt DC Power Supply
- › All contactors und relays by Siemens or Schneider - TH 3309V by Eaton



Fig.: TH 3309D - Shown with optional lathe chuck

Technical specifications, accessories and dimensions

Model	TH 3309	TH 3309 D	TH 3309 V
Article no.	3402030	3402040	3402045
Technical specifications			
Electrical connection	400 V/3 Ph	230 V/1 Ph	
Drive motor	1.5 kW	2.2 kW	
Spindle			
Spindle taper	MT 5		
Spindle seat	Camlock DIN ISO 702-2 No. 4		
Spindle bore, bar passage diameter	Ø 38 mm		
Quadruple tool holder mounting height	16 mm		
Work area			
Centre height	165 mm		
Centre width	830 mm		
Swing Ø over machine bed	330 mm ⁽¹⁾		
Swing in the bed bridge	448 mm		
Turning length in bed bridge	196 mm		
Swing over cross slide	208 mm		
Speed range			
Spindle speed	70 - 2 000 rpm	15 - 2 250 rpm	
Number of speeds	16 speeds	8 speed, electrically controlled	
Travel			
Top slide travel	98 mm		
Cross slide travel	164 mm		
Feeds and pitches			
Longitudinal feed within the range	0.052 - 1.392 mm/rev (32 feeds)		
Cross feed within	0.014 - 0.38 mm/rev (32 feeds)		
Pitch - metric in range	0.4 - 7 mm/rev (26 pitches)		
Pitch - inch in range	56 - 4 turns/inch (34 pitches)		
Tailstock			
Tailstock seat	MT 3		
Tailstock- sleeve diameter/ sleeve travel	Ø 32 mm/110 mm		
Dimensions			
Length x width x height	1 685 x 745 x 1 320 / 1 590 mm		
Weight	430 kg		

Lathe chuck	Art no.
OPTIMUM three-jaw lathe chuck Ø 200 mm no. 4, centric	3442762
OPTIMUM Four-jaw lathe chuck Ø 200 mm no. 4, centric	3442843
OPTIMUM Four-jaw lathe chuck Ø 200 mm no. 4, individual	3442879
BISON three-jaw lathe chuck Ø 160 mm no. 4, centric	3450305
BISON three-jaw lathe chuck Ø 200 mm no. 4, centric	3450310
BISON Four-jaw lathe chuck Ø 160 mm no. 4, centric	3450355
BISON Four-jaw lathe chuck Ø 200 mm no. 4, centric	3450360

> Information about lathe chucks from page 180

Accessories	Art no.
Quick change tool holder SWH 3-E	3384303
Factory assembly SWH 3-E	9000400
Lathe tool set 16 mm, 5-part "Made in Germany" (see page 186)	3441216
Lathe tool set 16 mm, 5-part (see page 186)	3441610
Collet chuck 5 C	3441554

> More accessories for lathes from page 184

*Important information on transport surcharges and „General notes on operating our machines“ on page 249

**The lathe (frequency converter) complies with the DIN EN 55011 standard: class C2 - Note for operation with frequency converter on page 249

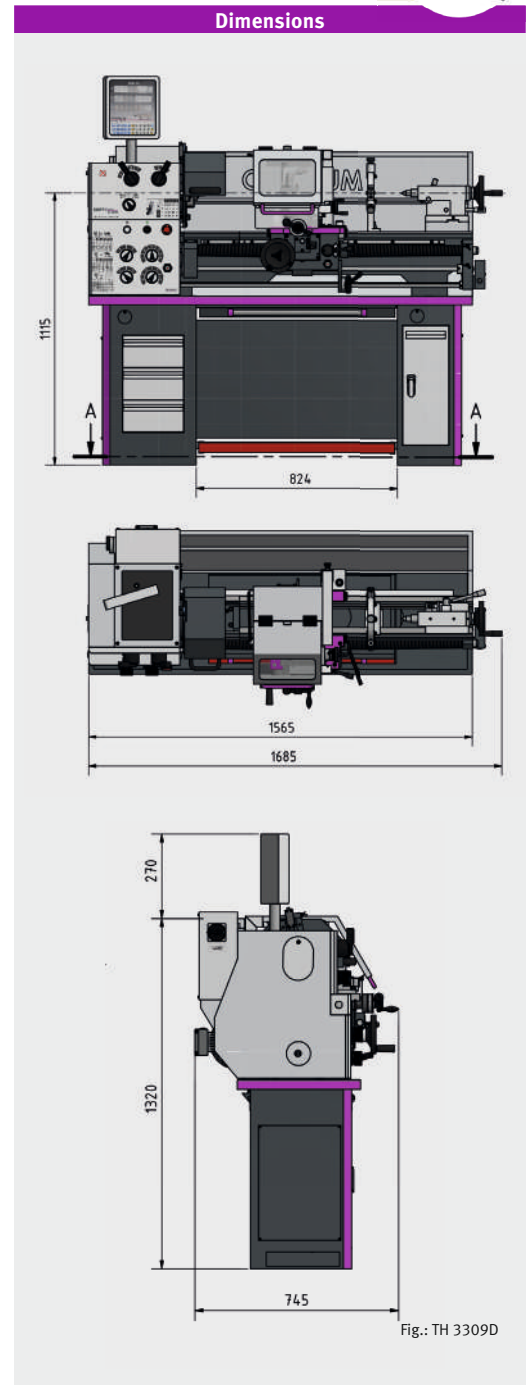

Remember to order a lathe chuck

Scope of supply

- > Steady rest passageway Ø 19 - 70 mm
- > Follow rest passageway Ø 16 - 50 mm
- > LED machine lamp
- > Reduction sleeve MT 5 - MT 3
- > Two fixed centres MT 3
- > Quadruplicate tool holder 16 mm
- > Replaceable gear set
- > Machine chassis
- > Machine initially filled with premium grade oil
- > Operating tool

Preface

Drilling

Milling

Turning

Saws

Grinding

Polishing

Lamps

Measuring

Leading and feed spindle lathes with longitudinal and cross feed.

TU 3008G with gearbox.

TU 3008V with brushless motor for continuously variable speed control

Facts that impress in terms of quality, performance and price

- ▶ Precision workmanship
- ▶ Ribbed grey cast steel prism bed with strong ribbing, induction tempered and precision ground
- ▶ Tempered and polished z-axis guideway
- ▶ Free moving feed gear with rounded gear wheels running in an oil bath
- ▶ Guaranteed concentricity of spindle nose better than 0.009 mm
- ▶ Concentricity at chuck better than 0.04 mm
- ▶ Quadruple tool holder
- ▶ All guides adjustable using cleats
- ▶ Right-handed/left-handed rotation switchable via control panel
- ▶ Tempered main spindle borne on adjustable precision taper roller bearings
- ▶ Tapered roller bearings in P5 quality
- ▶ Tempered spindle nose
- ▶ Large spindle bore Ø 38 mm
- ▶ Leading spindle for thread tapping or automatic longitudinal turning
- ▶ Leading and feed spindles borne on two sintered bearings
- ▶ Automatic longitudinal/cross feeds
- ▶ Feed and lead spindle cover
- ▶ Tailstock adjustable ± 5 mm for turning spheres
- ▶ Tailstock spindle sleeve and handwheel with adjustable fine scaling 0.02 mm
- ▶ Fast, easy adjustment without tools thanks to clamping lever
- ▶ Handwheels on slide with adjustable fine scaling 0.04 / 0.01 mm
- ▶ Interchangeable gears in standard scope of delivery for thread tapping
- ▶ Emergency stop button

TU 3008

- ▶ V-belt

TU 3008G

- ▶ Gearbox

TU 3008V

- ▶ V-belt and brushless drive
- ▶ Smooth action, powerful, brushless DC drive with excellent control characteristics
- ▶ High-precision steel chuck for higher speeds
- ▶ Digital speed display

TU 3008V

Powerful brushless drive

- › Particularly smooth action
- › Virtually constant torque over the entire speed range
- › Extremely powerful

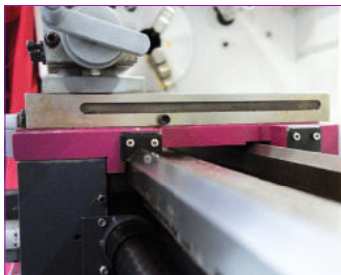

- › Prepared for mounting of measuring system on X, Z and Z0 axis



Fig.: TU 3008V with optional chassis

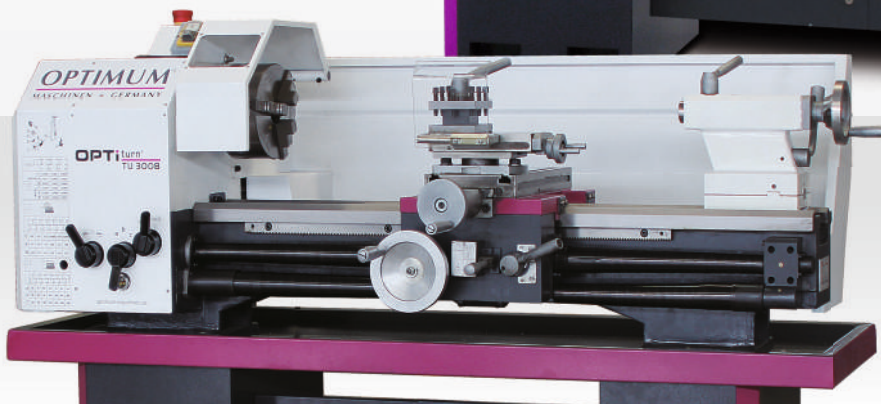

Fig.: TU 3008

Accessories
Machine chassis
Art. no. 3440409

Vibration dampers machine base SE 1
(6 pcs. needed)
Art. no. 3381012

Levelling platen SE 55
(6 pcs. needed)
Art. no. 3352981

Technical specifications, accessories and dimensions

Model	TU 3008	TU 3008G	TU 3008V**
Article no.	3427200	3427210	3427205
Technical specifications			
Electrical connection	400 V / 3 Ph ~50 Hz		230 V / 1 Ph
Drive motor	1.1 kW	1.5 kW	
Spindle			
Spindle taper	MT 5		
Spindle seat	Camlock DIN ISO 702-2 No. 4		
Spindle bore, bar passage diameter	Ø 38 mm		
Quadruple tool holder mounting height	25 mm		
Work area			
Centre height	158 mm		
Centre width	800 mm	720 mm	800 mm
Swing Ø over machine bed	310 mm		
Swing over cross slide	190 mm		
Bed width	180 mm		
Speed range			
Spindle speed TU 3008	150 - 2 000 rpm / 6 speeds		
Spindle speed TU 3008G	165 - 2 400 rpm 6 speeds		
Spindle speed TU 3008V	30 - 3 000 rpm 5 speeds, electronically controlled		
Travel			
Top slide travel	65 mm		
Cross slide travel	150 mm		
Feeds and pitches			
Longitudinal feed within the range	0.085 - 0.832 mm/rev (9 feeds)		
Cross feed within	0.01 - 0.1 mm/rev (9 feeds)		
Pitch - metric in range	0.2 - 3.5 mm/rev (18 pitches)		
Pitch - inch in range	56 - 8 turns/inch (21 pitches)		
Tailstock			
Tailstock seat	MT 3		
Tailstock quill diameter/stroke	Ø 38 mm / 70 mm		
Dimensions			
Length x width x height	1 525 x 705 x 575 mm		
Weight	226 kg	261 kg	243 kg

Lathe chuck	Art no.
OPTIMUM Four-jaw lathe chuck Ø 160 mm no. 4, centric clamping	3442840
BISON Four-jaw lathe chuck Ø 160 mm no. 4, centric clamping	3450355

> Information about lathe chucks from page 180

Accessories	Art no.
Follow rest passageway max. Ø 6 - 60 mm	3441460
Steady rest passageway Ø 6 - 60 mm	3441461
Quick change tool holder SWH 1-A	3384301
Factory assembly SWH 1-A	9000400
Spare tool holder 20 x 90 type D for square chisels	3384302
Spare tool holder 20 x 85 type H for round chisels	3384321
Lathe tool set 16 mm, 11-part (see page 186)	3441604
Lathe tool set 16 mm, 5-part (see page 186)	3441668
Lathe tool set 16 mm, 5-part (see page 186)	3441610
Lathe tool set 16 mm, 5-part "Made in Germany"	3441216
Collet kit 3 - 25 mm, 5C, 17-part	3441509
Collet chuck 5C - Camlock no. 4	3441554
Clamping block set 16-05	3440653

> More accessories for lathes from page 184

*Important information on „General notes on operating our machines“ on page 249
 **The lathe (frequency converter) complies with the DIN EN 55011 standard: class C3

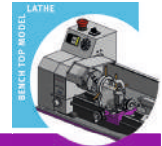

Dimensions

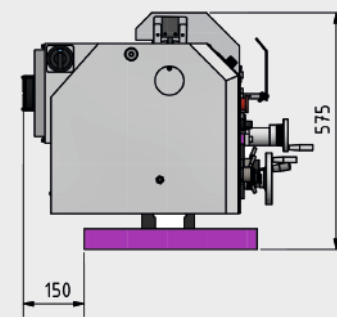
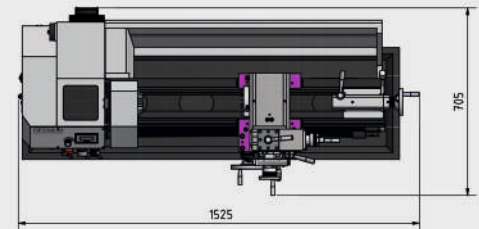
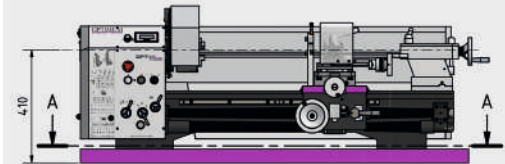

Scope of supply

- > Three-jaw lathe chuck Ø 160 mm, centre clamping
- > Fixed centre MT 3 and MT 5
- > Splashguard
- > Chip tray
- > Quadruplicate tool holder 25 mm
- > Replaceable gear set
- > Operating tool

Accessories

Accessories	Art no.
Digital position display DRO 5 incl. 3 magnetic sensors	3383975
Magnetic strip length 1 100 mm	3383978
Assembly kit (holders for the X / Y and Z0 axis/set of screws)	3383985
Factory assembly	9000420

> Information about position on page 248



Preface

Drilling

Milling

Turning

Saws

Grinding

Polishing

Lamps

Measuring

Leading spindle lathes with feed gear for demanding users.

TU 2807V with brushless motor for continuously variable speed control

Facts that impress in terms of quality, performance and price

- ▶ Precision workmanship
- ▶ Powerful motor, low-maintenance motor
- ▶ Ribbed grey cast steel prism bed with strong ribbing, induction tempered and precision ground
- ▶ Free moving feed gear with rounded gear wheels running in an oil bath
- ▶ Tempered and polished z-axis guideway
- ▶ Guaranteed concentricity of spindle nose better than 0.009 mm
- ▶ Concentricity at chuck better than 0.04 mm
- ▶ Automatic longitudinal/leading spindle drive
- ▶ Leading spindle for thread tapping or automatic longitudinal turning
- ▶ Quadruple tool holder
- ▶ All guides adjustable using cleats
- ▶ Right-handed/left-handed rotation switchable via control panel
- ▶ Tempered main spindle borne on adjustable precision taper roller bearings
- ▶ Tapered roller bearings in P5 quality
- ▶ Tempered spindle nose with Ø 26 mm spindle bore
- ▶ Roll-milled trapezoidal spindles
- ▶ Chip guard on top slide
- ▶ Top slide displaceable on cross slide
- ▶ Tailstock adjustable ± 5 mm for turning spheres
- ▶ Tailstock spindle sleeve and handwheel with adjustable fine scaling 0.02 mm
- ▶ Fast, easy adjustment without tools thanks to clamping lever
- ▶ Leading spindle borne on two sintered bearings
- ▶ Interchangeable gears in standard scope of delivery for thread tapping
- ▶ Handwheels on slide with adjustable fine scaling 0.04 / 0.01 mm
- ▶ Thrust bearings
- ▶ Three-jaw lathe chuck included in standard scope of delivery
- ▶ Emergency stop button
- ▶ Fully equipped; the user can immediately start productive work after commissioning

TU 2807V

- ▶ Smooth action, powerful, brushless DC drive with excellent control characteristics
- ▶ High-precision steel chuck for higher speeds
- ▶ Speed change easily adjustable via potentiometer
- ▶ Digital speed display

TU 2807V

Powerful brushless drive

- Particularly smooth action
- › Virtually constant torque over the entire speed range
- › Extremely powerful



Accessories

Machine chassis

Art. no. 3440409

Vibration dampers machine base SE 1

(6 pcs. needed)

Art. no. 3381012

Levelling platen SE 55

(6 pcs. needed)

Art. no. 3352981



Fig.: TU 2807V

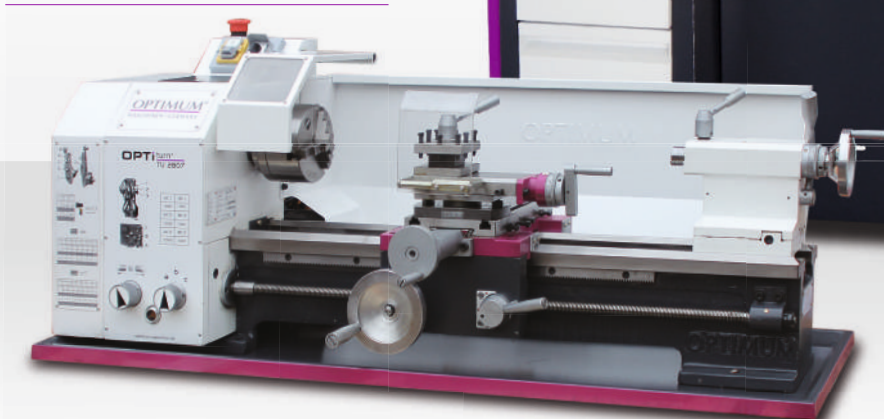

Fig.: TU 2807

Technical specifications, accessories and dimensions

Model	TU 2807	TU 2807V**
Article no. (230 V)	3427001	3427006
Article no. (400 V)	3427003	-
Technical specifications		
Electrical connection	230 V / 1 Ph ~ 50 Hz 400 V / 3 Ph ~ 50 Hz	230 V / 1 Ph ~ 50 Hz
Drive motor	850 W	1.5 kW
Spindle		
Spindle taper	MT 4	
Spindle seat	Short taper	
Spindle bore, bar passage diameter	Ø 26 mm	
Quadruple tool holder height	max. 13.5 mm	
Work area		
Centre height	140 mm	
Centre width	700 mm	
Swing Ø over machine bed	266 mm	
Swing over cross slide	170 mm	
Bed width	180 mm	
Speed range		
Spindle speed	150 - 2 000 rpm	30 - 4 000 rpm
Number of speeds	6 speeds	4 speeds Electronically controlled
Travel		
Top slide travel	60 mm	
Cross slide travel	160 mm	
Feeds and pitches		
Longitudinal feed within the range	0.07 - 0.4 mm/rev (6 feeds)	
Pitch - metric in range	0.2 - 3.5 mm/rev (18 pitches)	
Pitch - inch in range	56 - 8 turns/inch (21 pitches)	
Tailstock		
Tailstock seat	MT 2	
Tailstock quill diameter/stroke	30 mm / 85 mm	
Dimensions		
Length x width x height	1 370 x 640 x 535 mm	1 370 x 660 x 440 mm
Weight	180 kg	

Lathe chucks and accessories	Art no.
Four-jaw lathe chuck Ø 125 mm, individual clamping (Chuck flange 3441312 required)	3442874
Four-jaw lathe chuck Ø 125 mm, centre clamping (Chuck flange 3441312 required)	3442812
Chuck flange for lathe chuck Ø 125 mm (3442874/3442812)	3441312
Three-jaw lathe chuck Ø 160 mm, centre clamping (Chuck flange 3441413 required)	3442716
Four-jaw lathe chuck Ø 160 mm, centre clamping (Chuck flange 3441413 required)	3442816
Chuck flange for lathe chuck Ø 160 mm (3442716/3442816)	3441413
› Information about lathe chucks from page 180	

Accessories	Art no.
Steady rest passageway max. Ø 55 mm	3441415
Follow rest passageway max. Ø 56 mm	3441410
Quick change tool holder SWH 1-A	3384301
Factory assembly SWH 1-A	9000401
Spare tool holder 20 x 90 type D for square chisels	3384302
Spare tool holder 20 x 85 type H for round chisels	3384321
Lathe tool set 10 mm, 11-part (see page 185)	3441602
Lathe tool set 12 mm, 11-part (see page 185)	3441603
Lathe tool set 12 mm, 5-part "Made in Germany"	3441212
Collet kit ER 32, 3 - 20 mm	3441122
Collet chuck ER 25, cylindrical	3441305
Collet chuck ER 32, short taper	3441306
› More accessories for lathes from page 184	

*Important information on „General notes on operating our machines“ on page 249
 **The lathe (frequency converter) complies with the DIN EN 55011 standard: class C3

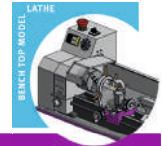

Dimensions

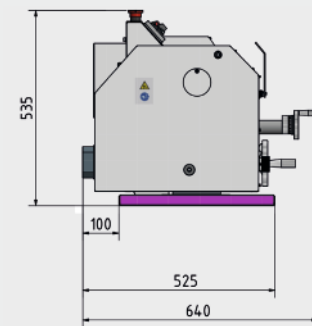
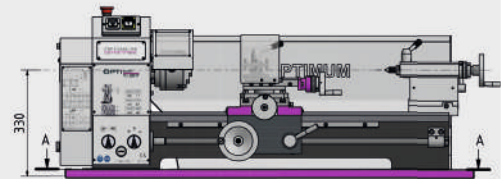
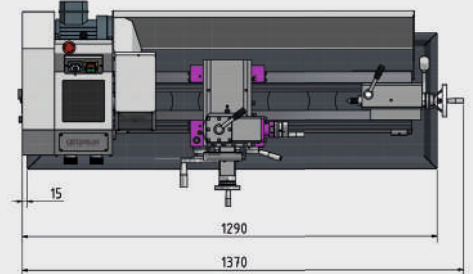

Scope of supply

- › Three-jaw lathe chuck Ø 125 mm, centre clamping
- › Fixed centre MT 2 and MT 4
- › Splashguard
- › Chip tray
- › HSS lathe tools
- › Quadruplicate tool holder 13.5 mm
- › Replaceable gear set
- › Operating tool

Accessories	Art no.
Digital position display DRO 5 incl. 3 magnetic sensors	3383975
Magnetic strip length 1 100 mm	3383978
Factory assembly	9000420
› Information about position display on page 248	



Preface

Drilling

Milling

Turning

Saws

Grinding

Polishing

Lamps

Measuring

Leading spindle lathes with feed gear for demanding users.

TU 2506V with brushless motor for continuously variable speed control

Facts that impress in terms of quality, performance and price

- ▶ Precision workmanship
- ▶ Powerful motor, low-maintenance motor
- ▶ Ribbed grey cast steel prism bed with strong ribbing, induction tempered and precision ground
- ▶ Tempered and polished z-axis guideway
- ▶ Guaranteed concentricity of spindle nose better than 0.009 mm
- ▶ Automatic longitudinal/leading spindle drive
- ▶ Roll-milled trapezoidal spindles
- ▶ Chip guard on top slide
- ▶ Top slide displaceable on cross slide
- ▶ Leading spindle for thread tapping or automatic longitudinal turning
- ▶ Quadruple tool holder
- ▶ All guides adjustable using cleats
- ▶ Concentricity at chuck better than 0.04 mm
- ▶ Right-handed/left-handed rotation switchable via control panel
- ▶ Tempered main spindle borne on adjustable precision taper roller bearings
- ▶ Tapered roller bearings in P5 quality
- ▶ Tempered spindle nose with $\varnothing 26$ mm spindle bore
- ▶ Tailstock adjustable ± 5 mm for turning spheres

- ▶ Tailstock spindle sleeve and handwheel with adjustable fine scaling 0.02 mm
- ▶ Fast, easy adjustment of the tailstock without tools thanks to clamping lever
- ▶ Leading spindle borne on two sintered bearings
- ▶ Handwheels on slide with adjustable fine scaling 0.04 / 0.01 mm
- ▶ Thrust bearings
- ▶ Emergency stop button
- ▶ Three-jaw lathe chuck included in standard scope of delivery
- ▶ Interchangeable gears in standard scope of delivery for thread tapping
- ▶ Fully equipped; the user can immediately start productive work after commissioning

TU 2506 V

- ▶ Smooth action, powerful, brushless DC drive with excellent control characteristics
- ▶ High-precision steel chuck for higher speeds
- ▶ Speed change easily adjustable via potentiometer
- ▶ Digital speed display

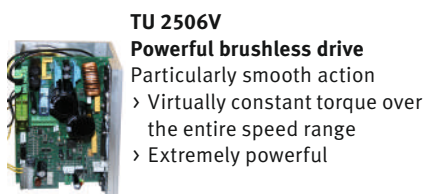

TU 2506V

Powerful brushless drive

- Particularly smooth action
- › Virtually constant torque over the entire speed range
- › Extremely powerful

Accessories

Machine chassis

Art. no. 3440409

Vibration dampers machine base SE 1

(6 pcs. needed)

Art. no. 3381012

Levelling platen SE 55

(6 pcs. needed)

Art. no. 3352981

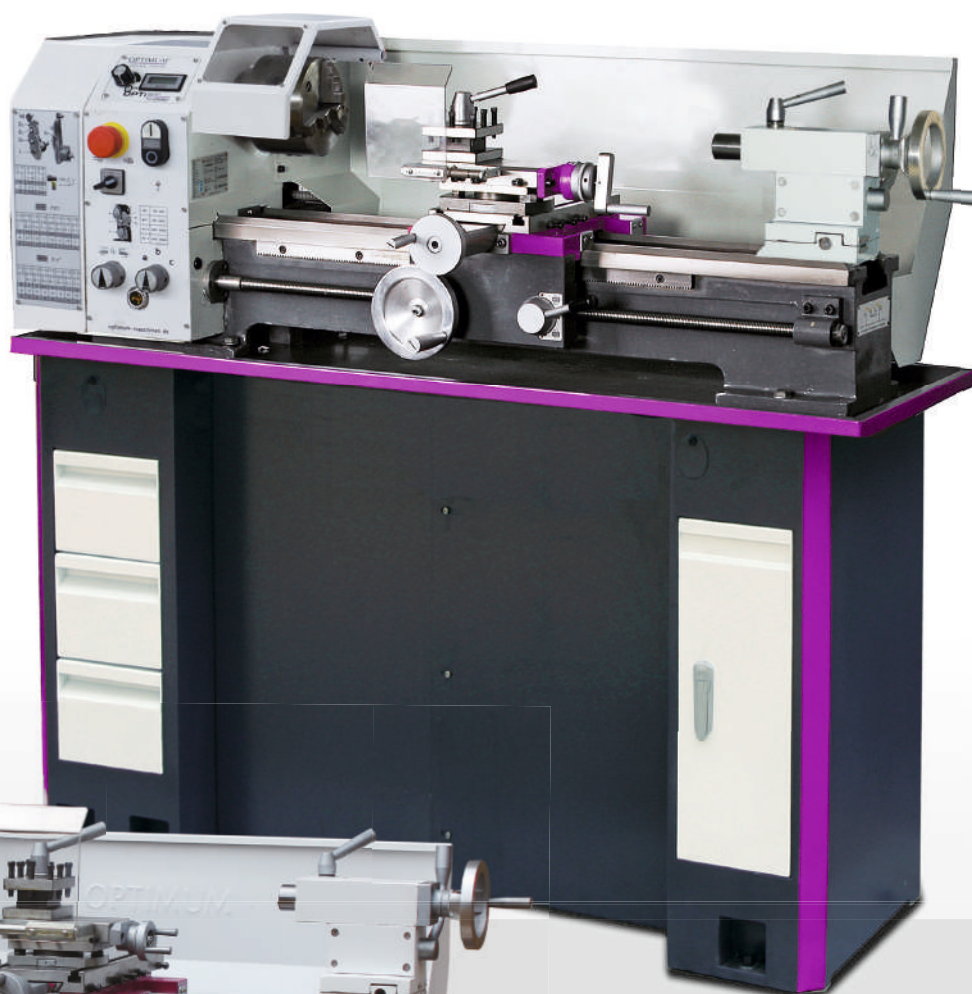

Fig.: TU 2506V

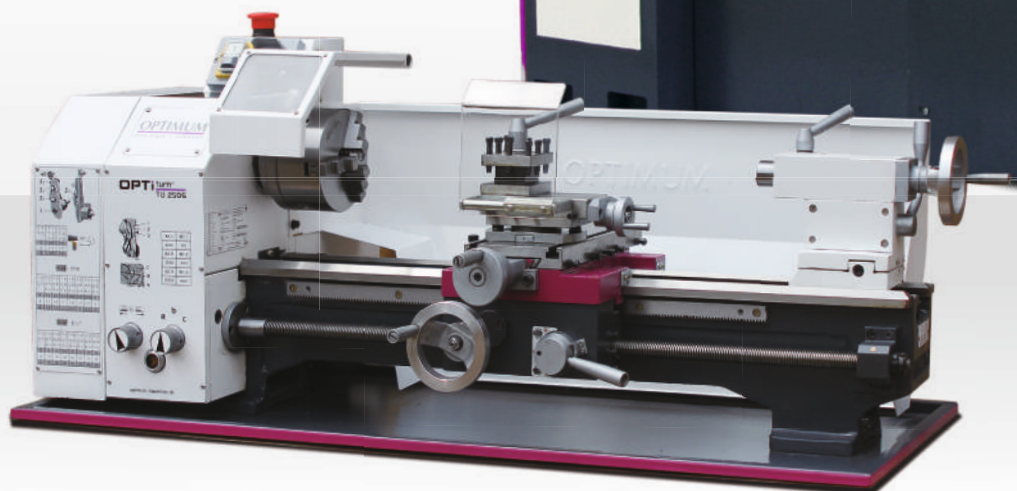

Fig.: TU 2506

Technical specifications, accessories and dimensions

Model	TU 2506	TU 2506V*
Article no. (230 V)	3425001	3425006
Article no. (400 V)	3425003	

Technical specifications		
Electrical connection	230 V / 1 Ph ~ 50 Hz 400 V / 3 Ph ~ 50 Hz	230 V / 1 Ph ~ 50 Hz
Drive motor	750 W	1.5 kW
Spindle		
Spindle taper	MT 4	
Spindle seat	Short taper	
Spindle bore, bar passage diameter	Ø 26 mm	
Quadruple tool holder mounting height	max. 13 mm	
Work area		
Centre height	125 mm	
Centre width	550 mm	
Swing Ø over machine bed	250 mm	
Bed width	135 mm	
Speed range		
Spindle speed	125 - 2 000 rpm	30 - 4 000 rpm 4 speeds
Number of speeds	6 speeds	Electronically controlled
Travel		
Top slide travel	70 mm	
Cross slide travel	110 mm	
Feeds and pitches		
Longitudinal feed within the range	0.07 - 0.4 mm/rev (6 feeds)	
Pitch - metric in range	0.2 - 4 mm/rev (21 pitches)	
Pitch - inch in range	56 - 8 turns/inch (21 pitches)	
Tailstock		
Tailstock seat	MT 2	
Tailstock quill diameter/stroke	30 mm / 65 mm	
Dimensions		
Length x width x height	1 250 x 585 x 475 mm	1 250 x 650 x 420 mm
Weight	125 kg	

Lathe chucks and accessories	Art no.
Four-jaw lathe chuck Ø 125 mm, individual clamping (Chuck flange 3441312 required)	3442874
Four-jaw lathe chuck Ø 125 mm, centre clamping (Chuck flange 3441312 required)	3442812
Chuck flange lathe chuck Ø 125 mm (lathe chuck 3442874/3442812)	3441312
Planar clamping disc Ø 240 mm	3441352
› Information about lathe chucks from page 180	

Accessories	Art no.
Steady rest passageway max. Ø 50 mm	3441315
Follow rest passageway max. Ø 34 mm	3441310
Quick change tool holder SWH 1-A	3384301
Factory assembly SWH 1-A	9000401
Spare tool holder 20 x 90 type D for square chisels	3384302
Spare tool holder 20 x 85 type H for round chisels	3384321
Lathe tool set 10 mm, 11-part (see page 185)	3441602
Lathe tool set 12 mm, 11-part (see page 185)	3441603
Lathe tool set 12 mm, 5-part "Made in Germany"	3441212
Collet kit ER 32, 3 - 20 mm	3441122
Collet chuck ER 25, cylindrical	3441305
Collet chuck ER 32, short taper	3441306
› More accessories for lathes from page 184	

*Important information on transport surcharges and „General notes on operating our machines“ on page 249

**The lathe (frequency converter) complies with the DIN EN 55011 standard: class C3 - Note for operation with frequency converter on page 249

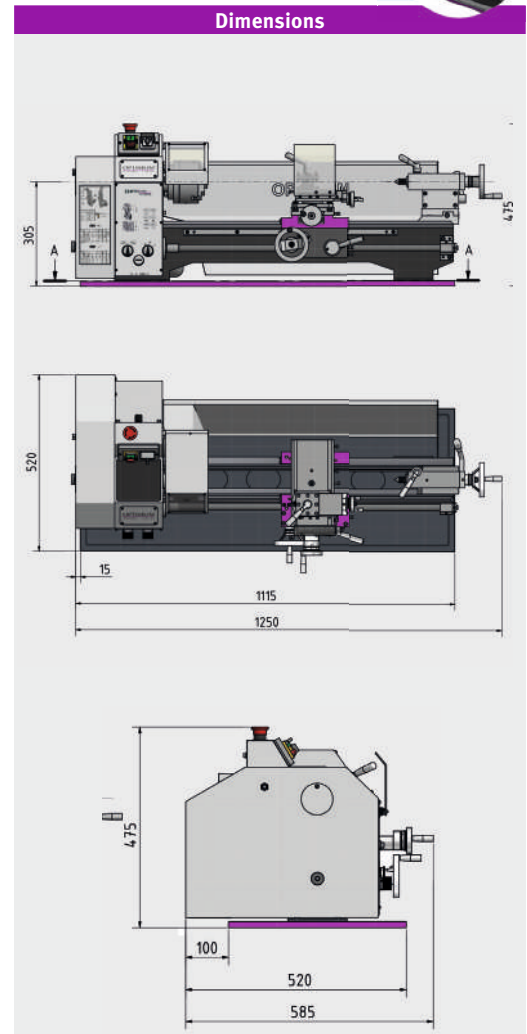
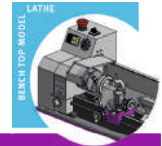

Scope of supply
› Three-jaw lathe chuck Ø 125 mm,
› Centre clamping
› Fixed centre MT 2 and MT 4
› Splashguard
› Chip tray
› HSS lathe tools
› Quadruple tool holder
› Replaceable gear set
› Operating tool

Accessories	Art no.
	
Digital position display DRO 5 incl. 3 magnetic sensors	3383975
Magnetic strip length 1 100 mm	3383978
Factory assembly	9000420
› Information about position display on page 248	

Preface

Drilling

Milling

Turning

Saws

Grinding

Polishing

Lamps

Measuring

Lathes for DIY.

TU 2406V with electronic speed control

Facts that impress in terms of quality, performance and price

- ▶ Precision workmanship
- ▶ Tempered and polished z-axis guideway
- ▶ Guaranteed concentricity of spindle nose better than 0.009 mm
- ▶ Roll-milled trapezoidal spindles
- ▶ Leading spindle borne on two sintered bearings
- ▶ Two tapered roller bearings in P5 quality
- ▶ Precision slide
- ▶ Hand wheels with adjustable fine scaling 0.04 / 0.01 mm
- ▶ Quadruple tool holder
- ▶ All guides adjustable using cleats
- ▶ Chuck concentricity better than 0.05 mm
- ▶ Leading spindle for thread tapping or automatic longitudinal turning
- ▶ Right-handed/left-handed rotation switchable via control panel
- ▶ Tailstock adjustable ± 5 mm for turning spheres
- ▶ Tailstock spindle sleeve and handwheel with adjustable fine scaling 0.02 mm
- ▶ Fast, easy adjustment without tools thanks to clamping lever
- ▶ Emergency stop button
- ▶ Thrust bearings
- ▶ Comprehensive range of accessories
- ▶ Three-jaw lathe chuck included in standard scope of delivery
- ▶ Lasting value

TU 2406 V

- ▶ Speed change easily adjustable via potentiometer
- ▶ Digital speed display
- ▶ EMC filter class C1



Accessories

Machine chassis

Art. no. 3440409

Vibration dampers machine base SE 1

(6 pcs. needed)

Art no. 3381012

Levelling platen SE 55

(6 pcs. needed)

Art no. 3352981

Fig.: TU 2406V with optional machine chassis

Fig.: TU 2406

Technical specifications, accessories and dimensions

Model	TU 2406	TU 2406V**
Article no. (230 V)	3420350	3420355
Article no. (400 V)	3420353	-
Technical specifications		
Electrical connection	230 V / 1 Ph ~ 50 Hz 400 V / 3 Ph ~ 50 Hz	230 V / 1 Ph ~ 50 Hz
Drive motor	750 W	1.1 kW
Spindle		
Spindle taper	MT 3	
Spindle seat	cylindrical Ø 52 mm	
Spindle bore, bar passage diameter	Ø 21 mm	
Quadruple tool holder mounting height	14 mm	
Work area		
Centre height	125 mm	
Centre width	550 mm	
Swing Ø over machine bed	250 mm	
Bed width	135 mm	
Speed range		
Spindle speed	125 - 2 000 rpm	150 - 2 500 rpm
Number of speeds	6 speeds	2-speed, electronic speed control
Travel		
Top slide travel	75 mm	
Cross slide travel	120 mm	
Pitches		
Pitch - metric in range	0.4 - 3.5 mm/rev (14 pitches)	
Pitch - inch in range	44 - 10 turns/inch (12 pitches)	
Tailstock		
Tailstock seat	MT 2	
Tailstock - quill stroke	70 mm	
Dimensions		
Length x width x height	1 090 x 594 x 484 mm	
Weight	125 kg	

Lathe chucks and accessories	Art no.
Four-jaw lathe chuck Ø 125 mm, centre clamping (Chuck flange 3440511 required)	3442812
Four-jaw lathe chuck Ø 125 mm, individual clamping (Chuck flange 3440511 required)	3442874
Chuck flange lathe chuck Ø 125 mm (lathe chuck 3442812/3442874)	3440511
Clamping disc Ø 220 mm	3440552
› Information about lathe chucks from page 180	

Accessories	Art no.
Steady rest passageway max. Ø 50 mm	3441315
Follow rest passageway max. Ø 34 mm	3441310
Quick change tool holder SWH 1-A	3384301
Factory assembly SWH 1-A	9000401
Spare tool holder 20 x 90 type D for square chisels	3384302
Spare tool holder 20 x 85 type H for round chisels	3384321
Lathe tool set 10 mm, 11-part (see page 185)	3441602
Lathe tool set 12 mm, 11-part (see page 185)	3441603
Lathe tool set 12 mm, 5-part (see page 185)	3441666
Lathe tool set 12 mm, 5-part "Made in Germany"	3441212
Information on „Lathe tool set“ from page 186	
Collet chuck ER 25, cylindrical	3440505
Collet chuck ER 32, short taper	3440506
› More accessories for lathes from page 184	

*Important information on „General notes on operating our machines“ on page 249

**The lathe (frequency converter) complies with the DIN EN 55011 standard: class C1 - Note for operation with frequency converter on page 249

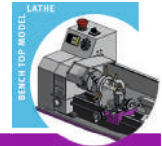

Dimensions

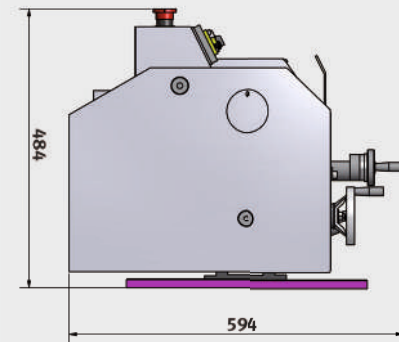
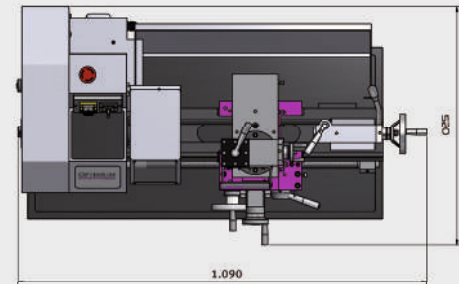

Scope of supply

- › Three-jaw lathe chuck Ø 125 mm,
- › Centre clamping
- › Fixed centre MT 2 and MT 3
- › Splashguard
- › Chip tray
- › Quadruple tool holder
- › Replaceable gear set
- › Operating tool

Accessories

Art no.



Digital position display DRO 5 incl. 3 magnetic sensors	3383975
Magnetic strip length 1 100 mm	3383978
Factory assembly	9000420
› Information about position display on page 248	

Preface

Drilling

Milling

Turning

Saws

Grinding

Polishing

Lamps

Measuring

Lathes for DIY.

TU 2304V with electronic speed control

Facts that impress in terms of quality, performance and price

- ▶ Precision workmanship
- ▶ Grey cast iron prism bed with strong ribbing, aged for at least six months, induction tempered and precision ground
- ▶ Tempered and polished z-axis guideway
- ▶ Guaranteed concentricity of spindle nose better than 0.009 mm
- ▶ Roll-milled trapezoidal spindles
- ▶ Leading spindle borne on two sintered bearings
- ▶ All guides adjustable using cleats
- ▶ Precision slide
- ▶ Hand wheels with adjustable fine scaling 0.04 / 0.01 mm
- ▶ Quadruple tool holder
- ▶ Chuck concentricity better than 0.05 mm
- ▶ Leading spindle for thread tapping or automatic longitudinal turning
- ▶ Right-handed/left-handed rotation switchable via control panel
- ▶ Tailstock adjustable ± 5 mm for turning spheres
- ▶ Tailstock spindle sleeve and handwheel with adjustable fine scaling 0.02 mm
- ▶ Fast, easy adjustment without tools thanks to clamping lever
- ▶ Emergency stop button
- ▶ Chuck protection
- ▶ Thrust bearings
- ▶ Interchangeable gear set for thread tapping
- ▶ Comprehensive range of accessories
- ▶ Three-jaw lathe chuck included in standard scope of delivery
- ▶ Lasting value

TU 2304 V

- ▶ Speed change easily adjustable via potentiometer
- ▶ Digital speed display
- ▶ EMC filter class C1



Accessories

Machine chassis

Art. no. 3440409

Vibration dampers machine base SE 1

(6 pcs. needed)

Art. no. 3381012

Levelling platen SE 55

(6 pcs. needed)

Art. no. 3352981

Fig. similar: TU 2304V with optional machine chassis

Technical specifications, accessories and dimensions

Model	TU 2304	TU 2304V**
Article no.	3420320	3420325
Technical specifications		
Electrical connection	230 V / 1 Ph ~50 Hz	
Drive motor	750 W	
Spindle		
Spindle taper	MT 3	
Spindle seat	cylindrical Ø 72 mm	
Spindle bore, bar passage diameter	Ø 20 mm	
Quadruple tool holder mounting height	14 mm	
Work area		
Centre height	115 mm	
Centre width	450 mm	
Swing Ø over machine bed	230 mm	
Bed width	135 mm	
Speed range		
Spindle speed	125 - 2 000 rpm	150 - 2 200 rpm
Number of speeds	6 speeds	2 speeds, electronically controlled
Travel		
Top slide travel	75 mm	
Cross slide travel	120 mm	
Pitches		
Pitch - metric in range	0.4 - 3.5 mm/rev (14 pitches)	
Pitch - inch in range	44 - 8 turns/inch (14 pitches)	
Tailstock		
Tailstock seat	MT 2	
Tailstock - quill stroke	70 mm	
Dimensions		
Length x width x height	965 x 585 x 510 mm	
Weight	111 kg	114 kg

Lathe chucks and accessories	Art no.
Three-jaw lathe chuck Ø 125 mm, centre clamping (Chuck flange 3440313 required)	3442712
Four-jaw lathe chuck Ø 125 mm, centre clamping (Chuck flange 3440313 required)	3442812
Four-jaw lathe chuck Ø 125 mm, individual clamping (Chuck flange 3440313 required)	3442874
Chuck flange for lathe chuck Ø 125 mm	3440313
› Information about lathe chucks from page 180	

Accessories	Art no.
Steady rest passageway max. Ø 55 mm	3440361
Follow rest passageway max. Ø 34 mm	3440360
Quick change tool holder SWH 1-A	3384301
Factory assembly SWH 1-A	9000401
Spare tool holder 20 x 90 type D for square chisels	3384302
Spare tool holder 20 x 85 type H for round chisels	3384321
Lathe tool set 10 mm, 11-part (see page 185)	3441602
Lathe tool set 12 mm, 11-part (see page 185)	3441603
Lathe tool set 12 mm, 5-part "Made in Germany"	3441212
Information on „Lathe tool set“ from page 186	
Travelling centre MT 2	3440702
Collet chuck ER 25 Ø 72 mm	3440305
Clamping disc Ø 170 mm	3440295
› More accessories for lathes from page 184	

*Important information on transport surcharges and „General notes on operating our machines“ on page 249

**The lathe (frequency converter) complies with the DIN EN 55011 standard: class C1 - Note for operation with frequency converter on page 249

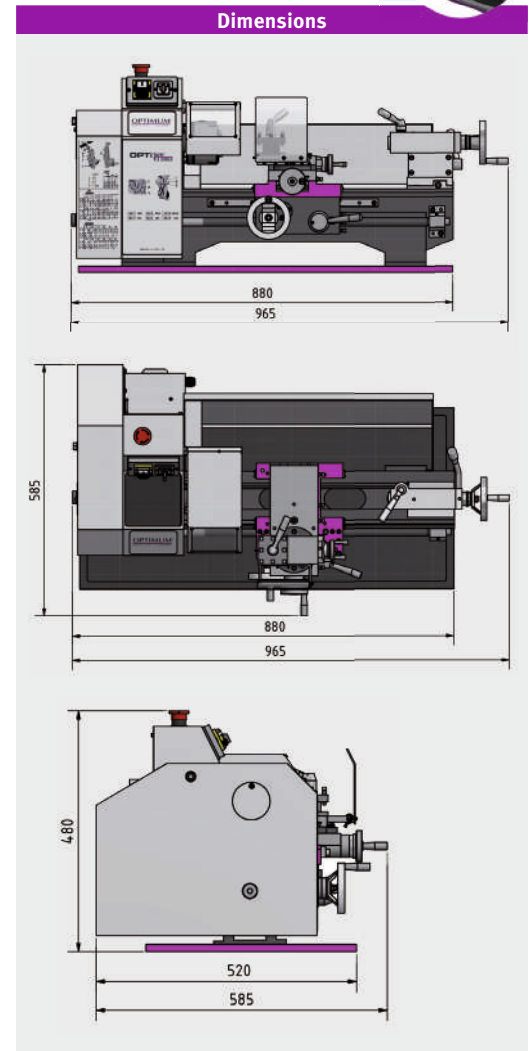
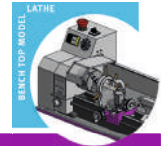

Scope of supply
› Three-jaw lathe chuck Ø 100 mm,
› Centre clamping
› Fixed centre MT 2 and MT 3
› Splashguard
› Chip tray
› Quadruple tool holder
› Replaceable gear set
› Operating tool

Accessories	Art no.
Digital position display DRO 5 incl. 3 magnetic sensors	3383975
Magnetic strip length 1 100 mm	3383978
Factory assembly	9000420
› Information about position display on page 248	



Preface

Drilling

Milling

Turning

Saws

Grinding

Polishing

Lamps

Measuring

Modelbuilding lathe with electronic speed control and digital speed display

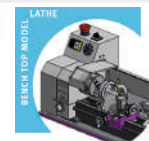

Facts that impress in terms of quality, performance and price

- ▶ Precision workmanship
- ▶ Ribbed cast steel prism bed with strong ribbing, induction tempered and precision ground
- ▶ Tempered and polished z-axis guideway
- ▶ Tempered spindle nose (DIN 6350)
- ▶ Guaranteed concentricity of spindle nose better than 0.009 mm
- ▶ Automatic longitudinal/leading spindle drive
- ▶ Roll-milled trapezoidal thread on lead spindle
- ▶ Leading spindle borne on two sintered bearings
- ▶ Longitudinal, cross and top slides
- ▶ Right-handed/left-handed rotation switchable via control panel
- ▶ Tempered main spindle borne on adjustable precision taper roller bearings
- ▶ Tapered roller bearings in P5 quality
- ▶ Cylindrical centring mount
- ▶ Tempered spindle nose with Ø 21 mm spindle bore
- ▶ Lathe chuck concentricity better than 0.04 mm
- ▶ Tailstock adjustable for turning spheres
- ▶ Tailstock spindle sleeve and handwheel with adjustable fine scaling 0.02 mm
- ▶ Fast, easy adjustment without tools thanks to clamping lever
- ▶ Emergency stop button
- ▶ Chuck protection
- ▶ Thrust bearings
- ▶ Gearbox with interchangeable gearwheels
- ▶ Quadruple tool holder, rotating
- ▶ Interchangeable gear set as standard enables large thread tapping area
- ▶ Three-jaw lathe chuck included in standard scope of delivery
- ▶ EMC filter class C1

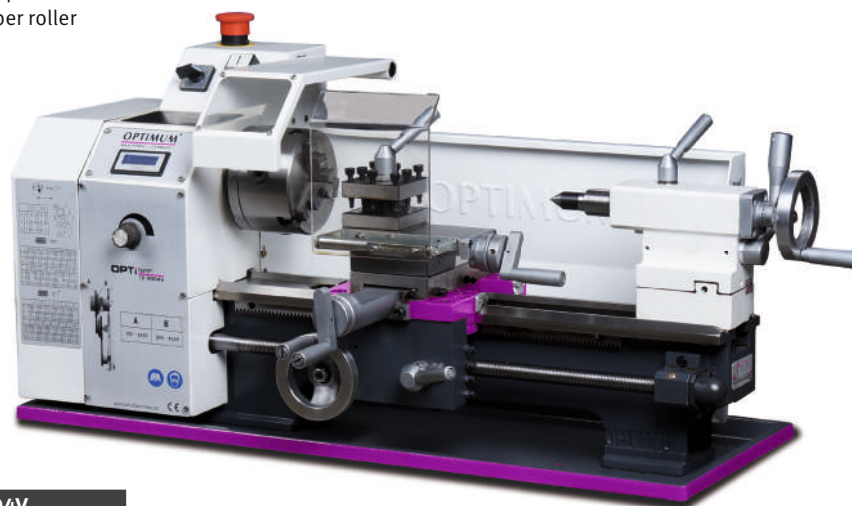

Model	TU 2004V
Article no.	3420310

Technical specifications	
Electrical connection	230 V / 1 Ph ~ 50 Hz
Drive motor	600 W
Spindle	
Spindle taper	MT 3
Spindle bore	Ø 21 mm
Spindle seat	cylindrical Ø 72 mm
Passageway three-jaw chuck	Ø 20 mm
Quadruple tool holder mounting height	12 mm
Work areas	
Centre height	100 mm
Centre width	300 mm
Max. turning diameter	200 mm*
Swing over cross slide	110 mm
Bed width	100 mm
Speed range	
Spindle speeds	150 - 2 500 rpm
Number of speeds	2 speeds. Electronic speed control
Travel	
Top slide travel	55 mm
Cross slide travel	75 mm
Feed and pitches	
Longitudinal feed within the range	0.1 - 0.2 mm/rev (2 feeds)
Pitch - metric in range	0.25 - 3 mm/rev (14 pitch)
Pitch - inch in range	44 - 8 turns/inch (12 pitches)
Tailstock	
Tailstock seat	MT 2
Tailstock - quill stroke	65 mm
Dimensions L x H x W	
Weight	830 x 425 x 360 mm 61 kg

Scope of supply	
>	Three-jaw lathe chuck Ø 100 mm, centre clamping
>	Fixed centre MT 2 and MT 3
>	Splashguard
>	Chip tray
>	Replaceable gear set
>	Quadruple tool holder
>	Operating tool

Lathe chuck	Art. no.
Four-jaw lathe chuck Ø 100 mm, centre clamping (Chuck flange 3440312 required)	3442810
Four-jaw lathe chuck Ø 100 mm, individual clamping (Chuck flange 3440312 required)	3442872
Chuck flange for lathe chuck Ø 100 mm (3442810/3442872)	3440312
Clamping disc Ø 170 mm	3440295
> Information about lathe chucks from page 180	

Accessories	Art. no.
Follow rest passageway max. Ø 40 mm	3440230
Steady rest passageway max. Ø 50 mm	3440231
Collet chuck ER 25 Ø 72 mm	3440305
Quick change tool holder SWH-AA	3384311
Factory assembly SWH-AA	9000401
Spare tool holder 12 x 50 type D for square chisels	3384312
Spare tool holder 12 x 50 type H for round chisels	3384320
Lathe tool set 10 mm, 11-part	3441602
Lathe tool set 10 mm, 5-part	3441664

Information on „Lathe tool set“ from page 186

> More accessories for lathes from page 184

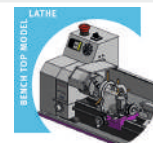

The small-scale lathe with electronically controllable speed

Facts that impress in terms of quality, performance and price

- ▶ Direct current motor
- ▶ Ribbed grey cast prism bed, induction tempered and ground
- ▶ Tempered and polished z-axis guideway
- ▶ Guaranteed concentricity of spindle nose better than 0.015 mm
- ▶ Chuck concentricity max. 0.05 mm
- ▶ Leading spindle for thread tapping or automatic longitudinal turning
- ▶ Longitudinal, cross and top slides
- ▶ Automatic longitudinal/leading spindle drive
- ▶ Large thread tapping area thanks to interchangeable gear set
- ▶ Three-jaw lathe chuck included in standard scope of delivery
- ▶ Fast and easy speed change through V-belt
- ▶ Safety switch in cover
- ▶ Right-handed/left-handed rotation switchable via control panel
- ▶ Chuck protection with microswitch
- ▶ Hand wheels with adjustable fine scaling 0.04 / 0.01 mm
- ▶ All guides adjustable without play using cleats
- ▶ Emergency stop button
- ▶ Low-voltage electronics
- ▶ EMC filter class C1



Model	TU 1503V
Article no.	3420260
Technical specifications	
Electrical connection	230 V / 1 Ph ~50 Hz
Drive motor	450 W
Spindle	
Spindle taper	MT 1
Spindle bore	Ø 11 mm
Spindle seat	cylindrical Ø 22 mm
Dual tool holder chuck height	12 mm
Work areas	
Centre height	75 mm
Centre width	265 mm
Max. turning diameter	150 mm*
Bed width	70 mm
Speed range	
	120 - 3 000 rpm
Number of speeds	Electronic speed control
Travel	
Top slide travel	40 mm
Cross slide travel	55 mm
Feed and pitch	
Longitudinal feed within the range	0.05 - 0.1 mm/rev (2 feeds)
Metric pitch	0.5 - 1.5 mm/rev (8 pitches)
Tailstock	
Tailstock seat	MT 1 short
Tailstock - quill stroke	30 mm
Dimensions L x W x H	
	570 x 340 x 300 mm
Weight	23 kg

Scope of supply
> Three-jaw lathe chuck Ø 80 mm, centre clamping
> Fixed centre MT 1
> Splashguard
> Chip tray
> Replaceable gear set
> Dual tool holder
> Operating tool

Lathe chuck	Article no.
Three-jaw lathe chuck Ø 80 mm, single clamping	3440287
Four-jaw lathe chuck Ø 80 mm, individual clamping	3440286
Four-jaw lathe chuck Ø 80 mm, centre clamping	3442808
> Information about lathe chucks from page 180	

Accessories	Article no.
Follow rest passageway max. Ø 45 mm	3440210
Steady rest passageway max. Ø 40 mm	3440211
Lathe tool set 8 mm, 5-part	3441662
Lathe tool set 8 mm, 11-part	3441601
Information on „Lathe tool set HM 8 mm“ on page 185	
Travelling centre MT 1	3440700
Collet chuck ER 16, Ø 22 mm, cylindrical	3440281
Collet kit ER 16, 1 - 10 mm, 12-part	3440282
> More accessories for lathes from page 184	

*Important information on „General notes on operating our machines“ on page 249

**The lathe (frequency converter) complies with the DIN EN 55011 standard: class C1 - Note for operation with frequency converter on page 249

Compatibility overview Accessories for lathes

Turning accessories		Article no.	TU 1503V	TU 2004V	TU 2304/V	TU 2406/V	TU 2506/V	TU 2807/V	TU 3008/G/V	TH 3309/D/V	TH 3610/D	TM 4010/D	TH 42	TH 4210V	TH 46	TH 4615V	TH 56	TH 5620V	TZ 4/TZ4V	TX 5216	TX 6222	TH 66	TH 80		
SWH	SWH AA	3384311	●																						
	SWH 1 - A	3384301		●	●	●	●	●	●																
	SWH 3 - E	3384303								●	●	○													
	SWH 5 - B	3384305											●	●	●	●				●					
	SWH 7 - C	3384307																●	●		●	●			
	SWH 9 - D	3384309																					●	●	
Lathe tool	HM 8 mm	3441662	●	●	●																				
	HM 10 mm	3441664			●	●	●	●	●																
	HM 12 mm	3441666			●	●	●	●	●																
	HM 12 mm	3441212			●	●	●	●	●																
	HM 16 mm	3441668								●	●	●													
	HM 16 mm	3441216								●	●	●													
	HM 16 mm	3441610								●	●	●													
	HM 20 mm	3441670											●	●	●	●	●	●	●	●	●				
	HM 20 mm	3441617											●	●	●	●	●	●	●	●	●				
	HM 25 mm	3441672																				●	●	●	
	HM 25 mm	3441623																				●	●	●	
	HM 32 mm	3441674																					●	●	
Single lathe tool 12 mm	SSSC L1212J09	3441225			●	●	●	●	●																
	SCLC L1212J09	3441226			●	●	●	●	●																
Lathe tool	HM 8 mm	3441601	●	●	●																				
	HM 10 mm	3441602			●	●	●	●	●																
	HM 12 mm	3441603			●	●	●	●	●																
	HM 16 mm	3441604								●	●	●													
Inside lathe tool set	10 mm	3441640			●	●	●	●	●																
	12 mm	3441641			●	●	●	●	●	●	●	●													
	Set	3441650								●	●	●	●	●	●	●	●	●	●	●	●	●	●	●	
Centring drill bit set	3203010			●	●	●	●	●	●	●	●	●	●	●	●	●	●	●	●	●	●	●	●	●	
Anti-vibration element	SE 1	3381012			●	●	●	●	●																
	SE 2	3381016			●	●	●	●	●	●	●	●													
	SE 3	3381018								●	●	●	●	●	●	●	●	●	●	●	●	●	●	●	
Levelling platen	SE 55	3352981	●	●	●	●	●	●	●																
	SE 85	3352982								●	●	●	●	●	●	●	●	●	●	●	●	●	●	●	
Clamping block	Set 16-05	3440653							●	●	●	●													
	Set 20-05	3440654										●	●	●	●	●	●	●	●	●	●	●	●	●	
	Set 25-05	3440655																					●	●	
Twist drill HSS	MT 2	3051002		●	●	●	●	●																	
	MT 3	3051003							●	●	●	●	○	○	○	○	○	○	○	○	○	○	○	○	
Clamping disc	Ø 170 mm	3440295	●																						
	Ø 220 mm	3440552			●																				
	Ø 240 mm	3441352					●																		
	Ø 265 mm	3441452						●																	
	Ø 300 mm No. 4	3442976							●	●															
	Ø 320 mm A2-5	3442979																		●					
	Ø 330 mm No. 5	3442978								●	●														
	Ø 350 mm No. 6	3442980										●	●	●											
Ø 450 mm No. 8	3442982														●	●	●		●	●	●	●	●		
Chuck flange	Ø 100 mm cyl.	3440312	●																						
	Ø 125 mm cyl.	3440313		●																					
	Ø 125 mm cyl.	3440511			●																				
	Ø 125 mm short	3441312				●		●																	
	Ø 160 mm short	3441413						●																	
BISON check flange	Ø 160 mm	3450245							●											●					

● Recommended ○ Recommended - restrictions apply

Turning accessories	Article no.	TU 1503V	TU 2004V	TU 2304/V	TU 2406/V	TU 2506/V	TU 2807/V	TU 3008/G/V	TH 3309/D/V	TH 3610/D	TM 4010/D	TH 42	TH 4210V	TH 46	TH 4615V	TH 56	TH 5620V	TZ 4/TZ4V	TX 5216	TX 6222	TH 66	TH 80	
Chuck flange	Ø 160 mm No. 4	3441512							●														
	Ø 200 mm No. 4	3441513							●														
	Ø 200 mm No. 5	3441514								●	●												
	Ø 200 mm No. 6	3444012										●	●	●									
	Ø 250 mm No. 6	3444013										●	●										
	Ø 315 mm No. 8	3444041													●	●	●		●	●	●	●	●
Collet chuck	ER16	3440281	●																				
	ER25	3440305		●	●																		
	ER25	3440505				●																	
	ER32	3440506				●																	
	ER25	3441305					●	●															
	ER32	3441306					●	●															
BISON collet chuck	16C	3450246																●					
Collet chuck	5C - No. 4	3441554						●	●														
	5C - No. 5	3441555								●	●												
	5C - No. 6	3441556										●	●	●									
	5C - No. 8	3441558													●	●	●		●	●	●	●	●
Travelling centre	MT 2	3440702	●	●	●	●	●																
	MT 3	3440703						●	●	●	●												
	MT 4	3440704										●	●	●	●								
	MT 5	3440705														●	●		●	●	●	●	●
Travelling centre with replaceable tips	MT 2	3440732	●	●	●	●	●																
	MT 3	3440733						●	●	●	●								●	●	●	●	●
	MT 4	3440734										●	●	●	●								
BISON Travelling centre	MT 2	3451002	●	●	●	●	●																
	MT 3	3451003					●	●	●	●								●					
	MT 4	3451004									●	●	●	●									
	MT 5	3451005													●	●		●	●	●	●	●	●
Collet kit	5C	3441509					●	●	●	●	●	●	●	●	●	●	●						
Collet kit	ER 16	3440282	●																				
	ER 25	3441109		●	●	●	●	●															
	ER 32	3441122		●	●	●	●	●															
Collet chuck device	5C	3441506						●															
	5C	3441507										●											
Position stop		3441522							●														
		3441523								●													
		3444022											●	●									
		3444023														●	●						
Fixed steady		3440211	●																				
		3440231		●																			
		3440361			●																		
		3440515				●																	
		3441315					●																
		3441415						●															
Travelling steady		3440210	●																				
		3440230		●																			
		3440360			●																		
		3441310				●	●																
		3441410						●															
	3441460							●															
Universal coolant unit	230 V	3352002	●	●	●	●	●	●	●	●													

This equipment table covers all recommended equipment options. Depending on the individual case, use of accessories can be meaningful beyond this.

Lathe chuck

OPTIMUM

Three-jaw lathe chuck

OPTIMUM Three-jaw lathe chuck centre clamping

► Cast lathe chuck

- › Cylindrical centring mount as per DIN 6350
- › Concentricity better than 0.05 mm
- › Chuck flange required
- › **Scope of delivery:** Chuck key, hard single-part outside clamping jaws

Ø 80 mm	3440287
Block jaw set, soft 1-part - 3 pcs.	3442902
Ø 100 mm	3442710
Block jaw set, soft 1-part - 3 pcs.	3442904
Ø 125 mm	3442712
Block jaw set, soft 1-part - 3 pcs.	3442906
Ø 160 mm	3442716
Block jaw set, soft 1-part - 3 pcs.	3442907



„Chuck flange“ on page 192

OPTIMUM

Three-jaw lathe chuck Camlock

OPTIMUM Three-jaw lathe chuck Camlock centre clamping

► Cast lathe chuck

- › Camlock direct mount DIN 55029
- › **Scope of delivery:** Chuck key, hard single-part outside clamping jaws

Ø 160 mm Camlock DIN ISO 702-2 No. 4	3442761
Block jaw set, soft 1-part - 3 pcs.	3442907
Ø 200 mm Camlock DIN ISO 702-2 No. 4	3442762
Block jaw set, soft 1-part - 3 pcs.	3442910
Ø 200 mm Camlock DIN ISO 702-2 No. 5	3442764
Block jaw set, soft 1-part - 3 pcs.	3442910
Ø 200 mm Camlock DIN ISO 702-2 No. 6	3442763
Block jaw set, soft 1-part - 3 pcs.	3442910
Ø 250 mm Camlock DIN ISO 702-2 No. 6	3442765
Block jaw set, soft 1-part - 3 pcs.	3442912
Ø 315 mm Camlock DIN ISO 702-2 No. 8	3442768
Block jaw set, soft 1-part - 3 pcs.	3442916



OPTIMUM

Four-jaw lathe chuck

OPTIMUM Four-jaw lathe chuck centre clamping

► Cast lathe chuck

- › Cylindrical centring mount as per DIN 6350
- › Concentricity better than 0.05 mm
- › Chuck flange required
- › **Scope of delivery:** Chuck key, hard single-part outside clamping jaws

Ø 80 mm	3442808
Block jaw set, soft 1-part - 4 pcs.	3442920
Ø 100 mm	3442810
Block jaw set, soft 1-part - 4 pcs.	3442922
Ø 125 mm	3442812
Block jaw set, soft 1-part - 4 pcs.	3442924
Ø 160 mm	3442816
Block jaw set, soft 1-part - 4 pcs.	3442926



OPTIMUM Four-jaw lathe chuck individual clamping

- › **Scope of delivery:** Chuck key, set of hard reversible jaws

Ø 80 mm	3440286
Ø 100 mm	3442872
Ø 125 mm	3442874



OPTIMUM Data on the Lathe chucks, see page 183
„Chuck flange“ on page 192

OPTIMUM

Four-jaw lathe chuck Camlock

OPTIMUM Four-jaw lathe chuck Camlock centre clamping

► Cast lathe chuck

- › Camlock direct mount DIN 55029
- › **Scope of delivery:** Chuck key, hard single-part outside clamping jaws

Ø 160 mm Camlock DIN ISO 702-2 No. 4	3442840
Block jaw set, soft 1-part - 4 pcs.	3442926
Ø 200 mm Camlock DIN ISO 702-2 No. 4	3442843
Block jaw set, soft 1-part - 4 pcs.	3442927
Ø 200 mm Camlock DIN ISO 702-2 No. 5	3442845
Block jaw set, soft 1-part - 4 pcs.	3442927
Ø 200 mm Camlock DIN ISO 702-2 No. 6	3442846
Block jaw set, soft 1-part - 4 pcs.	3442928
Ø 250 mm Camlock DIN ISO 702-2 No. 6	3442852
Block jaw set, soft 1-part - 4 pcs.	3442935
Ø 315 mm Camlock DIN ISO 702-2 No. 8	3442856
Block jaw set, soft 1-part - 4 pcs.	3442938



OPTIMUM Four-jaw lathe chuck Camlock individual clamping

- › **Scope of delivery:** Chuck key, set of hard reversible jaws

Ø 200 mm Camlock DIN ISO 702-2 No. 4	3442879
Ø 200 mm Camlock DIN ISO 702-2 No. 5	3442880
Ø 250 mm Camlock DIN ISO 702-2 No. 6	3442884
Ø 315 mm Camlock DIN ISO 702-2 No. 8	3442888
Ø 400 mm Camlock DIN ISO 702-2 No. 8	3442890



Three-jaw lathe chuck

BISON Three-jaw lathe chuck centre clamping

► **Lathe chuck body made of premium cast material**

- › All work surfaces induction tempered and polished to ensure a high level of clamping and repetition accuracy
- › Uniform clamping forces
- › High concentricity (better than DIN 6386)
- › **Scope of delivery:** Chuck key, hard single-part outside clamping jaws

Ø 125 mm DIN 6350	3450230
Block jaw set, soft	3450410
Ø 160 mm DIN 6350	3450232
Block jaw set, soft	3450412



BISON Three-jaw lathe chuck centre clamping

► **Lathe chuck body made of premium steel**

- › **Scope of delivery:** Chuck key, hard single-part outside clamping jaws

Ø 250 mm Camlock DIN ISO 702-2 No. 6	3450530
Block jaw set, soft	3450426



Four-jaw lathe chuck

BISON Four-jaw lathe chuck centre clamping

► **Lathe chuck body made of premium cast material**

- › All work surfaces induction tempered and polished
- › Uniform clamping forces
- › High concentricity (better than DIN 6386)
- › **Scope of delivery:** Chuck key, hard single-part outside clamping jaws

Ø 125 mm DIN 6350	3450234
Block jaw set, soft	3450420
Ø 160 mm DIN 6350	3450236
Block jaw set, soft	3450422

Chuck flange

Ø 125 mm for three- and four-jaw lathe chucks Ø 125 mm	3450240
Ø 160 mm for three- and four-jaw lathe chucks Ø 160 mm	3450241
Ø 200 mm for three- and four-jaw lathe chucks Ø 200 mm	3450212
Ø 250 mm for three- and four-jaw lathe chucks Ø 250 mm	3450218

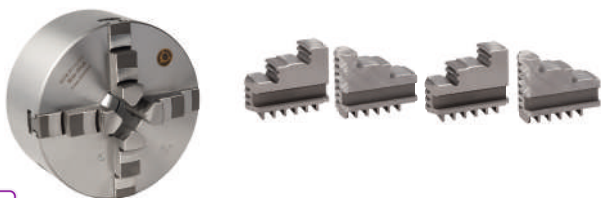

„Technical data four-jaw lathe chuck“ on page 183
„Chuck flange“ on page 192



Three-jaw lathe chuck Camlock

BISON Three-jaw lathe chuck Camlock centre clamping

► **Lathe chuck body made of premium cast material**

- › All work surfaces induction tempered and polished
- › Camlock direct mount DIN 55029
- › High concentricity (better than DIN 6386)
- › Incl. chuck key, hard single-part outside clamping jaws

Ø 160 mm Camlock DIN ISO 702-2 No. 4	3450305
Block jaw set, soft	3450412
Ø 200 mm Camlock DIN ISO 702-2 No. 4	3450310
Block jaw set, soft	3450414
Ø 200 mm Camlock DIN ISO 702-2 No. 5	3450315
Block jaw set, soft	3450414
Ø 200 mm Camlock DIN ISO 702-2 No. 6	3450320
Block jaw set, soft	3450414
Ø 200 mm DIN 6350 A2-5	3450210
Block jaw set, soft	3450414
Ø 250 mm Camlock DIN ISO 702-2 No. 5	3450325
Block jaw set, soft	3450416
Ø 250 mm Camlock DIN ISO 702-2 No. 6	3450330
Block jaw set, soft	3450416
Ø 250 mm Camlock DIN ISO 702-2 No. 8	3450331
Block jaw set, soft	3450416
Ø 315 mm Camlock DIN ISO 702-2 No. 8	3450335
Block jaw set, soft	3450418



Four-jaw lathe chuck Camlock

BISON Four-jaw lathe chuck Camlock centre clamping

► **Lathe chuck body made of premium cast material**

- › Incl. chuck key, hard single-part outside clamping jaws

Ø 160 mm Camlock DIN ISO 702-2 No. 4	3450355
Block jaw set, soft	3450422
Ø 200 mm Camlock DIN ISO 702-2 No. 4	3450360
Block jaw set, soft	3450424
Ø 200 mm Camlock DIN ISO 702-2 No. 5	3450365
Block jaw set, soft	3450424
Ø 200 mm Camlock DIN ISO 702-2 No. 6	3450370
Block jaw set, soft	3450424
Ø 250 mm DIN 6350 for A2-5	3450216
Block jaw set, soft	3450426
Ø 250 mm Camlock DIN ISO 702-2 No. 5	3450375
Block jaw set, soft	3450426
Ø 250 mm Camlock DIN ISO 702-2 No. 6	3450380
Block jaw set, soft	3450426
Ø 250 mm Camlock DIN ISO 702-2 No. 8	3450381
Block jaw set, soft	3450426
Ø 315 mm Camlock DIN ISO 702-2 No. 8	3450385
Block jaw set, soft	3450428
Ø 400 mm Camlock DIN ISO 702-2 No. 8	3450390
Block jaw set, soft	3450430

BISON Four-jaw lathe chuck Camlock centre clamping

► **Lathe chuck body made of premium steel**

- › Incl. chuck key, hard single-part outside clamping jaws

Ø 250 mm Camlock DIN ISO 702-2 No. 6	3450580
Block jaw set, soft	3450426
Ø 250 mm DIN 6350 for A2-5	3450217
Block jaw set, soft	3450426



Preface

Drilling

Milling

Turning accessories

Saws

Grinding

Polishing

Lamps

Measuring

Technical data for three-jaw lathe chuck

OPTIMUM

Three-jaw lathe chuck

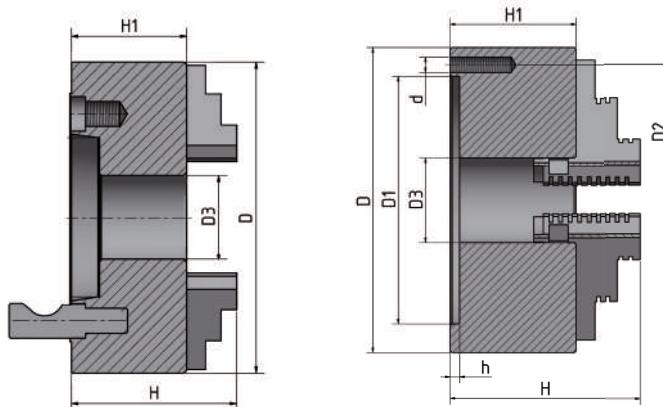

Chuck	Art. no.	D	D1	D2	D3	d	H	H1	h	Rotational speed (rpm)
Ø 80 mm	3440287	80	55	66	16	M6	66	50	3.5	4 000
Ø 100 mm	3442710	100	72	84	22	8M	74.5	55	3.5	4 200
Ø 125 mm	3442712	125	95	108	30	M8	84	58	4	3 800
Ø 160 mm	3442716	160	130	142	40	M8	95	65	5	3 000

Chuck	Camlock	Art. no.	D	D3	H	H1	Indexing circle	Rotational speed (rpm)
Ø 160 mm	No.4	3442761	160	40	101	71	82.6	3 000
Ø 200 mm	No.4	3442762	200	50	124	86	82.6	3 000
Ø 200 mm	No.5	3442764	200	50	124	86	104.8	3 000
Ø 200 mm	No.6	3442763	200	50	128	86	133.4	3 000
Ø 250 mm	No.6	3442765	250	70	140	98	133.4	2 400
Ø 315 mm	No.8	3442768	315	105	180	103.5	171.4	1 800

BISON

Three-jaw lathe chuck

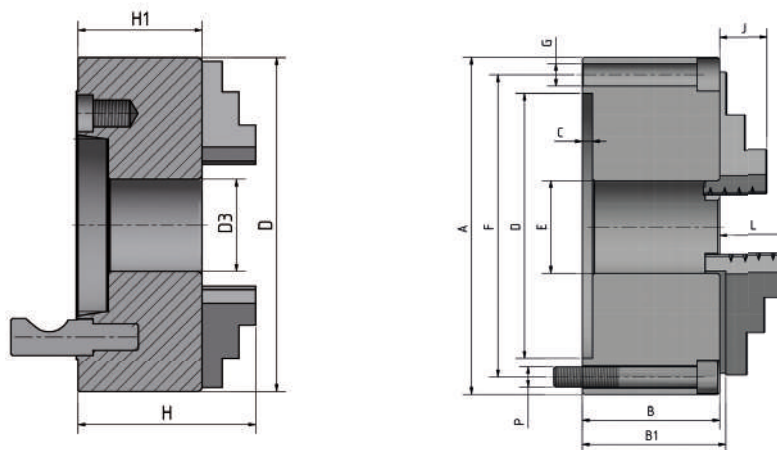

Chuck	Camlock	Art. no.	D	D3	H1	H	Indexing circle	Rotational speed (rpm)
Ø 160 mm	No.4	3450305	160	42	81.5	124.5	82.6	3 600
Ø 200 mm	No.4	3450310	200	56	107	136	82.6	3 000
Ø 200 mm	No.5	3450315	200	56	107	136	104.8	3 000
Ø 200 mm	No.6	3450320	200	55	91	136	133.4	3 000
Ø 250 mm	No.5	3450325	250	76	103.5	156.5	104.8	2 500
Ø 250 mm	No.6	3450330	250	76	103.5	156.5	133.4	2 500
Ø 250 mm	No.8	3450331	250	76	103.5	156.5	171.4	2 500
Ø 315 mm	No.8	3450335	315	103	117.7	174.7	171.4	2 000

Chuck	Art. no.	B	B1	C	D	E	F	G	J	L	kg	Rotational speed (rpm)
Ø 125 mm	3450230	56	60.8	4	95	32	108	3 x M8	20	40	5	4 000
Ø 160 mm	3450232	64.5	69.3	4	125	42	140	3 x M10	32	43	10	3 600

Technical data four-jaw lathe chuck

OPTIMUM

Four-jaw lathe chuck

Chuck	Art. no.	D	D1	D2	D3	d	H	H1	h	Rotational speed (rpm)
Centre clamping										
Ø 80 mm	3442808	80	55	66	16	M6	66	50	3.5	4 300
Ø 100 mm	3442810	100	72	84	22	8M	74.5	55	3.5	3 400
Ø 125 mm	3442812	125	95	108	30	M8	84	58	4	2 750
Ø 160 mm	3442816	160	130	142	40	M8	95	65	5	2 150
Individual clamping										
Ø 80 mm	3440286	80	55	66	22	M6	56	42	3.5	4 800
Ø 100 mm	3442872	100	72	84	25	M8	73	54	3.5	3 500
Ø 125 mm	3442874	125	95	108	30	M8	78	58	4.5	3 000

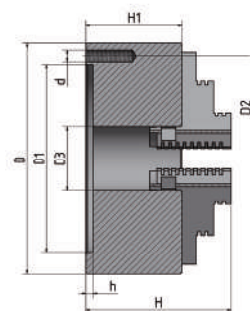

Chuck	Camlock	Art. no.	D	D3	H	H1	Indexing circle	Rotational speed (rpm)
Camlock centre clamping								
Ø 160 mm	No.4	3442840	160	40	95	70	82.6	2 150
Ø 200 mm	No.4	3442843	200	55	109	86	82.6	3 000
Ø 200 mm	No.5	3442845	200	55	109	86	104.8	3 000
Ø 200 mm	No.6	3442846	200	65	109	86	133.4	3 000
Ø 250 mm	No.6	3442852	250	70	120	95	133.4	2 400
Ø 315 mm	No.8	3442856	315	100	142.5	106	171.4	1 800
Camlock individual clamping								
Ø 200 mm	No.4	3442879	200	55	120	91	82.6	2 100
Ø 200 mm	No.5	3442880	200	55	120	91	104.8	2 100
Ø 250 mm	No.6	3442884	250	65	117.5	82	133.4	1 600
Ø 315 mm	No.8	3442888	315	95	134	90	171.4	1 200
Ø 400 mm	No.8	3442890	400	125	143	95	171.4	1 000

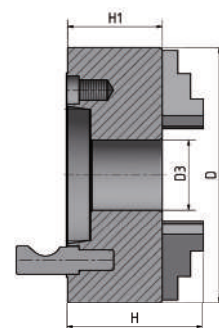
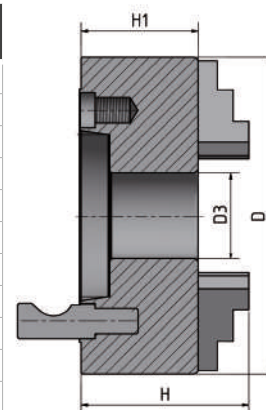

Four-jaw lathe chuck

Chuck	Camlock	Art. no.	D	D3	H1	H	Indexing circle	Rotational speed (rpm)
Ø 160 mm	No.4	3450355	160	42	81.5	124.5	82.6	3 600
Ø 200 mm	No.4	3450360	200	55	91	136	82.6	3 000
Ø 200 mm	No.5	3450365	200	55	91	136	104.8	3 000
Ø 200 mm	No.6	3450370	200	55	91	136	133.4	3 000
Ø 250 mm	No.5	3450375	250	76	103.5	156.5	104.8	2 500
Ø 250 mm	No.6	3450380	250	76	103.5	156.5	133.4	2 500
Ø 250 mm	No.8	3450381	250	76	103.5	156.5	171.4	2 500
Ø 315 mm	No.8	3450385	315	103	117.7	174.7	171.4	2 000
Ø 400 mm	No.8	3450390	400	136	128.5	207.5	171.4	1 600

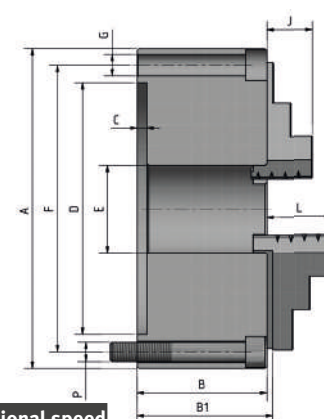

Chuck	Art. no.	B	B1	C	D H7	E	F	G	J	L	kg	Rotational speed (rpm)
Ø 125 mm	3450234	56	60.8	4	95	32	108	3 x M8	20	40	5	4 000
Ø 160 mm	3450236	64.5	69.3	4	125	42	140	3 x M10	32	43	10	3 600
Ø 250 mm	3450216	75	79.8	4	160	55	176	6 x M10	29	45	17.5	2 500
NEW Ø 250 mm	3450217	75	79.8	4	160	55	176	6 x M10	29	45	17.5	3 500

Quick change tool holder

Quick change tool holder

- › Repetition accuracy 0.01 mm · angle scale on tool holder head
- › 40 different angle settings · Height adjustment via star knob
- › Tool holder head and tool holder with profile ground gears
- › Play-free and repetition-accurate clamping of the change holder
- › For self-assembly!

Quick change tool holder set SWH AA

3384311

- › Tool holder head AA
- › 3 pcs. tool holder 12 x 50 type D for square chisels
- › 1 pc. tool holder 12 x 50 type H for round chisels

Spare tool holder 12 x 50 Type D for square chisels 3384312

Spare tool holder 12 x 50 Type H for round chisels 3384320

Quick change tool holder set SWH 1-A

3384301

- › Tool holder head A
- › 3 pcs. tool holder 20 x 90 type D for square chisels
- › 1 pc. tool holder 20 x 85 type H for round chisels

Spare tool holder 20 x 90 type D for square chisels 3384302

Spare tool holder 20 x 85 type H for round chisels 3384321

Quick change tool holder set SWH 3-E

3384303

- › Tool holder head E
- › 3 pcs. tool holder 20 x 100 type D for square chisels
- › 1 pc. tool holder 30 x 100 type H for round chisels

Spare tool holder 20 x 100 type D for square chisels 3384304

Spare tool holder 30 x 100 type H for round chisels 3384322

Quick change tool holder set SWH 5-B

3384305

- › Tool holder head B
- › 3 pcs. tool holder 25 x 120 type D for square chisels
- › 1 pc. tool holder 32 x 130 type H for round chisels

Spare tool holder 25 x 120 type D for square chisels 3384306

Spare tool holder 32 x 130 type H for round chisels 3384324

Quick change tool holder set SWH 7-C

3384307

- › Tool holder head C
- › 3 pcs. tool holder 32 x 150 type D for square chisels
- › 1 pc. tool holder 40 x 160 type H for round chisels

Spare tool holder 32 x 150 type D for square chisels 3384308

Spare tool holder 40 x 160 type H for round chisels 3384326

Quick change tool holder set SWH 9-D

3384309

- › Tool holder head D
- › 3 pcs. tool holder 40 x 180 type D for square chisels
- › 1 pc. tool holder 63 x 180 type H for round chisels

Spare tool holder 40 x 180 type D for square chisels 3384332

Spare tool holder 63 x 180 type H for round chisels 3384333

Factory assembly and adjustment SWH

9000400

- › Only with orders for new machines



Tool holder head



Tool holder type D for square chisels

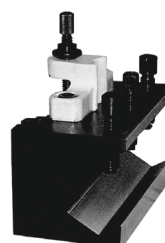

Tool holder type H for round chisels

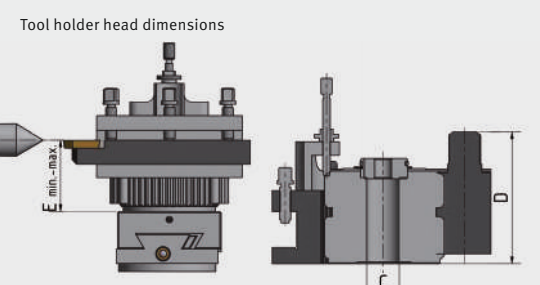
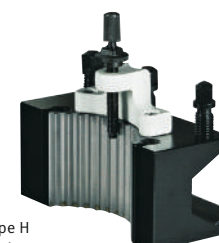

Tool holder head dimensions

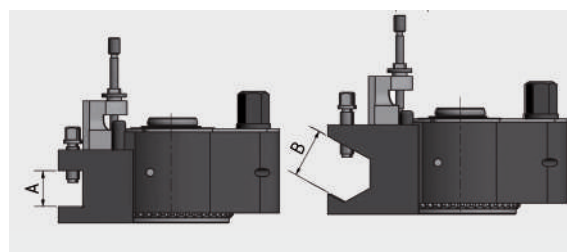

Tool holder head dimensions			SWH AA	SWH 1-A	SWH 3-E	SWH 5-B	SWH 7-C	SWH 9-D
Turning diameter		mm	120 - 220	150 - 300	200 - 400	300 - 500	400 - 700	600 - 800
Drive output lathe max.		kW	1	2	4.5	7	13	20
Support width square chisel max.	A	mm	12	20	20	25	32	40
Diameter round chisel max.	B	mm	Ø 12	Ø 20	Ø 20	Ø 25	Ø 32	Ø 40
Normal bore	C	mm	Ø 13	Ø 20	Ø 20	Ø 32	Ø 40	Ø 40
Height of base body/overall	D	mm	37	56	68	79	110	122
Height top carriage to lathe centre	E	mm	18 - 26	28.5 - 39.5	28.5 - 39.5	37 - 57	47 - 87	60 - 95

Lathe tool set

Lathe tool set HM 8 mm

Lathe tool set HM 8 mm 3441662

- > 5-part
- > With HM turning plates
- > TiN coated
- > Aluminium box

	ISO			h1
1	SWGC	L0808	D05	8 mm
2	SSDC	N0808	D06	8 mm
3	SWGC	R0808	D05	8 mm
4	STGC	R0808	D09	8 mm
5	SDJC	R0808	D07	8 mm



HM replacement turning plates (5 pcs. each)

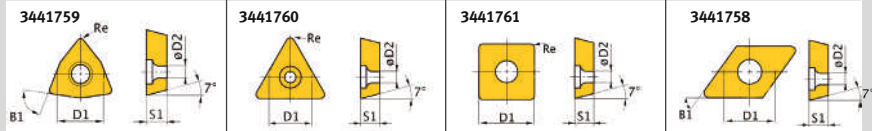

No.	Art. no.	ISO	D1	D2	B1	S1	right
1/3	3441759	WCMT050308	7.94	3.2	80°	3.18	0.8
2	3441761	SCMT060204	6.35	2.8	90°	2.38	0.4
4	3441760	TCMT090204	5.56	2.5	60°	2.38	0.4
5	3441758	DCMT070204	6.35	2.8	55°	2.38	0.4

Lathe tool set HM 10 mm

Lathe tool set HM 10 mm 3441664

- > 5-part
- > With HM turning plates
- > TiN coated
- > Aluminium box

	ISO			h1
1	SWGC	L1010	E05	10 mm
2	SSDC	N1010	E06	10 mm
3	SWGC	R1010	E05	10 mm
4	STGC	R1010	E09	10 mm
5	SDJC	R1010	E07	10 mm



HM replacement turning plates (5 pcs. each)

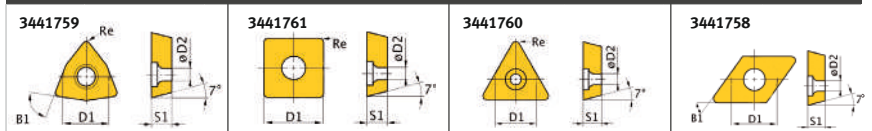

No.	Art. no.	ISO	D1	D2	B1	S1	right
1/3	3441759	WCMT050308	7.94	3.2	80°	3.18	0.8
2	3441761	SCMT060204	6.35	2.8	90°	2.38	0.4
4	3441760	TCMT090204	5.56	2.5	60°	2.38	0.4
5	3441758	DCMT070204	6.35	2.8	55°	2.38	0.4

Lathe tool set HM 12 mm

Lathe tool set HM 12 mm 3441666

- > 5-part
- > With HM turning plates
- > TiN coated
- > Aluminium box

	ISO			h1
1	SWGC	L1212	H 05	12 mm
2	SSDC	N1212	H 09	12 mm
3	SWGC	R1212	H 05	12 mm
4	STGC	R1212	H 11	12 mm
5	SDJC	R1212	H 07	12 mm



HM replacement turning plates (5 pcs. each)

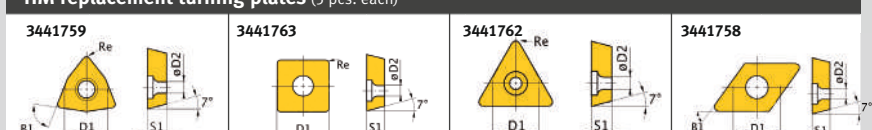

No.	Art. no.	ISO	D1	D2	B1	S1	right
1/3	3441759	WCMT050308	7.94	3.2	80°	3.18	0.8
2	3441763	SCMT09T304	6.35	2.8	90°	2.38	0.4
4	3441762	TCMT110204	6.35	2.8	60°	2.38	0.4
5	3441758	DCMT070204	6.35	2.8	55°	2.38	0.4

Lathe tool set

Lathe tool set HM 12 mm

Lathe tool set HM 12 mm	3441212
› 5-part	
› With HM turning plates	
› TiN coated	

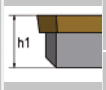
	ISO		Single lathe tool
			Art.no.
1	SSSC R1212 J09	12 mm	3441220
2	SCLC R1212 J09	12 mm	3441221
3	SDNC N1212 J11	12 mm	3441222
4	SDJC R1212 J11	12 mm	3441223
5	SDJC L1212 J11	12 mm	3441224

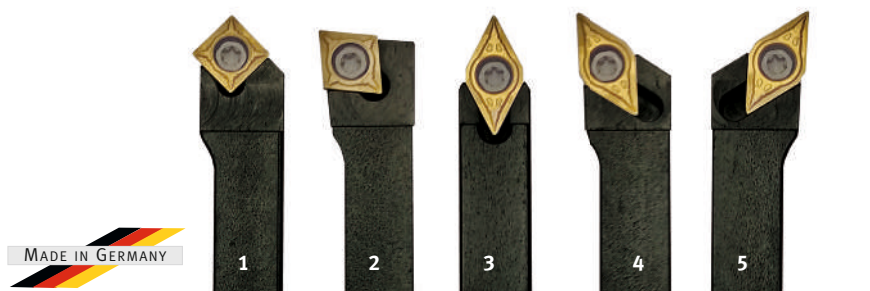

HM replacement turning plates (5 pcs. each)

No.	Art. no.	ISO	D1	D2	B1	S1	right
1	3441280	SCMT09T304	9.525	4.4	90°	3.97	0.4
2	3441282	CCMT09T304	9.525	4.4	80°	3.97	0.4
3-5	3441281	DCMT11T304	9.525	4.4	55°	3.97	0.4

NEW

Lathe tool 12 mm	MADE IN GERMANY	Article no.
SSSC L1212J09		3441225
HM replacement turning plates (5 pcs. each)		3441280
SCMT09T304	9.525 4.4 90° 3.97 0.4	

NEW

Lathe tool 12 mm	MADE IN GERMANY	Article no.
SCLC L1212J09		3441226
HM replacement turning plates (5 pcs. each)		3441282
CCMT09T304	9.525 4.4 80° 3.97 0.4	

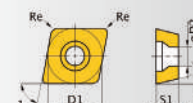
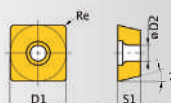

Lathe tool set HM 16 mm

Lathe tool set HM 16 mm	3441216
› 5-part	
› With HM turning plates	
› TiN coated	

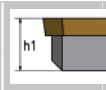
	ISO		Single lathe tool
			Art.no.
1	SSSC R1616 J09	16 mm	3441230
2	SCLC R1616 J09	16 mm	3441231
3	SDNC N1616 J11	16 mm	3441232
4	SDJC R1616 J11	16 mm	3441233
5	SDJC L1616 J11	16 mm	3441234



HM replacement turning plates (5 pcs. each)

No.	Art. no.	ISO	D1	D2	B1	S1	right
1	3441280	SCMT09T304	9.525	4.4	90°	3.97	0.4
2	3441282	CCMT09T304	9.525	4.4	80°	3.97	0.4
3-5	3441281	DCMT11T304	9.525	4.4	55°	3.97	0.4

Lathe tool set HM 16 mm

Lathe tool set HM 16 mm	3441668
› 5-part	
› With HM turning plates	
› TiN coated	
› Aluminium box	

	ISO				h1
1	PWLN	R1616	H06		16 mm
2	PWLN	L1616	H06		16 mm
3	PSDNN	1616	H09		16 mm
4	CKJN	R1616	H16		16 mm
5	MDJN	R1616	H11		16 mm

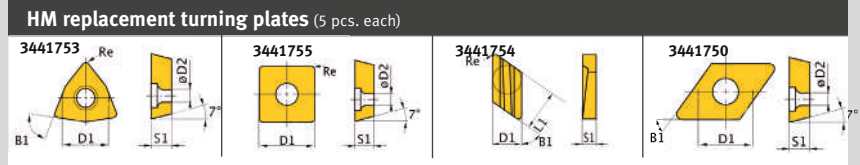
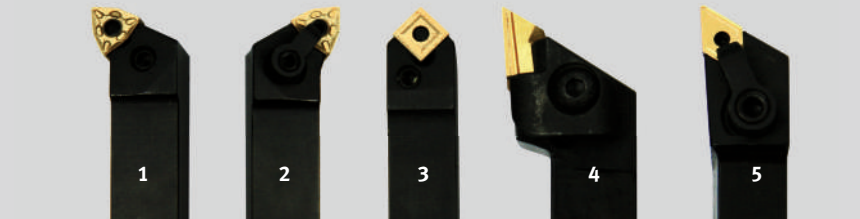

No.	Art. no.	ISO	D1	D2	B1	S1	right	L1
1/2	3441753	WNMG060408	9.252	3.81	80°	4.76	0.8	
3	3441755	SNMG090304	9.252	3.81	90°	3.18	0.4	
4	3441754	KNUX160405R	9.252		55°	4.76	0.5	16.15
5	3441750	DNMG110408	9.525	3.81	55°	4.76	0.8	

Lathe tool set HM 16 mm

Lathe tool set HM 16 mm	3441610
› 5-part	
› With HM turning plates	
› TiN coated	
› Aluminium box	

	ISO				h1
1	MVJNR	1616	H16		16 mm
2	MVVNN	1616	H16		16 mm
3	PRANN	1616	H10		16 mm
4	PRGNR	1616	H10		16 mm
5	SER	1616	H16		16 mm

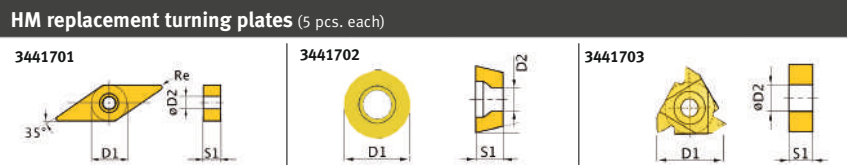
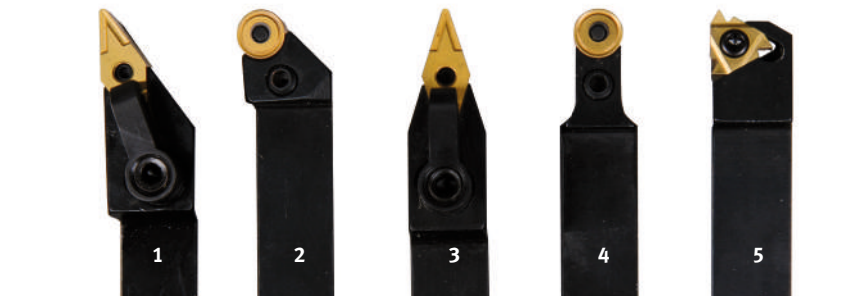

No.	Art. no.	ISO	D1	D2	B1	S1	right
1/2	3441701	VNMG160408	9.525	3.81	35°	4.76	0.8
3/4	3441702	RNMM1003MO	10	3.6	-	3.97	
5	3441703	16ER AG60	16	3.95	60°	3.65	

Lathe tool set HM 16 mm

Lathe tool set HM 16 mm	3441670
› 5-part	
› With HM turning plates	
› TiN coated	
› Aluminium box	

	ISO				h1
1	PWLN	R2020	08 grain		20 mm
2	PWLN	L2020	08 grain		20 mm
3	PSDN	N2020	12 grain		20 mm
4	CKJN	R2020	16 grain		20 mm
5	MDJN	R2020	11 grain		20 mm

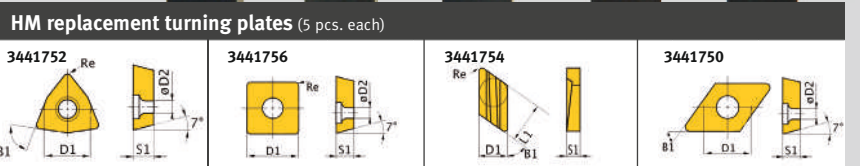
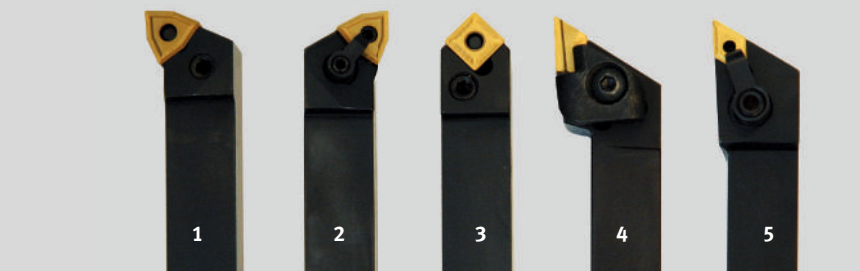

No.	Art. no.	ISO	D1	D2	B1	S1	right	L1
1/2	3441752	WNMG080408	9.252	3.81	80°	4.76	0.8	
3	3441756	SNMG120408	12.7	5.16	90°	4.76	0.8	
4	3441754	KNUX160405R	9.252		55°	4.76	0.5	16.15
5	3441750	DNMG110408	9.525	3.81	55°	4.76	0.8	

Lathe tool set

Lathe tool set HM 20 mm

Lathe tool set HM 20 mm	3441617
› 5-part	
› With HM turning plates	
› TiN coated	
› Aluminium box	

	ISO				h1
1	SER	2020	16 grain	20 mm	
2	PRGNR	2020	10 grain	20 mm	
3	PRANN	2020	10 grain	20 mm	
4	MVVNN	2020	16 grain	20 mm	
5	MVJNR	2020	16 grain	20 mm	

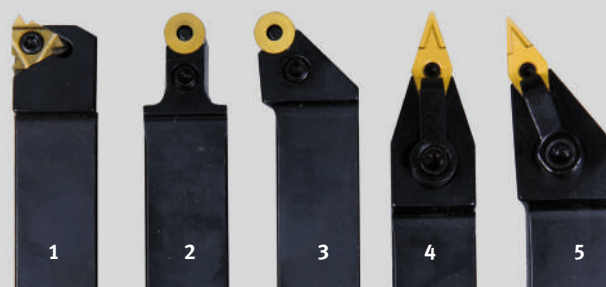

HM replacement turning plates (5 pcs. each)

No.	Art. no.	ISO	D1	D2	B1	S1	right
1	3441703	16ER AG60	16	3.95	60°	3.65	
2/3	3441702	RNMM1003MO	10	3.6	-	3.97	
4/5	3441701	VNMG160408	9 525	3.81	35°	4.76	0.8

Lathe tool set HM 25 mm

Lathe tool set HM 25 mm	3441623
› 5-part	
› With HM turning plates	
› TiN coated	
› Aluminium box	

	ISO				h1
1	MVVN	N2525	M16	25 mm	
2	SE	R2525	M16	25 mm	
3	PRGN	R2525	M12	25 mm	
4	PRAN	N2525	M16	25 mm	
5	MVJN	R2525	M16	25 mm	

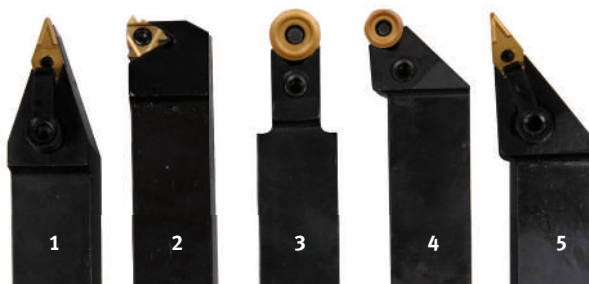

HM replacement turning plates (5 pcs. each)

No.	Art. no.	ISO	D1	D2	B1	S1	right
1/2	3441701	VNMG160408	9 525	3.81	35°	4.76	0.8
3	3441703	16ER AG60	16	3.95	60°	3.65	
4	3441705	RNMG1204MO	12	4.75	R	5.1	-
5	3441704	RNMG1605MO	16	5.4	R	6.3	-

Lathe tool set HM 25 mm

Lathe tool set HM 25 mm	3441672
› 5-part	
› With HM turning plates	
› TiN coated	
› Aluminium box	

	ISO				h1
1	PWLN	L2525	M08	25 mm	
2	PSDN	N2525	M15	25 mm	
3	PWLN	R2525	M08	25 mm	
4	CKJNR	R2525	M16	25 mm	
5	MDJN	R2525	M15	25 mm	

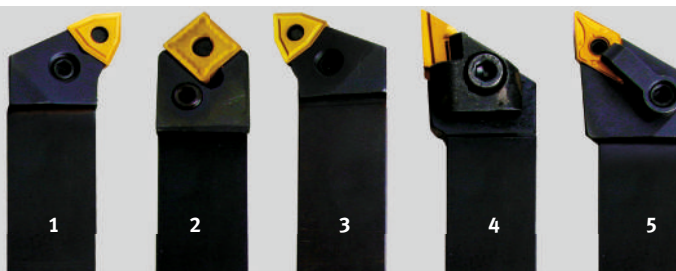

HM replacement turning plates (5 pcs. each)

No.	Art. no.	ISO	D1	D2	B1	S1	right	L1
1/2	3441752	WNMG080408	9.252	3.81	80°	4.76	0.8	
3	3441757	SNMG150608	15.875	6.35	90°	6.35	0.8	
4	3441754	KNUX160405R	9.252		55°	4.76	0.5	16.15
5	3441751	DNMG150408	12.7	5.16	55°	4.76	0.8	

Lathe tool set HM 32 mm

Lathe tool set HM 32 mm 3441674

- > 5-part
- > With HM turning plates
- > TiN coated
- > Aluminium box

No.	ISO	h1
1	PWLN L3232 P08	32 mm
2	PSDN N3232 P15	32 mm
3	PWLN R3232 P08	32 mm
4	CKJN R3232 P16	32 mm
5	MDJN R3232 P15	32 mm



HM replacement turning plates (5 pcs. each)

No.	Art. no.	ISO	D1	D2	B1	S1	right	L1
56/58	3441752	WNMG080408	9.252	3.81	80°	4.76	0.8	
57	3441757	SNMG150608	15.875	6.35	90°	6.35	0.8	
59	3441754	KNUX160405R	9.252		55°	4.76	0.5	16.15
60	3441751	DNMG150408	12.7	5.16	55°	4.76	0.8	

Inside lathe tool set 10 mm

Inside lathe tool set 10 mm 3441640

- > 3-part
- > With HM turning plates
- > TiN coated
- > Aluminium box

No.	ISO
1	S10K SCFCR 06
2	S10K SDQCR 07
3	S10K STFCR 11



HM replacement turning plates (5 pcs. each)

No.	Art. no.	ISO	l	s	R	d	d1	
61	3441164	CCMT060204	C/80°	6.35	2.60	0.40	6.35	2.70
62	3441163	TCMT110204	T/60°	10.84	2.53	0.40	9.1	2.70
63	3441166	DCMT070204	D/55°	7.30	2.53	0.40	6.35	2.70

Inside lathe tool set 12 mm

Inside lathe tool set 12 mm 3441641

- > 3-part
- > With HM turning plates
- > TiN coated
- > Aluminium box

No.	ISO
1	S12M SCFCR 06
2	S12M SDQCR 07
3	S12M STFCR 11

Inside thread turning tool set 8 - 20 mm

Inside thread turning tool set 3441650

- > 5-part (8/10/12/16/20 mm)
- > With HM turning plates
- > TiN coated
- > Aluminium box

No.	ISO	d
1	S10K SIR 0008 H08	8 mm
2	S10K SIR 0010 11 grain	10 mm
3	S10K SIR 0012 M11	12 mm
4	S10K SIR 0016 P16	16 mm
5	S10K SIR 0020 S16	20 mm



HM replacement turning plates (5 pcs. each)

No.	Art. no.	ISO	l	s	R	d	d1	
1	3441725	08IR A60	60° IR	8	2.22	4.76	2.5	M10
2/3	3441726	11IR A60	60° IR	11	3.22	6.35	3.0	M12
4/5	3441727	16IR A60	60° IR	16	3.65	9.5	3.95	M16

Accessories for lathes

Lathe tool set 8 / 10 / 12 / 16 mm

Lathe tool set HM 8 mm	3441601
11-part . With HM plates soldered on	
Lathe tool set HM 10 mm	3441602
11-part . With HM plates soldered on	
Lathe tool set HM 12 mm	3441603
11-part . With HM plates soldered on	
Lathe tool set HM 16 mm	3441604
11-part . With HM plates soldered on	

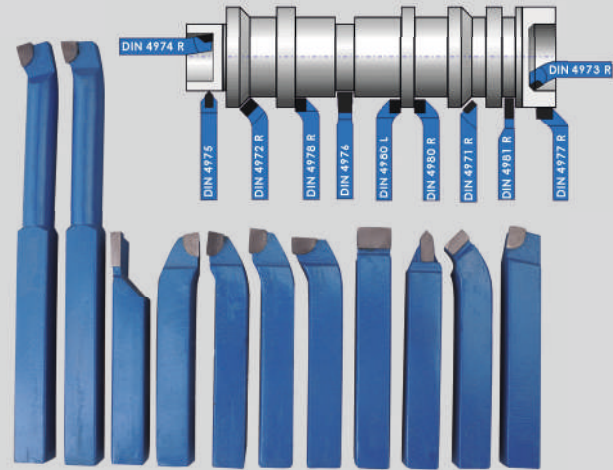

NEW

Pilot bit set	3203010
<ul style="list-style-type: none"> › As per DIN 333 shape A › 10-part: 0.75/1/1.5/1.6/2/2.5/3/3.15/4/5 mm › Right-hand cutting chisel edge 120° › Countersinking angle 60° › Top quality HSS for tensile strength up to approx. 750 N/mm² › Powerful shank, also well suited for predrilling and expansion drilling with a twist drill bit › Practical OPTIMUM plastic case 	



Vibration damping machine base

- › The machines and equipment can be installed without anchors and precisely levelled using the height adjustment system.
- › Effective impact and vibration damping improves the machine's capability

SE 1	3381012
SE 2	3381016
SE 3	3381018



Load	SE 1	SE 2	SE 3
Milling machines	340 kg	460 kg	1 600 kg
Sawing/gen. Machine	570 kg	1 460 kg	3 500 kg
Threading	M12	M16	M 20
Base Ø/Base height	120/32	160/35	185/39

NEW

Levelling platen/vibration damper	Article no.
<ul style="list-style-type: none"> › Effective vibration and structure-borne noise insulation and noise reduction › Fast and technically uncomplicated levelling › Eliminates floor unevenness up to 5° › Precision levelling by means of a regular threaded screw › Better distribution of impact-like axial forces due to the geometrically larger contact surface with the screw. › No notching effect - like for example with conical screw tips. › The levelling screw and the levelling disc are captively connected by a very simple system. › Problem-free changeover of the machine possible, as the complete levelling disc remains on the machine foot when the machine is lifted. 	

SE 55	3352981
--------------	---------

- › Jackscrew M12 x 1 x 150
- › Maximum load: 600 kg

SE 85	3352982
--------------	---------

- › Jackscrew M16 x 1 x 150
- › Maximum load: 1 500 kg





Clamping block set 16-05	3440653
--------------------------	---------

- Lathes: TU 3008 / TH 3309 / TH 3610
- > 1 pc. clamping block SLTBN 16-05
 - > 1 pc. parting off tool SLIH 26-2
 - > 1 pc. parting off tool SLIH 26-3
 - > 5 pcs. cutting inserts GTN2 (cutting width 2.2 mm)
 - > 5 pcs. cutting inserts GTN3 (cutting width 3.1 mm)
 - > Aluminium box

Clamping block set 20-05	3440654
--------------------------	---------

- Lathes: TH 4010 / TH 4210 / TH 46 / TH 56
- > 1 pc. clamping block SLTBN 20-05
 - > 1 pc. parting off tool SLIH 26-3
 - > 1 pc. parting off tool SLIH 26-4
 - > 5 pcs. cutting inserts GTN3 (cutting width 3.1 mm)
 - > 5 pcs. cutting inserts GTN4 (cutting width 4.1 mm)
 - > Aluminium box

Clamping block set 25-05	3440655
--------------------------	---------

- For lathes: TH 66 / TH 80
- > 1 pc. clamping block SLTBN 25-05
 - > 1 pc. parting off tool SLIH 26-3
 - > 1 pc. parting off tool SLIH 26-4
 - > 5 pcs. cutting inserts GTN3 (cutting width 3.1 mm)
 - > 5 pcs. cutting inserts GTN4 (cutting width 4.1 mm)
 - > Aluminium box

Replacement cutting insert set (10 pcs.)	
------------------------------------------	--

- | | |
|----------------------------------|---------|
| for cutting inserts GTN 2 | 3440663 |
| for cutting inserts GTN 3 | 3440664 |
| for cutting inserts GTN 4 | 3440665 |

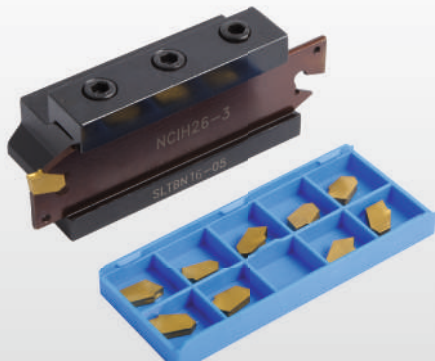

Clamping block set with clamping inserts and parting off tool

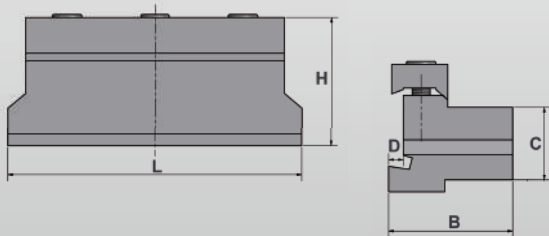

Clamping block	16-05	20-05	25-05
L x W x H	88 x 38 x 42 mm	88 x 38 x 43 mm	100 x 42 x 43,5 mm
C	16 mm	20 mm	25 mm
D	4 mm	5 mm	5 mm

Workplace mats – for dry and wet areas	Article no.
----------------------------------------	-------------

- > Fire-resistant
- > Made of polyurethane on polyether basis
- > Surface: nubbed
- > Underside: nubbed for maximum standing comfort and slip resistance
- > Thickness 14 mm
- > Colour anthracite
- > Temperature resistance -35°C to +95°C
- > Fire classification B1 as per DIN 4102
- > 5-year warranty



Work mat	6800000
Dimensions 1 840 x 640 mm	
Work mat	6800005
Dimensions 1 840 x 940 mm	
Work mat	6800001
Dimensions 3 040 x 640 mm	
Work mat	6800006
Dimensions 3 040 x 940 mm	

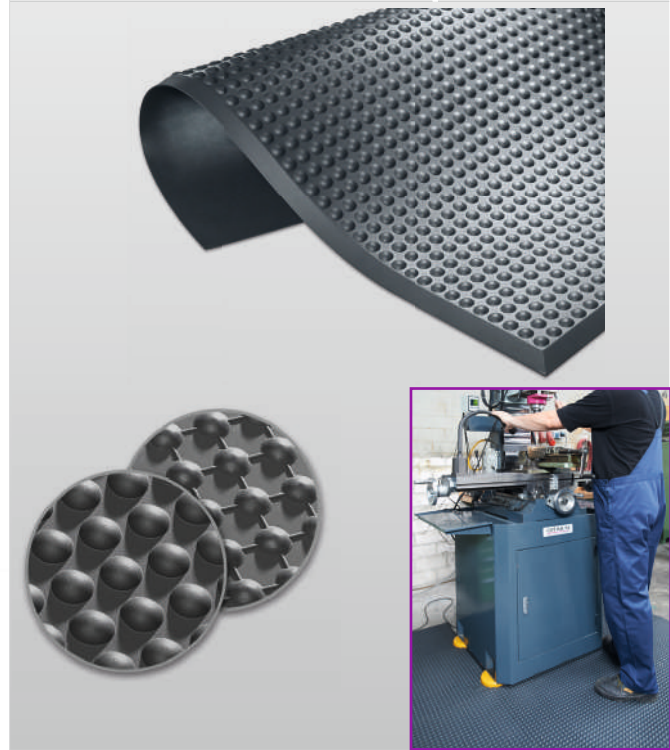

Twist drill HSS with morse taper	Article no.
----------------------------------	-------------

- > 9-part; sizes 14.5/16/18/20/22/24/26/28/30 mm
- > Long lifetime, good chip removal
- > Right handed

MT 2	3051002
MT 3	3051003



Accessories for lathes

Clamping disc	Article no.
Ø 170 mm for TU 2004V	3440295
Ø 220 mm for TU 2406	3440552
Ø 240 mm for TU 2506	3441352
Ø 265 mm for TU 2807	3441452
Ø 300 mm Camlock DIN ISO 702-2 No. 4	3442976
Ø 320 mm A 2-5	3442979
Ø 330 mm Camlock DIN ISO 702-2 No. 5	3442978
Ø 350 mm Camlock DIN ISO 702-2 No. 6	3442980
Ø 450 mm No. 8	3442982



Chuck flange	Article no.
› For lathe chuck assembly	
Ø 160 mm Camlock DIN ISO 702-2 No. 4	3441512
› for four-jaw lathe chucks Ø 160 mm	
Ø 200 mm Camlock DIN ISO 702-2 No. 4	3441513
› for four-jaw lathe chucks Ø 200 mm	
Ø 200 mm Camlock DIN ISO 702-2 No. 5	3441514
› for four-jaw lathe chucks Ø 200 mm	
Ø 200 mm Camlock DIN ISO 702-2 No. 6	3444012
› for four-jaw lathe chucks Ø 200 mm	
Ø 250 mm Camlock DIN ISO 702-2 No. 6	3444013
› for four-jaw lathe chucks Ø 250 mm	
Ø 315 mm Camlock DIN ISO 702-2 No. 8	3444041
› for three- and four-jaw lathe chucks Ø 315 mm	

Chuck flange	Article no.
› For lathe chuck assembly	
Ø 100 mm	3440312
› Cylindrical for TU 2004V	
Ø 125 mm	3440313
› Cylindrical for TU 2304	
Ø 125 mm	3440511
› Cylindrical for TU 2406	
Ø 125 mm	3441312
› Short taper for TU 2506 / TU 2807	
Ø 160 mm	3441413
› Short taper for TU 2807	

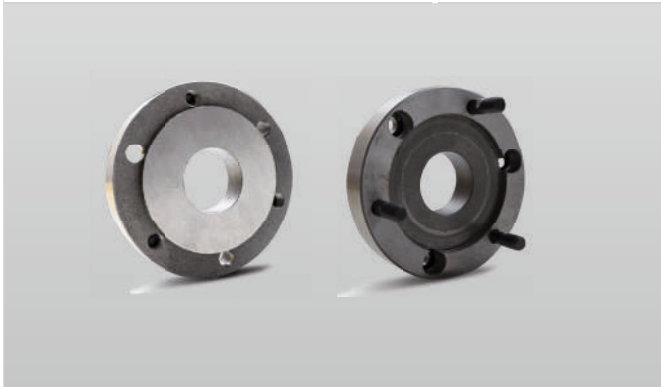

Collet chuck	Article no.
With short taper mount	
ER 16 Ø 22 mm	3440281
› Cylindrical for TU 1503V	
ER 25 Ø 72 mm	3440305
› Cylindrical for TU 2004V / TU 2304	
ER 25 Ø 52 mm	3440505
› Cylindrical for TU 2406	
ER 32 Ø 52 mm	3440506
› Cylindrical for TU 2406	
ER 25 Ø 52 mm	3441305
› Cylindrical for TU 2506 / TU 2807	
ER 32 Ø 52 mm	3441306
› Short taper for TU 2506 / TU 2807	



Collet chuck for collet type 5C 5C / 385E	
› as per DIN 6341	
› With spindle chuck as per DIN ISO 702-2	
› Concentricity 0.02 mm	
5C - Camlock no. 4	3441554
› a = 71 mm / Ø = 126 mm	
5C - Camlock Nr. 5	3441555
› a = 107.4 mm / Ø = 126 mm	
5C - Camlock no. 6	3441556
› a = 160 mm / Ø = 182 mm	
5C - Camlock no. 8	3441558
› a = 163 mm / Ø = 225 mm	

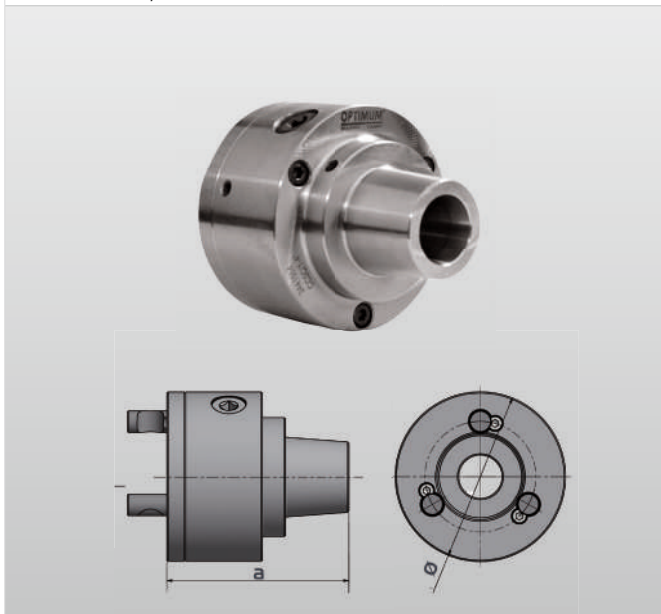

Travelling centre	Article no.
max. radial run-out 0.006 mm	
MT 1	3440701
> Max. speed 5 000 rpm; radial load max. 320 N	
MT 2	3440702
> Max. speed 5 000 rpm; radial load max. 400 N	
MT 3	3440703
> Max. speed 4 500 rpm; radial load max. 800 N	
MT 4	3440704
> Max. speed 3 500 rpm; radial load max. 1 250 N	
MT 5	3440705
> Max. speed 3 000 rpm; radial load max. 1 500 N	
MT 6	3440706
> Max. speed 2 500 rpm; radial load max. 1 800 N	



Collet kit SPZ - 5C	3441509
> 17-part, clamping range 3 - 25 mm	
> Norm 385 E	
> For universal collet chuck device	



Collet kit	Article no.
> DIN 6499	
ER 16	3440282
> 12-part, clamping range \varnothing 1 - 10 mm	
ER 25	3441109
> 15-part, clamping range \varnothing 1 - 16 mm	
ER 32	3441122
> 18-part, clamping range \varnothing 3 - 20 mm	



BISON ^g centre	Article no.
max. radial run-out 0.005 mm	
MT 2 (NSK ball roller bearings INA needle bearings)	3451002
> Max. speed 7 000 rpm; radial load max. 2 000 N	
MT 3 (NSK ball roller bearings INA needle bearings)	3451003
> Max. speed 5 000 rpm; radial load max. 4 000 N	
MT 4 (NSK ball roller bearings INA needle bearings)	3451004
> Max. speed 3 800 rpm; radial load max. 8 000 N	
MT 5 (2-row SKF angular contact bearings)	3451005
> Max. speed 3 000 rpm; radial load max. 20 000 N	

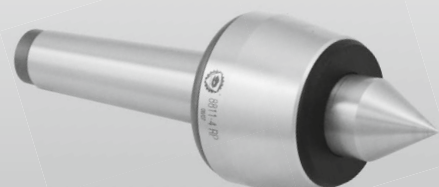

Travelling centre	Article no.
> With 7 replaceable tips	
> Body made of tempered and polished tool steel	
> Precision needle bearings guarantee excellent concentricity	
MT 2	3440732
MT 3	3440733
MT 4	3440734



Universal collet chuck device 5C	Article no.
> for lathe TH 3309	3441506
> for lathe TH 42 (not Vario)	3441507



Preface

Drilling

Milling

Turning accessories

Saws

Grinding

Polishing

Lamps

Measuring

Accessories for lathes

Universal coolant unit	3352002
› Motor output 100 Watt 230 V ~50 Hz	
› Delivery height max. 2 m	
› Flow rate 4.5 l/min	
› Container capacity 10 l	
› Complete with container, flexible tube and hose	
› With switch/plug combination	
› Magnetic base fastener for coolant hose	
› For self-assembly!	



Fixed steady	Article no.
for TU 1503V	3440211
› a = Ø 40 mm; b = 145 mm; c = 70.5 mm	
for TU 2004V	3440231
› a = Ø 50 mm; b = 200 mm; c = 100 mm	
for TU 2304 / TU 2304V	3440361
› a = Ø 55 mm; b = 220 mm; c = 115 mm	
for TU 2406 / TU 2506	3441315
› a = Ø 50 mm; b = 245 mm; c = 125 mm	
for TU 2807 / TU 2807V	3441415
› a = Ø 55 mm; b = 250 mm; c = 140 mm	
for TU 3008 / TU 3008G / TU 3008V	3441461
› a = Ø 60 mm; b = 260 mm; c = 157 mm	

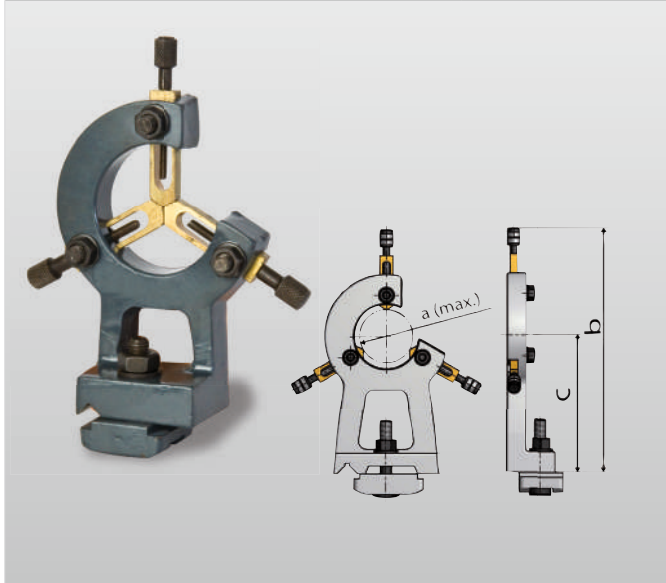

Travelling steady	Article no.
for TU 1503V	3440210
› a = Ø 45 mm; b = 155 mm; c = 76 mm	
for TU 2004V	3440230
› a = Ø 40 mm; b = 195 mm; c = 100 mm	
for TU 2304 / TU 2304V	3440360
› a = Ø 34 mm; b = 200 mm; c = 97 mm	
for TU 2406 / TU 2506	3441310
› a = Ø 34 mm; b = 220 mm; c = 107 mm	
for TU 2807 / TU 2807V	3441410
› a = Ø 56 mm; b = 250 mm; c = 130 mm	
for TU 3008 / TU 3008G / TU 3008V	3441460
› a = Ø 60 mm; b = 255 mm; c = 151 mm	

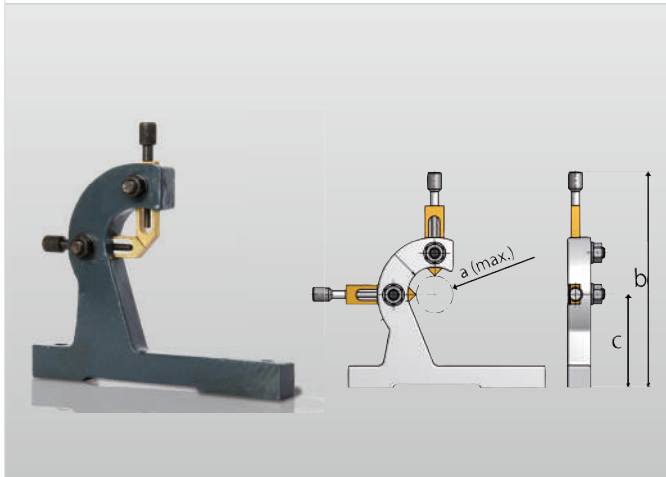

NEW AQUACUT C1	3530030
• 10 litre cannister	
• For mixing emulsions	
• Cooling emulsion	
• High-pressure resistant and containing mineral oil, for long tool life and clean surfaces	
• Emulsifiable with water, microbe-resistant and kind to the skin	



You will find more coolant accessories from page 242

Position stop With fine adjustment	Article no.
› for lathe TH 3309	3441522
› for lathe TH 3610	3441523
› for lathe TH 46	3444022
› for lathe TH 56	3444023





METAL-CUTTING BAND SAWS



Stationary machines
Page 196 - Page 207



Transportable machines
Page 208 - Page 213

Manual metal-cutting circular saws for steel, iron, light alloys, solid materials and sections

Facts that impress in terms of quality, performance and price

- ▶ Swivel range of $\pm 45^\circ$
- ▶ Easily readable angle scale supports precise work
- ▶ Mitre adjustment within seconds
- ▶ Protected vice spindle
- ▶ Solid machine chassis with drill holes on both sides for attaching the MSR material stand
- ▶ Long handle supports sawing without applying excessive force, includes integrated pushbutton (on/off)
- ▶ Automatic coolant pump switch-on during sawing
- ▶ Functional protection device, closed design, mobile
- ▶ Fast opening mechanism for optimal safety during cutting
- ▶ Centrally clamping vise, 4x guided with individually adjustable clamping jaws Cut always occurs in optimal position relative to workpiece
- ▶ Solid machine chassis
- ▶ Protected vice spindle
- ▶ Machine chassis sizes:
 - CS 275 - 460 x 515 x 775 mm and
 - CS 315 - 546 x 620 x 801 mm
- ▶ The saw is delivered without a circular saw blade (saw blade division freely selectable)

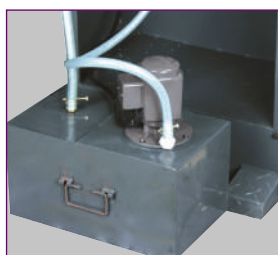

Coolant pump
 › Removable coolant tank
 › Integrated powerful pump



Fig.: CS 315

Material supports	Article no.
MSR 4	3357610
MSR 4H	3357001
MSR 7	3357611
MSR 7H	3357002
MSR 10	3357613
MSR 10H	3357003



Information*MSR 4 / MSR 7 / MSR 10" on page 214

Technical specifications, accessories and dimensions



Model	CS 275	CS 315
Article no.	3302275	3302300
Technical specifications		
Electrical connection	400 V / 3 Ph ~50 Hz	400 V / 3 Ph ~50 Hz
Motor output	1.4 / 2.0 kW	0.75 / 1.5 kW
Coolant pump motor	40 W	
General instructions		
Cutting angle	-45° to +45°	
Cutting angle adjustment	Via rotating bearing block	
Feed	manual	
Cutting speed	41 / 82 rpm	19 / 38 rpm
Saw blade diameter	Ø 275 mm Internal Ø 40 mm	Ø 315 mm Internal Ø 40 mm
Vice jaw width	110 mm	135 mm
Dimensions		
Length	460 mm	560 mm
Width	830 mm	902 mm
Height	1 700 mm	1 765 mm
Weight	175 kg	235 kg

Scope of supply

- › Coolant system
- › Machine chassis

Cutting areas				
				
CS 275	0°	Ø 60 mm	60 mm	60 x 100 mm
CS 315		Ø 85 mm	85 mm	70 x 130 mm
CS 275	45°	Ø 60 mm	60 mm	60 x 70 mm
CS 315		Ø 85 mm	85 mm	70 x 90 mm



Circular saw blades - information

4 mm/T:    tube/sections (wall thickness)

- › up to 1 mm: Aluminium/Bronze/Copper/Brass
- › up to 1.5 mm: steels up to 1 500 N/m²/stainless steels
- › up to 2 mm: Steels up to 1 200 N/m²

6 mm/T:    tube/sections (wall thickness)



- › up to 1.5 mm: Aluminium/Bronze/Copper/Brass
- › as of 3 mm: Steels up to 1 800 N/m²

6 mm/T:   solid materials (cross-section)

- › 10-20 mm: Aluminium/Bronze/Copper/Brass
- › 20-40 mm: Steels up to 1 800 N/m²/stainless steels

8 mm/T:    tube/sections (wall thickness)

- › as of 3 mm: Aluminium/Bronze/Copper/Brass

8 mm/T:   solid materials (cross-section)

- › 20-40 mm: Steels up to 1 800 N/m²: Aluminium/Bronze/Copper
- › 40-60 mm: Steels up to 1 200 N/m²/stainless steels

Dimensions

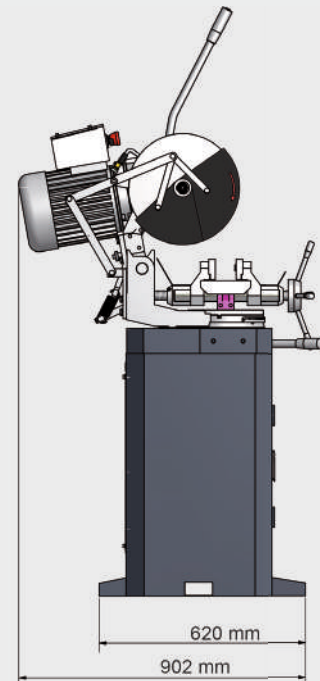
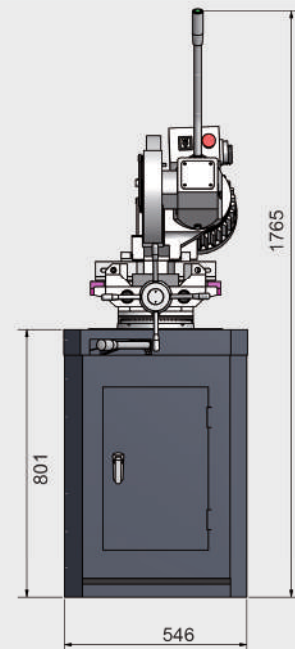

Metal-cutting circular saw blade CS 275

mm/per tooth	Teeth	Blade width	Article no.
4 mm/T	220 teeth	2.5 mm	3357444
6 mm/T	140 teeth	2.5 mm	3357446
8 mm/T	110 teeth	2.5 mm	3357448

CS 315

4 mm/T	240 teeth	2.5 mm	3357454
6 mm/T	150 teeth	2.5 mm	3357456
8 mm/T	120 teeth	2.5 mm	3357458



Preface

Drilling

Milling

Turning

Saws

Grinding

Polishing

Lamps

Measuring

Semi-automatic double mitre metal cutting band saw with inverter Vario drive

Facts that impress in terms of quality, performance and price

- ▶ Heavy-duty industrial design
- ▶ Low-noise running action
- ▶ Manual or semi-automatic operation
- ▶ Saw band speed continuously adjustable from 0 to 80 m/min.
- ▶ Excellent cutting precision thanks to vibration-free action
- ▶ Mitre adjustment to 60° by pivoting the entire saw head
- ▶ Equipped as a factory standard with bi-metal saw blade
- ▶ End stops adjustable to degree accuracy
- ▶ Chip brush
- ▶ Microswitch for automatic limit position cut-off
- ▶ Roller support adjustable for long and heavy workpieces
- ▶ Coolant pump
- ▶ Ball bearing borne saw band guide with carbide shims for optimal cutting results
- ▶ Easy adjustment of the lowering speed via feed control valve in control panel
- ▶ Generously dimensioned, hydraulic quick-action vice, self-closing, adjustable for large cross-sections
- ▶ Machine with full equipment set; the user can immediately start productive work



Saw band tension

- > Easy and correct adjustment of the saw band tension by pressure gauge

Semi-automatic operating mode



- ▶ Vice closes and motor is activated
- ▶ Lower the saw head to cut
- ▶ Motor stops and saw head returns to original position



Fig.: SD 350AV

Technical specifications, accessories and dimensions

Model	SD 350AV
Article no.	3292355
Technical specifications	
Electrical connection	400 V / 3 Ph ~50 Hz
Total rated value	3.8 kW
Saw motor	2.2 kW
Hydraulic pump	1.4 kW
Coolant pump motor	50 W
General instructions	
Lifting the saw head	
› Manual operation	Hydraulic via pushbutton
› Semi-automatic operation	automatic
Feed	continuously variable
Saw band speed	0 - 70 m/min
Saw band dimensions	2 925 x 27 x 0.9 mm
Cutting angle	-45° to 60°
Dimensions	
Length	1 750 mm
Width without/with material stop	1 075 / 1 415 mm
Height bottom/top limit position	1 420 / 2 000 mm
Weight	600 kg

Cutting areas			
			
0°	∅ 270 mm	230 mm	230 x 350 mm
45°	∅ 230 mm	200 mm	210 x 220 mm
60°	∅ 140 mm	140 mm	140 x 220 mm
-45°	∅ 230 mm	170 mm	140 x 200 mm

The cutting area was determined for a full section.
The cutting range can be larger in case of cut-off sections.

Saw bands HSS bi-metal M 42			
Teeth per inch	Tooth angle	Article no.	
5 - 8 tpi	0°	3357541	
4 - 6 tpi	6°	3357540	
6 - 10 tpi	0°	3357542	
10 - 14 tpi	0°	3357543	
Saw band set HSS bi-metal M 42			
1 pc. saw band 6 - 10 tpi; 0°			3357501
1 pc. saw band 5 - 8 tpi; 0°			
1 pc. saw band 4 - 6 tpi; 6°			
„General saw band information“ on page 216			

AQUACUT C1	3530030
› For mixing emulsions, for cooling along the cut	
› 10 litres	

Material supports		Article no.
MSR 4H	L x W 1 000 x 440 mm	3357001
MSR 7H	L x W 2 000 x 440 mm	3357002
MSR 10H	L x W 3 000 x 440 mm	3357003
Table extension MSR 1		3357006
PVC rollers for MSR		3357609

Important information on „Operation of machines with frequency converters“ on page 249
The metal-cutting bandsaw (frequency converter) complies with the DIN EN 55011:2011-04 standard: class C3



Dimensions

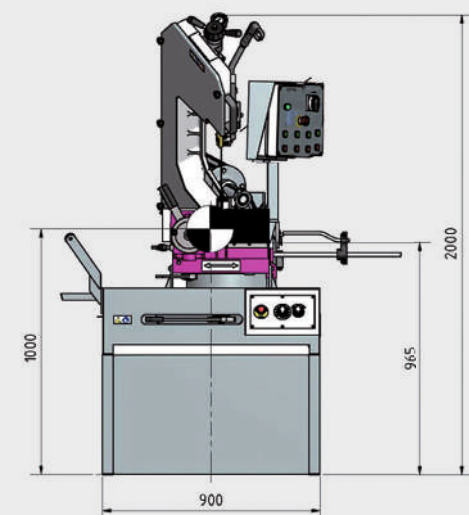
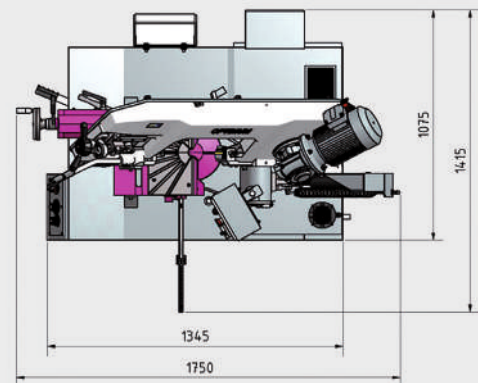
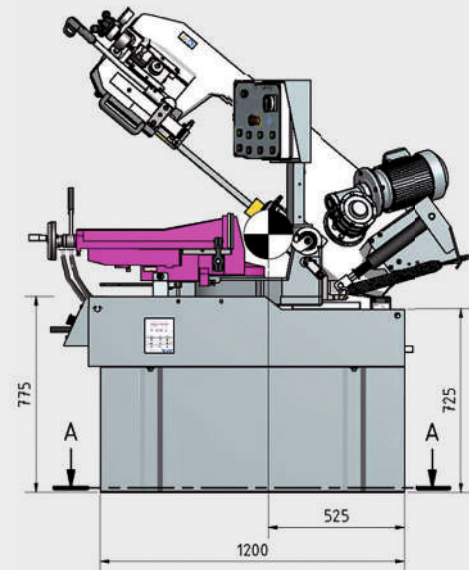

Scope of supply

- › Material stop
- › Bi-metal saw band
- › Machine chassis

Preface

Drilling

Milling

Turning

Saws

Grinding

Polishing

Lamps

Measuring

Metal-cutting band saw with double mitre in heavy-duty design

Facts that impress in terms of quality, performance and price

- ▶ Heavy-duty industrial design
- ▶ Low-noise running action
- ▶ Excellent cutting precision thanks to vibration-free action
- ▶ Two switchable speeds 36/72 m/min.
- ▶ Mitre adjustment to -60° by pivoting the entire saw head
- ▶ Generously dimensioned, rugged quick clamping vice, adjustable via hand wheel Workpiece is clamped using a handy quick-clamping lever
- ▶ Quick clamping vice movable for large materials
- ▶ Easy and accurate adjustment of the saw band tension by pressure gauge
- ▶ Equipped as a factory standard with bi-metal saw blade
- ▶ End stops adjustable to degree accuracy
- ▶ Chip brush
- ▶ Ball bearing borne saw band guide with carbide shims for optimal cutting results
- ▶ Precise, continuously adjustable saw band movement via hydraulic cylinder
- ▶ Coolant pump
- ▶ Easy adjustment of the lowering speed via feed control valve in control panel
- ▶ Emergency stop button
- ▶ Rugged machine chassis
- ▶ Microswitch for automatic limit position cut-off
- ▶ Roller support adjustable for long and heavy workpieces
- ▶ Fully equipped; the user can immediately start productive work after commissioning



Fig.: S 350DG



Technical specifications, accessories and dimensions

Model	S 350DG
Article no.	3290350
Technical specifications	
Electrical connection	400 V / 3 Ph ~50 Hz
Motor output	2.2 kW
Coolant pump motor	50 W
General instructions	
Lifting the saw head	manual
Feed	continuously variable
Saw band speed	36/72 m/min.
Saw band dimensions	2 925 x 27 x 0.9 mm
Cutting angle	-45° to 60°
Dimensions	
Length	1 750 mm
Width without/with material stop	1 075 / 1 415 mm
Height bottom/top limit position	1 420 / 2 000 mm
Weight	550 kg

Scope of supply

- > Material stop
- > Bi-metal saw band
- > Machine chassis
- > Coolant pump

Cutting areas

			
0°	Ø 270 mm	230 mm	230 x 350 mm
45°	Ø 230 mm	200 mm	210 x 220 mm
60°	Ø 140 mm	140 mm	140 x 220 mm
-45°	Ø 230 mm	170 mm	140 x 200 mm

The cutting area was determined for a full section.
The cutting range can be larger in case of cut-off sections.

Saw bands HSS bi-metal M 42

Teeth per inch	Tooth angle	Article no.
5 - 8 tpi	0°	3357541
4 - 6 tpi	6°	3357540
6 - 10 tpi	0°	3357542
10 - 14 tpi	0°	3357543

Saw band set HSS bi-metal M 42

1 pc. saw band 6 - 10 tpi; 0°	3357501
1 pc. saw band 5 - 8 tpi; 0°	
1 pc. saw band 4 - 6 tpi; 6°	

„General saw band information“ on page 216

AQUACUT C1

3530030

- > For cooling the cut
- > 10 litres

Material supports

	Article no.
MSR 4H L x W 1 000 x 440 mm	3357001
MSR 7H L x W 2 000 x 440 mm	3357002
MSR 10H L x W 3 000 x 440 mm	3357003
Table extension MSR 1	3357006
PVC rollers for MSR	3357609



Dimensions

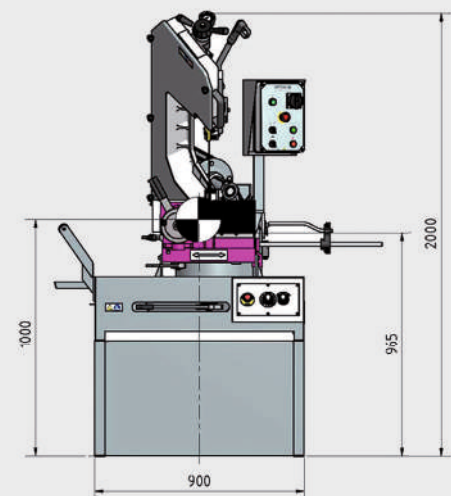
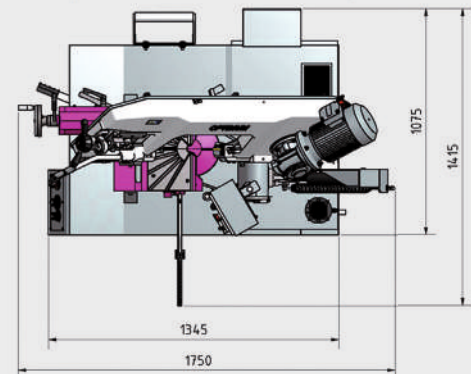
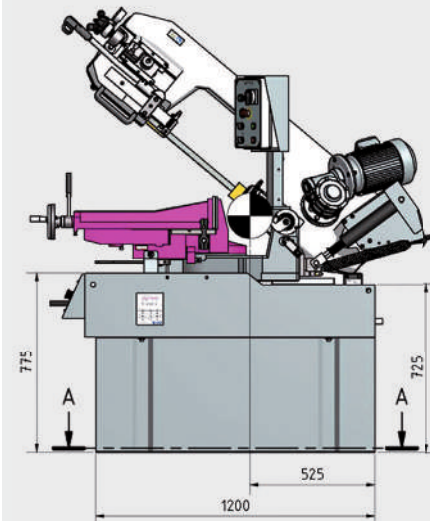

Preface

Drilling

Milling

Turning

Saws

Grinding

Polishing

Lamps

Measuring

Band saw for metal working with pivoting saw head. S 300DG Vario with continuously adjustable saw band speed

Facts that impress in terms of quality, performance and price

- ▶ Low-noise running action
- ▶ Heavy cast design
- ▶ Excellent cutting precision thanks to vibration-free action
- ▶ Ball-bearing borne saw band guide
- ▶ Chip brush
- ▶ Microswitch for automatic limit position cut-off
- ▶ Pushbutton - manual saw band run - on the lever switches the saw band run on and off
- ▶ Equipped as a factory standard with bi-metal saw blade
- ▶ Material stop with scaling
- ▶ Quick clamping vice, adjustable via hand wheel. Workpiece is clamped using a handy quick-clamping lever
- ▶ Rugged machine chassis
- ▶ End stops adjustable to degree accuracy

S 300DG Vario

- ▶ Saw band speed continuously adjustable from 20 to 90 m/min.



Pressure gauge

- > Easy and correct adjustment of the saw band tension



Coolant pump

- > Powerful 100 W



Roller support

- > For supporting long materials





Fig.: S 300DG

Scope of supply

- > Material stop
- > Bi-metal saw band
- > Machine chassis
- > Coolant pump

Model	S 300DG
Article no.	3290290
Model	S 300DG Vario*
Article no.	3290295

Technical specifications	
Electrical connection	400 V / 3 Ph ~50 Hz
Motor output	1.5 kW
Coolant pump motor	100 W
General instructions	
Lifting the saw head	manual
Feed	continuously variable
Saw band speed	35/70 m/min.
Vario saw band speed	20 - 90 m/min
Saw band dimensions	2 750 x 27 x 0.9 mm
Cutting angle	45° to -60°
Dimensions	
Length	1 680 mm
Width without/with material stop	700 / 1 300 mm
Height bottom/top limit position	1 600 / 1 850 mm
Weight	335 kg

	Cutting areas		
			
0°	Ø 255 mm	190 mm	190 x 310 mm
45°	Ø 215 mm	190 mm	190 x 200 mm
-60°	Ø 135 mm	135 mm	135 x 135 mm
-45°	Ø 220 mm	190 mm	135 x 190 mm

The cutting area was determined for a full section.
The cutting range can be larger in case of cut-off sections.

AQUACUT C1	3530030
> For cooling the cut	
> 10 litres	

Saw bands HSS bi-metal M 42		
Teeth per inch	Tooth angle	Article no.
5 - 8 tpi	0°	3357751
5 - 8 tpi	10°	3357752
6 - 10 tpi	0°	3357753
10 - 14 tpi	0°	3357754
Saw band set HSS bi-metal M 42		3357700
1 pc. saw band 6 - 10 tpi; 0°		
1 pc. saw band 5 - 8 tpi; 0°		
1 pc. saw band 5 - 8 tpi; 10°		

„General saw band information“ on page 216

Important information on transport surcharge and „Operation of machines with frequency converters“ on page 249

The metal-cutting bandsaw (frequency converter) complies with the DIN EN 55011 standard: class C3

Metal-cutting band saw with turntable and pivoting saw head for economic and precise work

Facts that impress in terms of quality, performance and price

- ▶ Low-noise running action
- ▶ Heavy cast design
- ▶ Carbide guide
- ▶ Excellent cutting precision thanks to vibration-free action
- ▶ Saw band speed continuously adjustable via frequency inverter
- ▶ Professional inverter technology
- ▶ High motor output even at low speeds
- ▶ Microswitch for automatic limit position cut-off
- ▶ Precise, re-adjustable and durable saw band guide
- ▶ End stops adjustable to degree accuracy
- ▶ Chip brush
- ▶ Coolant pump
- ▶ Quick clamping vice, adjustable via hand wheel. Workpiece is clamped using a handy quick-clamping lever
- ▶ Rugged machine chassis
- ▶ Control unit facilitates machine setup
- ▶ Fully equipped; the user can immediately start productive work after commissioning

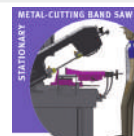

Pressure gauge

- › Easy and accurate adjustment of the saw band tension

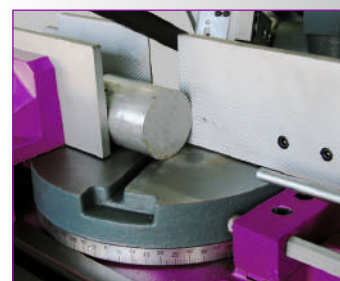



Turntable

- › Any angle between 45° and -60° can be sawed as the cutting gap pivots with the saw arm
- › Easily legible angle scale

Scope of supply

- › Material stop
- › Bi-metal saw band
- › Machine chassis
- › Coolant pump

Cutting areas

			
0°	Ø 255 mm	255 mm	200 x 270 mm
45°	Ø 190 mm	160 mm	160 x 160 mm
-60°	Ø 110 mm	110 mm	110 x 210 mm
-45°	Ø 190 mm	140 mm	140 x 210 mm

The cutting area was determined for a full section. The cutting range can be larger in case of cut-off sections.

Model	S 310DG Vario
Article no.	3290335
Technical specifications	
Electrical connection	400 V / 3 Ph ~50 Hz
Motor output	1.5 kW
Coolant pump motor	100 W
General instructions	
Lifting the saw head	manual
Feed	continuously variable
Saw band speed	20 - 90 m/min
Saw band dimensions	2 750 x 27 x 0.9 mm
Cutting angle	45° to -60°
Dimensions	
Length	1 680 mm
Width without/with material stop	700 / 1 330 mm
Height bottom/top limit position	1 600 / 2 000 mm
Weight	380 kg

AQUACUT C1	3530030
› For cooling the cut	
› 10 litres	

Saw bands HSS bi-metal M 42		
Teeth per inch	Tooth angle	Article no.
5 - 8 tpi	0°	3357751
5 - 8 tpi	10°	3357752
6 - 10 tpi	0°	3357753
10 - 14 tpi	0°	3357754
Saw band set HSS bi-metal M 42		3357700
1 pc. saw band 6 - 10 tpi; 0°		
1 pc. saw band 5 - 8 tpi; 0°		
1 pc. saw band 5 - 8 tpi; 10°		
„General saw band information“ on page 216		

Metal-cutting band saw with pivoting saw head and continuously adjustable saw band speed

Facts that impress in terms of quality, performance and price

- ▶ Low-noise running action
- ▶ Rugged cast design
- ▶ Excellent cutting precision thanks to vibration-free action
- ▶ Variable cutting speeds
- ▶ Saw band lowering via hydraulic cylinder continuously adjustable by throttle valve
- ▶ Powerful 100 Watt coolant system
- ▶ Carbide guide
- ▶ Microswitch for automatic limit position cut-off
- ▶ Clear-cut keyboard for ease of use
- ▶ Ball-bearing borne saw band guide
- ▶ Quick clamping vice, adjustable via hand wheel. Workpiece is clamped using a handy quick-clamping lever
- ▶ Easily legible scale for adjusting the angle
- ▶ Equipped as a factory standard with bi-metal saw blade
- ▶ Adjustable material stop for batch work



Pressure gauge
 > Easy and accurate adjustment of the saw band tension



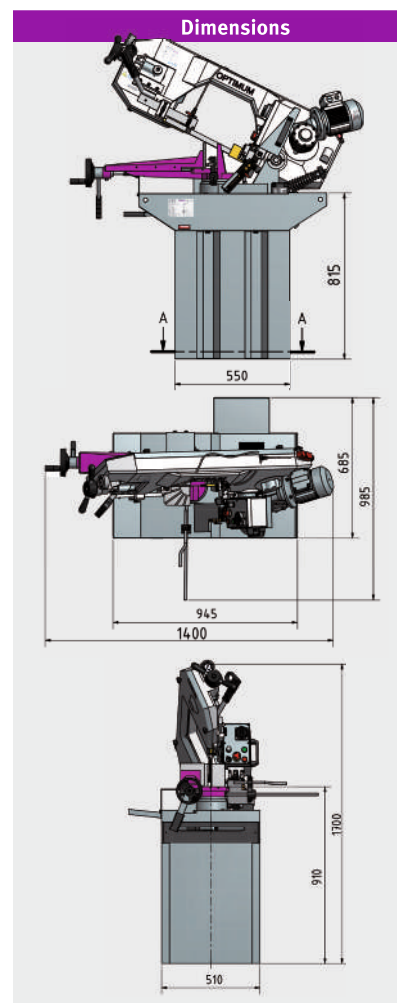

Fig.: SD 280V



Scope of supply

- > Material stop
- > Bi-metal saw band
- > Machine chassis
- > Coolant pump

Cutting areas

			
0°	Ø 225 mm	190 mm	150 x 235 mm
45°	Ø 155 mm	155 mm	155 x 210 mm
60°	Ø 90 mm	90 mm	90 x 120 mm

The cutting area was determined for a full section.
 The cutting range can be larger in case of cut-off sections.

Model	SD 280V
Article no.	3300280
Technical specifications	
Electrical connection	400 V / 3 Ph ~50 Hz
Motor output	1.5 kW
Coolant pump motor	100 W
General instructions	
Lifting the saw head	manual
Feed	continuously variable
Saw band speed	20 - 90 m/min
Saw band dimensions	2 480 x 27 x 0.9 mm
Cutting angle	0° to 60°
Dimensions	
Length	1 400 / 1 700 mm
Width without/with material stop	685 / 985 mm
Height bottom/top limit position	1 300 / 1 700 mm
Weight	185 kg

AQUACUT C1	3530030
> For cooling the cut	
> 10 litres	

Saw bands HSS bi-metal M 42		
Teeth per inch	Tooth angle	Article no.
5 - 8 tpi	0°	3357511
5 - 8 tpi	6°	3357512
6 - 10 tpi	0°	3357524
10 - 14 tpi	0°	3357525
Saw band set HSS bi-metal M 42		
1 pc. saw band 6 - 10 tpi; 0°		3357504
1 pc. saw band 5 - 8 tpi; 0°		
1 pc. saw band 5 - 8 tpi; 6°		

„General saw band information“ on page 216

Metal-cutting band saw with pivoting saw head for economic and precise work

Facts that impress in terms of quality, performance and price

- ▶ Low-noise running action
- ▶ Heavy cast design
- ▶ Excellent cutting precision thanks to vibration-free action
- ▶ Ball-bearing borne saw band guide
- ▶ Chip brush
- ▶ Automatic saw switch-off after completing the cut
- ▶ Rugged machine chassis
- ▶ Generously dimensioned control unit
- ▶ Equipped as a factory standard with bi-metal saw blade
- ▶ Material stop with scaling
- ▶ Quick clamping vice, adjustable via hand wheel. Workpiece is clamped using a handy quick-clamping lever
- ▶ End stops adjustable to degree accuracy
- ▶ Fully equipped; the user can immediately start productive work after commissioning

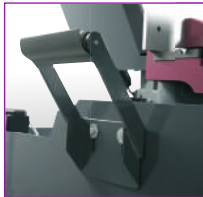

Roller support
 › For supporting long materials



Fig.: S 285DG

Model	S 285DG
Article no.	3300285
Technical specifications	
Electrical connection	400 V / 3 Ph ~50 Hz
Motor output	1.1 kW
Coolant pump motor	100 W
General instructions	
Lifting the saw head	manual
Feed	continuously variable
Saw band speed	45 / 90 m/min
Saw band dimensions	2 480 x 27 x 0.9 mm
Cutting angle	-45° to 60°
Dimensions	
Length	1 720 mm
Width without/with material stop	870 / 1 270 mm
Height bottom / top limit position	1 280 / 1 800 mm
Weight	295 kg



Pressure gauge
 › Easy and accurate adjustment of the saw band tension



Coolant pump
 › Powerful 100 W

Scope of supply

- › Material stop
- › Bi-metal saw band
- › Machine chassis
- › Coolant pump

Cutting areas

0°	Ø 225 mm	180 mm	150 x 245 mm
45°	Ø 150 mm	150 mm	150 x 190 mm
60°	Ø 90 mm	90 mm	90 x 180 mm
-45°	Ø 150 mm	150 mm	120 x 150 mm

The cutting area was determined for a full section.
 The cutting range can be larger in case of cut-off sections.

AQUACUT C1

3530030

- › For cooling the cut
- › 10 litres

Saw bands HSS bi-metal M 42

Teeth per inch	Tooth angle	Article no.
5 - 8 tpi	0°	3357511
5 - 8 tpi	6°	3357512
6 - 10 tpi	0°	3357524
10 - 14 tpi	0°	3357525
Saw band set HSS bi-metal M 42		3357504
1 pc. saw band 6 - 10 tpi; 0°		
1 pc. saw band 5 - 8 tpi; 0°		
1 pc. saw band 5 - 8 tpi; 6°		

„General saw band information“ on page 216



Metal band saw with pivoting saw head. S 275NV with continuously adjustable saw band speed

Facts that impress in terms of quality, performance and price

- ▶ Low-noise running action
- ▶ Rugged cast design
- ▶ Excellent cutting precision thanks to vibration-free action
- ▶ Saw band lowering via hydraulic cylinder continuously adjustable by throttle valve
- ▶ Microswitch for automatic limit position cut-off
- ▶ Coolant system
- ▶ Equipped as a factory standard with bi-metal saw blade
- ▶ Adjustable material stop for batch work
- ▶ Rugged machine chassis
- ▶ Ball-bearing borne saw band guide
- ▶ Quick clamping vice, adjustable via hand wheel. Workpiece is clamped using a handy quick-clamping lever
- ▶ Easily legible scale for adjusting the angle
- ▶ Overload protection

S 275N

- ▶ Motor circuit switch
- ▶ Two switchable speeds

S 275NV

- ▶ Saw band speed continuously adjustable from 20 to 90 m/min.
- ▶ Speed change possible during operation

Pressure gauge

- › Easy and accurate adjustment of the saw band tension



Fig.: S 275N

Dimensions

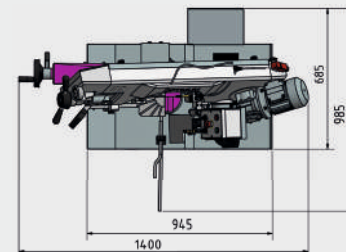
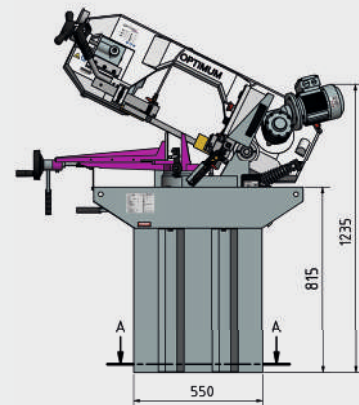

Scope of supply

- › Material stop
- › Bi-metal saw band
- › Machine chassis
- › Coolant pump

Cutting areas

0°	Ø 225 mm	170 mm	150 x 245 mm
45°	Ø 145 mm	145 mm	145 x 180 mm
60°	Ø 90 mm	90 mm	90 x 120 mm

The cutting area was determined for a full section.
The cutting range can be larger in case of cut-off sections.

Model	S 275N	S 275NV
Article no.	3300260	3300265
Technical specifications		
Electrical connection	400 V / 3 Ph ~50 Hz	230 V / 1 Ph ~50 Hz
Motor output	1.1 kW	1.5 kW
Coolant pump motor	90 W	
General instructions		
Lifting the saw head	manual	
Feed	continuously variable	
Saw band speed	45 / 90 m/min	20 - 90 m/min
Saw band dimensions	2 480 x 27 x 0.9 mm	
Cutting angle	0° to 60°	
Dimensions		
Length	1 400 mm	
Width without/with material stop	685 mm / 985 mm	
Height bottom/top limit position	1 235 mm / 1 700 mm	
Weight	185 kg	

AQUACUT C1	3530030
› For cooling the cut	
› 10 litres	

Saw bands HSS bi-metal M 42		
Teeth per inch	Tooth angle	Art.no.
5 - 8 tpi	0°	3357511
5 - 8 tpi	6°	3357512
6 - 10 tpi	0°	3357524
6 - 10 tpi	6°	3357510
10 - 14 tpi	0°	3357525
Saw band set HSS bi-metal M 42		3357504
1 pc. Saw band 6 - 10 tpi; 6°		
1 pc. Saw band 5 - 8 tpi; 0°		
1 pc. Saw band 5 - 8 tpi; 6°		

„General saw band information“ on page 216

Metal-cutting band saw with pivoting saw head and two saw band speeds

Facts that impress in terms of quality, performance and price

- ▶ Low-noise running action
- ▶ Rugged cast design
- ▶ Excellent cutting precision thanks to vibration-free action
- ▶ Two switchable speeds
- ▶ Saw band lowering via hydraulic cylinder continuously adjustable by throttle valve
- ▶ Microswitch for automatic limit position cut-off
- ▶ Easily legible scale for adjusting the angle
- ▶ Coolant system
- ▶ Rugged machine chassis
- ▶ Ball-bearing borne saw band guide
- ▶ Quick clamping vice, adjustable via hand wheel. Workpiece is clamped using a handy quick-clamping lever
- ▶ Equipped as a factory standard with bi-metal saw blade
- ▶ Adjustable material stop for batch work
- ▶ Fully equipped; the user can immediately start productive work after commissioning



Fig. S 210

Model	S 210G
Article no.	3300210
Technical specifications	
Electrical connection	400 V / 3 Ph ~50 Hz
Motor output	750 W
Coolant pump motor	90 W
General instructions	
Lifting the saw head	manual
Feed	continuously variable
Saw band speed	40 / 80 m/min
Saw band dimensions	2 080 x 20 x 0.9 mm
Cutting angle	0° to 45°
Dimensions	
Length of closed/open vise	1 200 / 1 310 mm
Width without/with material stop	685 / 985 mm
Height bottom/top limit position	1 320 / 1 550 mm
Weight	152 kg

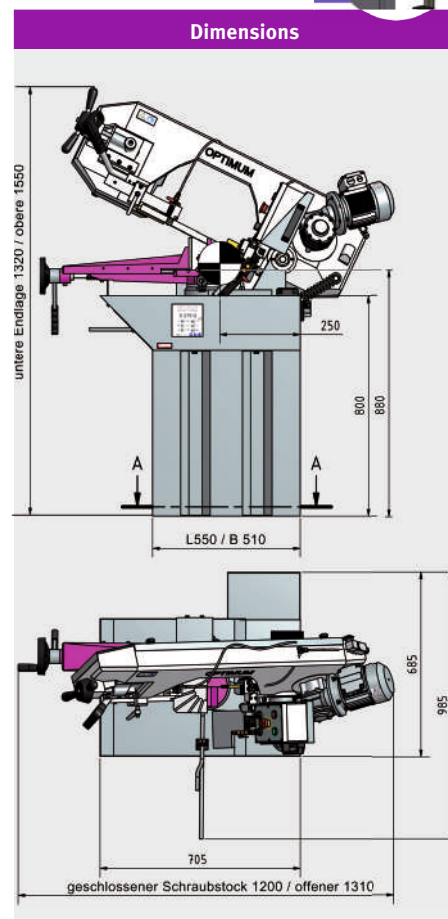

Scope of supply

- › Material stop
- › Bi-metal saw band
- › Machine chassis
- › Coolant pump

Cutting areas

0°	Ø 170 mm	140 mm	140 x 190 mm
45°	Ø 125 mm	125 mm	95 x 140 mm

The cutting area was determined for a full section.
The cutting range can be larger in case of cut-off sections.

AQUACUT C1

3530030

- › For cooling the cut
- › 10 litres

Saw bands HSS bi-metal M 42

Teeth per inch	Tooth angle	Article no.
5 - 8 tpi	0°	3357503
5 - 8 tpi	6°	3357505
6 - 10 tpi	0°	3357514
10 - 14 tpi	0°	3357515

Saw band set HSS bi-metal M 42

1 pc. saw band 6 - 10 tpi; 0°	3357502
1 pc. saw band 5 - 8 tpi; 0°	
1 pc. saw band 5 - 8 tpi; 10°	

„General saw band information“ on page 216

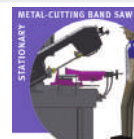

Preface

Drilling

Milling

Turning

Saws

Grinding

Polishing

Lamps

Measuring

The metal-cutting band saw for challenging sawing tasks. With drive belt and 4 sawing speeds



Facts that impress in terms of quality, performance and price

- ▶ Low-noise running action
- ▶ Rugged cast design
- ▶ Saw band lowering via hydraulic cylinder continuously adjustable by throttle valve
- ▶ Microswitch for automatic limit position cut-off
- ▶ Easily legible scale for adjusting the angle
- ▶ Equipped as a factory standard with bi-metal saw blade
- ▶ Saw band tensioning at front, adjustable via handwheel
- ▶ Ball-bearing borne saw band guide
- ▶ Rugged machine chassis with large wheels and handy transport bar allows trouble-free relocation of the machine
- ▶ Adjustable material stop for batch work
- ▶ Circuit breaker for belt cover
- ▶ Fully equipped; the user can immediately start productive work after commissioning



Four speeds

Adjustable by shifting the drive belt



Quick clamping vice

> Clamping jaws adjustable from 0° to 45° for mitre cuts



Coolant equipment

> Integrated in chassis
> Tank capacity 11 litres

Scope of supply



- > Material stop
- > Bi-metal saw band
- > Machine chassis

Model	S 181
Article no.	3300181

Technical specifications	
Electrical connection	400 V / 3 Ph ~50 Hz
Motor output	750 W
Coolant pump motor	90 W

General instructions	
Lifting the saw head	manual
Feed	continuously variable
Saw band speed	21 / 33.5 / 45 / 50 m/min
Saw band dimensions	2 362 x 19 x 0.9 mm
Cutting angle	0° to 45°

Dimensions	
Length	1 295 mm
Width	
Without material stop	450 mm
With material stop	600 mm
Height	
Saw head bottom limit position	1 060 mm
Saw head top limit position	1 550 mm
Weight	130 kg

Cutting areas			
			
0°	Ø 180 mm	180 mm	180 x 240 mm 50 x 300 mm
45°	Ø 110 mm	150 mm	110 x 170 mm

The cutting area was determined for a full section.
The cutting range can be larger in case of cut-off sections.

Saw bands HSS bi-metal M 42		
Teeth per inch	Tooth angle	Article no.
5 - 8 tpi	0°	3357522
5 - 8 tpi	6°	3357516
6 - 10 tpi	0°	3357521
10 - 14 tpi	0°	3357520
Saw band set HSS bi-metal M 42		3357500
1 pc. saw band 6 - 10 tpi; 0°		
1 pc. saw band 5 - 8 tpi; 0° 1 pc. saw band 5 - 8 tpi; 6°		

„General saw band information“ on page 216

The metal-cutting band saw for challenging sawing tasks. With manual gearing and 3 sawing speeds

Facts that impress in terms of quality, performance and price

- ▶ Low-noise running action
- ▶ Rugged cast design
- ▶ Saw band lowering via hydraulic cylinder continuously adjustable by throttle valve
- ▶ Microswitch for automatic limit position cut-off
- ▶ Easily legible scale for adjusting the angle
- ▶ Equipped as a factory standard with bi-metal saw blade
- ▶ Ball-bearing borne saw band guide
- ▶ Rugged machine chassis with large wheels and handy transport bar allows trouble-free relocation of the machine
- ▶ Saw band tensioning at front, adjustable via handwheel
- ▶ Adjustable material stop for batch work
- ▶ Fully equipped; the user can immediately start productive work after commissioning



Scope of supply

- > Material stop
- > Bi-metal saw band
- > Machine chassis

Model	S 181G
Article no.	3300182

Technical specifications	
Electrical connection	400 V / 3 Ph ~50 Hz
Motor output	750 W
Coolant pump motor	90 W
General instructions	
Lifting the saw head	manual
Feed	continuously variable
Saw band speed	45 / 67 / 77 m/min
Saw band dimensions	2 362 x 19 x 0.9 mm
Cutting angle	0° to 45°
Dimensions	
Length	1 200 mm
Width	
Without material stop	450 mm
With material stop	600 mm
Height	
Saw head bottom limit position	1 060 mm
Saw head top limit position	1 550 mm
Weight	130 kg



Three speeds
> Switchable via gearbox

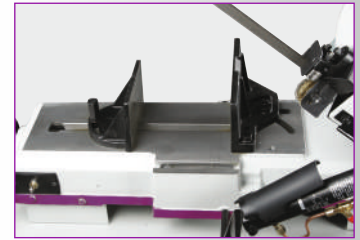

Quick clamping vice
> Clamping jaws adjustable from 0° to 45° for mitre cuts



Coolant equipment
> Integrated in chassis
> Tank capacity 11 litres

Cutting areas

			
0°	Ø 180 mm	180 mm	180 x 240 mm 65 x 300 mm
45°	Ø 110 mm	150 mm	110 x 170 mm

The cutting area was determined for a full section. The cutting range can be larger in case of cut-off sections.

AQUACUT C1	3530030
> For cooling the cut	
> 10 litres	

Saw bands HSS bi-metal M 42		
Teeth per inch	Tooth angle	Article no.
5 - 8 tpi	0°	3357522
5 - 8 tpi	6°	3357516
6 - 10 tpi	0°	3357521
10 - 14 tpi	0°	3357520
Saw band set HSS bi-metal M 42 1 pc. saw band 6 - 10 tpi; 0° 1 pc. saw band 5 - 8 tpi; 0° 1 pc. saw band 5 - 8 tpi; 6°		3357500

„General saw band information“ on page 216

Band saw for metal working with mitre-pivoting saw head and continuously adjustable saw band speed

Facts that impress in terms of quality, performance and price

- ▶ Low-noise running action
- ▶ Grey cast base plate and saw head
- ▶ Stable saw frame for smooth, low-vibration action
- ▶ Easily legible scale for adjusting the angle
- ▶ Equipped as a factory standard with bi-metal saw blade
- ▶ Saw band tensioning at front, adjustable via handwheel
- ▶ Adjustable material stop for batch work
- ▶ Fast workpiece clamping thanks to quick clamping vice
- ▶ Fully equipped; the user can immediately start productive work after commissioning

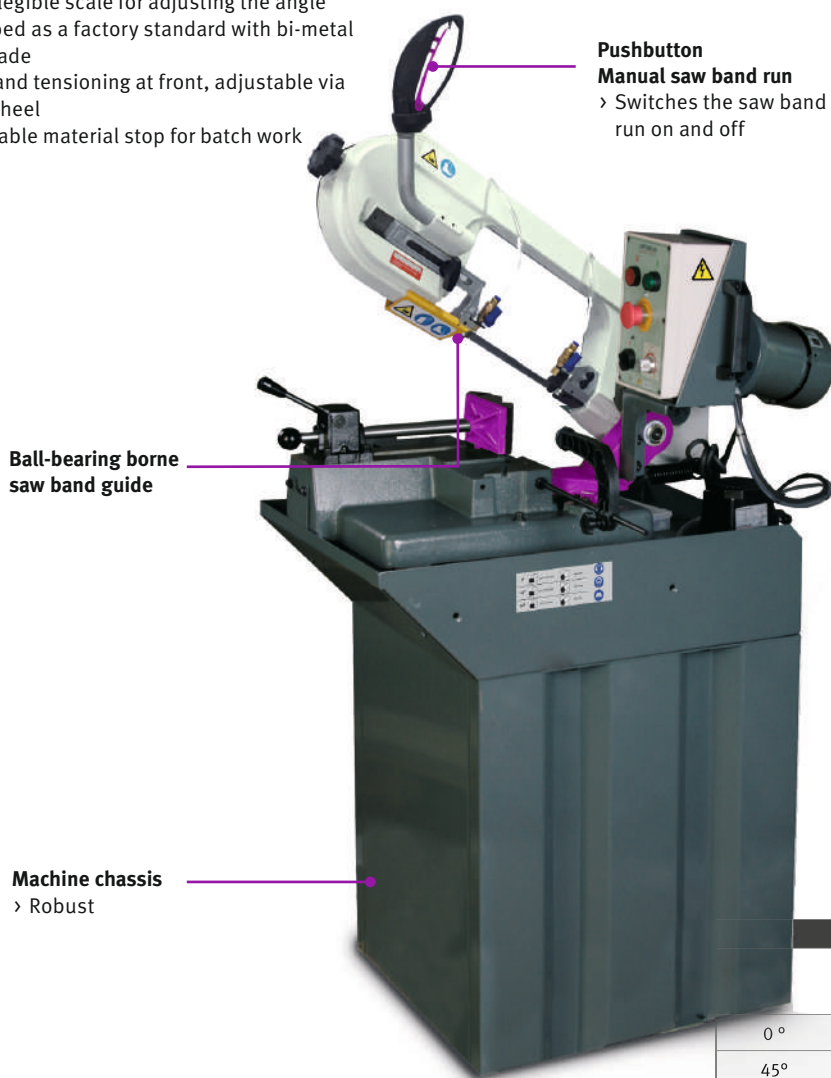

Control unit

- > Generously dimensioned
- > Emergency stop button
- > Coolant pump switch
- > Potentiometer





Vario drive

- > Continuously variable saw band speed

Scope of supply

- > Material stop
- > Bi-metal saw band
- > Machine chassis
- > Coolant system

Cutting areas

			
0°	Ø 150 mm	160 mm	150 x 160 mm
45°	Ø 105 mm	105 mm	105 x 130 mm
60°	Ø 65 mm	65 mm	65 x 65 mm

The cutting area was determined for a full section.
The cutting range can be larger in case of cut-off sections.

Model	S 150G Vario
Article no.	3300150
Technical specifications	
Electrical connection	230 V / 1 Ph ~ 50 Hz
Motor output	1.1 kW
Coolant pump motor	50 W
General instructions	
Lifting the saw head	manual
Feed	continuously variable
Saw band speed	20 - 65 m/min
Number of speeds	Continuously variable
Saw band dimensions	1 735 x 12.7 x 0.9 mm
Cutting angle	0° to 60°
Dimensions	
Length of vice open/closed	1 120 / 930 mm
Width without/with material stop	510 / 720 mm
Height of saw head bottom/top limit position	1 240 / 1 590 mm
Weight	100 kg

AQUACUT C1 3530030

- > For cooling the cut
- > 10 litres

Saw bands HSS bi-metal M 42

Teeth per inch	Tooth angle	Article no.
6 tpi	10°	3351521
6 - 10 tpi	0°	3351522
10 - 14 tpi	0°	3351538

Saw band set HSS bi-metal M 42		3351501
1 pc. saw band 6 tpi; 10°		
1 pc. saw band 6 - 10 tpi; 0°		
1 pc. saw band 10 - 14 tpi; 0°		

„General saw band information“ on page 216

Metal-cutting band saw ideal for light sawing work. Mitre cutting from -45° to 60° via pivoting saw head



Facts that impress in terms of quality, performance and price

- ▶ Circuit breaker for belt cover and saw band cover, low-voltage version
- ▶ Separate emergency stop button
- ▶ Low-voltage electronics 24 V
- ▶ Low-noise running action
- ▶ Mobile machine chassis
- ▶ Ball-bearing borne saw band guide
- ▶ Three gears for a wide choice of materials
- ▶ Microswitch for automatic limit position cut-off
- ▶ Easily legible scale for adjusting the angle
- ▶ Equipped as a factory standard with bi-metal saw blade
- ▶ Saw band tensioning at front, adjustable via handwheel
- ▶ Adjustable material stop for batch work
- ▶ Quick clamping vice for fast workpiece clamping

Saw head

- Grey cast iron
- › Both sides swivel from -45° to +60°



Fig.: S 131GH

Dimensions

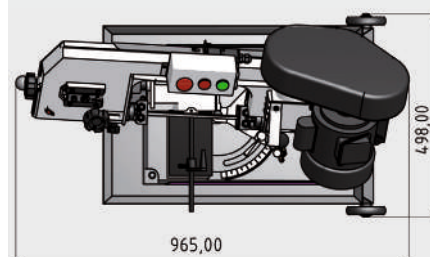
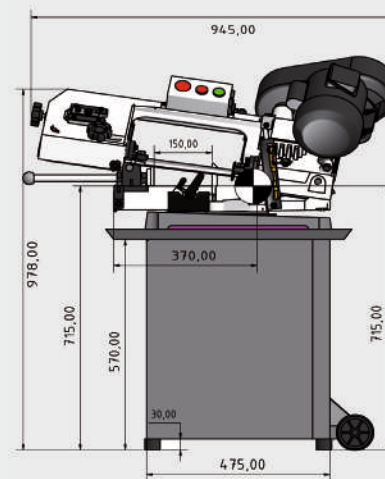

Scope of supply

- › Material stop
- › Bi-metal saw band
- › Machine chassis

Cutting areas

		
0°	Ø 128 mm	145 mm
45°	Ø 90 mm	100 mm
60°	Ø 45 mm	45 mm
-45°	Ø 90 mm	100 mm

The cutting area was determined for a full section.
The cutting range can be larger in case of cut-off sections.

Model	S 131GH
Article no.	3300131
Technical specifications	
Electrical connection	230 V / 1 Ph ~50 Hz
Motor output	1.1 kW
General instructions	
Lifting the saw head	manual
Feed	continuously variable
Saw band speed	22 / 31 / 55 m/min
Saw band dimensions	1 638 x 13 x 0.65 mm
Cutting angle	-45° to 60°
Weight	78 kg

Saw bands HSS bi-metal M 42

Teeth per inch	Tooth angle	Article no.
6 - 10 tpi	0°	3351512
8 - 12 tpi	0°	3351517
10 - 14 tpi	0°	3351518
6 tpi	10°	3351511
Saw band set HSS bi-metal M 42		3351500
1 pcs. Saw band 10 - 14 tpi; 0°		
1 pc. Saw band 6 tpi; 0°		
1 pc. Saw band 6 - 10 tpi; 6°		

„General saw band information“ on page 216

Light and handy metal band saw. Ideal for universal deployment on construction sites, on jobs, in customer service vehicles, workshops, hobby workshops and in agriculture



Facts that impress in terms of quality, performance and price

- ▶ Quick clamping vice for fast workpiece clamping
- ▶ Saw head swivels from 0° to 45° to allow angled sawing
- ▶ Easily legible scale for adjusting the angle
- ▶ Microswitch for automatic limit position cut-off
- ▶ Automatic lowering of the saw head via three-stage adjustable saw head lowering pressure
- ▶ Equipped as a factory standard with bi-metal saw blade
- ▶ Large, handy handle and light weight allow for trouble-free transport to the construction site
- ▶ Adjustable material stop for batch work
- ▶ Fully equipped; the user can immediately start productive work after commissioning
- ▶ Transportation lock



Automatic limit switch cut-off
 › Switches the saw band off at the bottom stop



Saw band guide
 › Ball-bearing borne 3-point guide



Transport
 › Large, handy handle and light weight allow for trouble-free transport to the construction site



Fig.: S 100 G



**Optional accessory
 Machine chassis MUG 1**

- › Stable, space-saving, folding, easy to transport
 - › Dimensions L x W x H: 500 x 470 x 780 mm
- Art. no. 3630000**

Scope of supply

- › Material stop
- › Operating tool
- › Bi-metal saw band

Cutting areas

			
0°	Ø 100 mm	100 mm	100 x 150 mm
45°	Ø 65 mm	60 mm	60 x 100 mm

The cutting area was determined for a full section.
 The cutting range can be larger in case of cut-off sections.

Saw bands HSS bi-metal M 42

Teeth per inch	Tooth angle	Article no.
10 - 14 tpi	0°	3351110
6 tpi	10°	3351109
Saw band set HSS bi-metal M 42 1 pcs. Saw band 10 - 14 tpi; 0° 2 pcs. Saw band 6 tpi; 10°		3351100

„General saw band information“ on page 216

Model	S 100G
Article no.	3300100
Technical specifications	
Electrical connection	230 V / 1 Ph ~ 50 Hz
Motor output	370 W
General instructions	
Saw band speed	45 m/min
Saw band dimensions	1 470 x 13 x 0.65 mm
Cutting angle	0° to 45°
Dimensions	
Length of vice open / closed	950 / 850 mm
Width without/with material stop	300 / 660 mm
Height bottom/top limit position	680 / 820 mm
Weight	23 kg

Transportable mitre bandsaws with excellent cutting precision, extremely low-noise. With continuously adjustable saw band speed

Facts that impress in terms of quality, performance and price

- ▶ Equipped as a factory standard with bi-metal saw blade
- ▶ Adjustable material stop for batch work
- ▶ Pushbutton for saw band run switches the saw band run on and off
- ▶ Base plate with anti-slip feet
- ▶ Low vibration and wear thanks to special gearbox with two hardened steel gears
- ▶ Vario drive motor with low speed and carbon brushes for up to 10x longer service life

SP 11V

- ▶ Saw head swivels from 0° to +45° to allow angled sawing

SP 13V

- ▶ Saw head swivels from 0° to +60° to allow angled sawing



Fig.: SP13V

optional accessory

Machine chassis MUG 1
Stable, space-saving, folding, easy to transport
› Dimensions L x W x H: 500 x 470 x 780 mm
Art. no. 3630000



Mitre square

- › Easily legible scale for adjusting the angle



Saw band guide

- › Ball-bearing borne; for an excellent band run and thus optimal cutting



Vario drive

- › Continuously adjustable saw band speed from 30 - 80 m/min.

Scope of supply

- › Material stop
- › Bi-metal saw band

Cutting areas				
SP 11V	0°	Ø 105 mm	100 mm	100 x 100 mm
SP 13V		Ø 125 mm	125 mm	125 x 125 mm
SP 11V	45°	Ø 65 mm	60 mm	60 x 65 mm
SP 13V		Ø 85 mm	85 mm	85 x 85 mm
SP 13V	60°	Ø 45 mm	45 mm	45 x 50 mm

The cutting area was determined for a full section. The cutting range can be larger in case of cut-off sections.

Saw bands HSS bi-metal M 42

	Teeth per inch	Tooth angle	Article no.
SP 11V	6 - 10 tpi	0°	3351542
	10 - 14 tpi	0°	3351543
SP 13V	6 - 10 tpi	0°	3351546
	10 - 14 tpi	0°	3351547

„General saw band information“ on page 216

Model	SP 11V	SP 13V
Article no.	3300070	3300075
Technical specifications		
Electrical connection	230 V / 1 Ph ~50 Hz	230 V / 1 Ph ~50 Hz
Motor output	850 W	1 kW
General instructions		
Saw band speed	30 - 80 m/min	30 - 80 m/min
Saw band dimensions	1 335 x 13 x 0.65 mm	1 440 x 13 x 0.65 mm
Cutting angle	0° - 45°	0° - 60°
Dimensions		
Length	650 mm	720 mm
Width without/with material stop	290 / 670 mm	300 / 650 mm
Height bottom/top limit position	450 / 630 mm	420 / 680 mm
Weight	19 kg	19.5 kg

Important information on „Operation of machines with frequency converters“ on page 249
The metal-cutting bandsaw (frequency converter) complies with the DIN EN 55011 standard: class C2

Height-adjustable MSR material stand as a manual aid for supporting and moving workpieces on metal-cutting saws. H version variably adjustable up to 1 050 mm

Facts that impress in terms of quality, performance and price

- ▶ Trouble-free and material transport when feeding and unloading workpieces
- ▶ Universally deployable for metal-cutting band saws, circular saws, etc.
- ▶ Roller support, continuously adjustable
- ▶ Safe workpiece support due to solid steel rollers with high load-bearing capacity
- ▶ Infinitely extensible
- ▶ Extension options for LMS length measuring systems
- ▶ Stable frame design with strong custom profile
- ▶ Steel bearing rollers, ball-bearing borne on both sides



Accessories PVC rollers

- › Additionally attachable
- › Made of non-slip PVC
- › To avoid scratches
- › Simply slot the rollers into the holder provided
- › With practical wall-mount

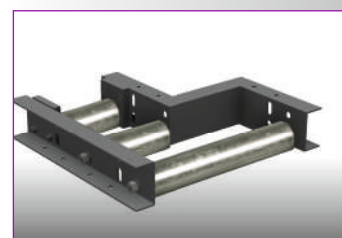

Table extension MSR 1

- › Additionally attachable
- › Can be fitted in both directions



Connecting plate

- › Additionally attachable
- › With add-on parts right and left
- › Slots

Model	MSR 4	MSR 7	MSR 10
Article no.	3357610	3357611	3357613
Model	MSR 4H	MSR 7H	MSR 10H
Article no.	3357001	3357002	3357003

Technical specifications			
Idler roller diameter	60 mm	60 mm	60 mm
Idler roller width	360 mm	360 mm	360 mm
Static table load	500 kg	700 kg	700 kg
Dimensions			
Length x width	1 000 x 440 mm	2 000 x 440 mm	3 000 x 440 mm
height	650 - 950 mm	650 - 950 mm	650 - 950 mm
Height H version	660 - 1 050 mm	660 - 1 050 mm	660 - 1 050 mm
Weight	30/33 kg	58/61 kg	78/83 kg

Scope of supply

- › Fastening material for extension

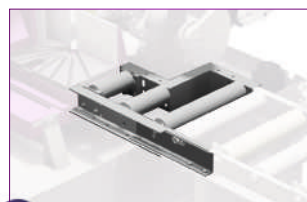

NEW

Accessories	PVC rollers 3 pcs.	Table extension MSR 1	Connecting plate
Article no.	3357609	3357006	3357005

Digital trimming and length measuring systems for attaching to MSR material stand.

For perfect length measurement and precise positioning

Facts that impress in terms of quality, performance and price

- ▶ Magnetic measuring system with magnetic strip
- ▶ For recurring measuring tasks with high precision 0.05 mm
- ▶ Automatic display switch-on
- ▶ Material stop for small pieces with extension
- ▶ Positioning slide right- and left-hand, folds up
- ▶ In case of longer breaks, the measuring system switches off and keeps the last stored dimension
- ▶ Measuring precision: $\pm(0.025 + 0.02 \times \text{measuring length [m]})$
- ▶ Battery life of up to 10 years



- › Display: LCD
- › Switching functions:
- › Display reset
- › Reset
- › Directional display \pm
- › Absolute dimension and chain dimension function
- › Right and left stop



Slide

- › Easily movable
- › Precisely guided
- › Replaceable, long-life dry plain bearings
- › Easy self-assembly

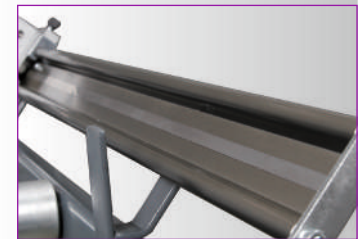

Linear guide

- › Lubrication-free
- › Very quiet action
- › Wear resistant
- › Corrosion-resistant
- › Low friction values
- › High static load bearing capacity



Fig.: MSR 4 material stand with LMS 10 length measuring system

Model	LMS 10	LMS 20	LMS 30	LMS 40
Article no.	3383851	3383852	3383853	3383854
Technical specifications				
Rail length	1 000 mm	2 000 mm	3 000 mm	4 000 mm
Travel	830 mm	1 830 mm	2 830 mm	3 830 mm

Other lengths on request

General saw band information

Workpiece

The workpiece to be machined must be firmly clamped so that it cannot vibrate or twist. Do not use damaged, bent or severely deformed workpieces. The closer the band saw guides are fixed relative to the workpiece, the more precise the cut becomes.



Teeth per inch

This figure describes the number of teeth per inch (25.4 mm).

As a general rule:

The shorter the cut length (e.g., sections), the finer the tpi you need to select. The greater the material attack (e.g., solid material), the coarser the tpi value used.

Too large a tpi value can cause the cut to run out as chips clog the gullet thus forcing the saw band out of its cutting line. Too small a tpi value can cause teeth to break out as the cutting pressure on the individual tooth becomes too great. At least 3 teeth need to be engaged to achieve economical results.

Running in saw bands

- ▶ Correct running in guarantees a long service life.
- ▶ Sharp cutting edges with extremely small edge radii are the precondition for high cutting capacity of the saw bands.
- ▶ To achieve an optimal service life, we recommend running in the saw band appropriately.
- ▶ Depending on the material and the dimension of the material you are cutting, determine the correct cutting speed (m/min.) and feed rate (mm/min.).
- ▶ The important thing is that the new saw band should be deployed at approx. 50 % of the determined feed rate only. The idea is to avoid the extremely sharp cutting edges on the teeth being damaged by micro fracturing in case of large chip thicknesses.
- ▶ New saw bands can tend to vibrate and cause vibration noise initially. If this happens, reduce the cutting speed slightly. In case of small workpiece dimensions, the run-in should be over approx. 300 - 500 cm² of the material you are cutting.
- ▶ If you are processing large workpiece dimensions, we recommend running in for a period of approx. 15 min. After running in, gradually increase the feed rate to the target value determined previously.

Optimal chip formation

- › Chips are the best indicator of a correctly adjusted feed and the correct saw band speed. Take a look at the chips you generate and set the feed correctly.

Thin chips that look like powder

- › Increase the feed rate or reduce the saw band speed.



Burnt, heavy chips

- › Reduce the feed rate and/or the saw band speed



Crinkly, silver and warm chips

- › Optimal feed rate and sawing speed



Materials	Cutting speed (M42)
Construction steel/Machining steel	80 - 90 m/min
Case-hardened steels/Heat-treated steels	45 - 75 m/min
Unalloyed tool steels/Rolled steels	40 - 60 m/min
Alloyed tool steels/high-speed steels	30 - 40 m/min
Stainless steels	20 - 35 m/min
Heat resistant steels/Highly heat-resistant alloys	15 - 25 m/min

Teeth per inch when using HSS bi-metal bands

Standard tpi		Combined tpi		Sawing tubes and sections						
Section cross-section	Number of teeth per inch	Section cross-section	Number of teeth per inch	diameter	Ø 40	Ø 80	Ø 100	Ø 150	Ø 200	Ø 300
				Wall thickness	Teeth per inch					
< 12 mm	14 tpi	< 25 mm	10 - 14 tpi	3 mm	8 - 12	8 - 12	8 - 12	8 - 12	6 - 10	6 - 10
12 - 30 mm	10 tpi	20 - 40 mm	8 - 12 tpi	8 mm	8 - 12	6 - 10	6 - 10	5 - 8	4 - 6	4 - 6
30 - 50 mm	8 tpi	25 - 70 mm	6 - 10 tpi	12 mm	6 - 10	5 - 8	5 - 8	4 - 6	4 - 6	4 - 6
50 - 80 mm	6 tpi	35 - 90 mm	5 - 8 tpi	15 mm	5 - 8	4 - 6	4 - 6	4 - 6	3 - 4	3 - 4
80 - 100 mm	4 tpi	50 - 100 mm	4 - 6 tpi	20 mm	-	4 - 6	4 - 6	4 - 5	4 - 5	4 - 5

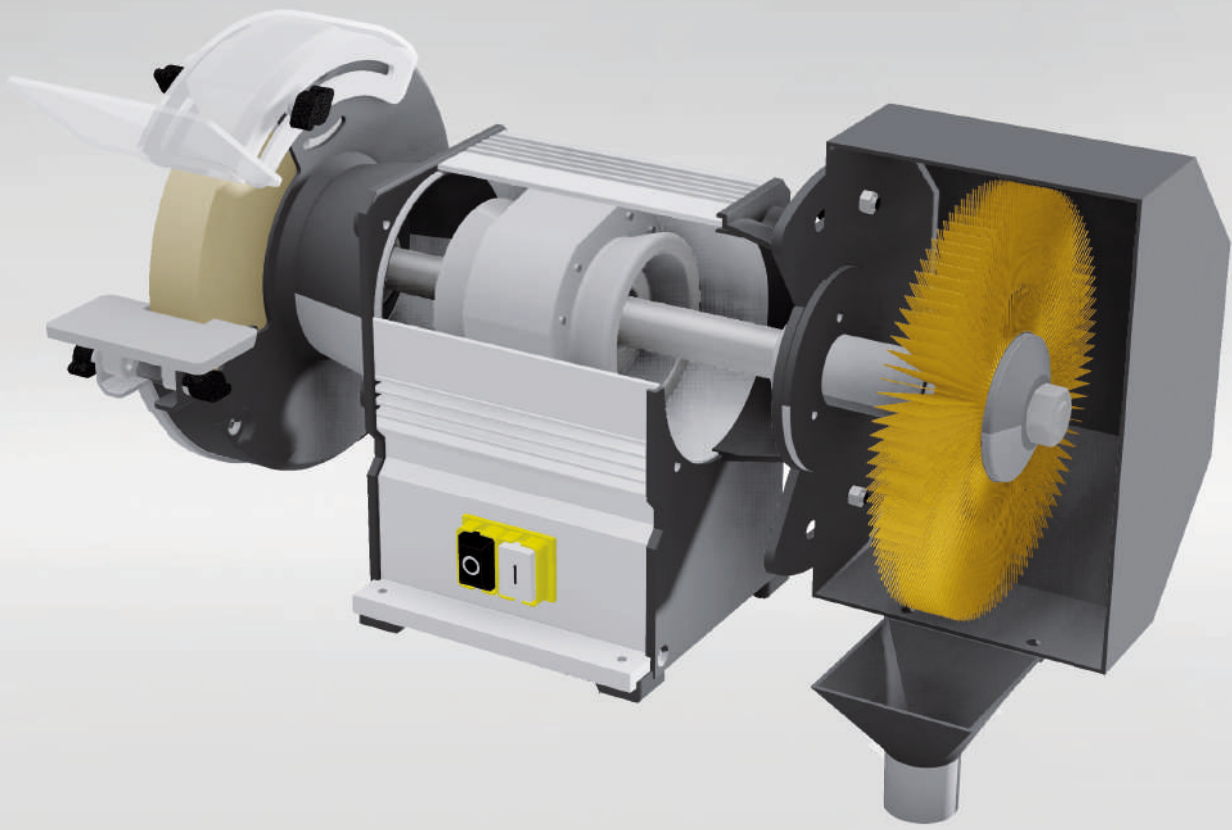

GRINDING AND POLISHING MACHINES

Versatile graver and tool grinding machine for various tool geometries

Facts that impress in terms of quality, performance and price

- ▶ Universally deployable thanks to versatile pivoting and adjustment options
- ▶ Many pivoting and adjustment options for creating gravers (cylindrical, centric, tapered)
- ▶ For grinding stamps, twist drills, electrodes, lathe tools, centres, etc.
- ▶ High level of precision thanks to rugged machine body and vibration-free driven precision grinding spindle
- ▶ Easy handling and operation
- ▶ Indexing head with 24 latching positions
- ▶ Adjustable dressing device



YouTube

Follow this for the video presentation of our drill bit grinding machine GH 20T
Subscribe to our YouTube channel, to avoid missing any of the new videos:
www.youtube.com/user/OptimumMaschinen

Model	GH20T
Article no.	3100125
Technical data	
Electrical connection	400 V/3 Ph ~50Hz
Motor output	370 W
Speeds	
Grinding disc speed, diamond	5 000 rpm
Grinding speed	max. 35 m/s
Motor speed	2 750 rpm
Travel	
Tool holder travel	140 mm
Tool holder fine adjustment	18 mm
Longitudinal fine adjustment	6 mm
Adjustable angle	
vertical/rear side	0° - 40°
horizontal/conical grinding	0° - 180°
Negative angles	0° - 52°
Latching setting angle of rotation	22* x 15° 180°
Collet chuck holder	
Clamping range	Ø 1- 12 mm
Clamping jaw type	385E (5C), DIN 6341
Dimensions	
Length x width x height	350 x 450 x 340 mm
Weight	45 kg

* Two latching positions occupied for sharpening drill bits

Replacement grinding disc	Grain size	Applications	Article no.
Corundum	K 80	Fast-working steel (HSS)	3100128
Diamond	K 150	Carbide	3100129

Comprehensive scope of delivery



- › Spring collets 385E (5C) DIN 6341
Ø 37.5 mm; L=89 mm; 20°
- › Sizes Ø 4/6/8/10/12 mm



- › Corundum cup grinding disc
Ø 100 x 51 x Ø 20 mm
- › Diamond cup grinding disc
Ø 100 x 51 x Ø 20 mm
(pre-assembled in as-delivered condition)

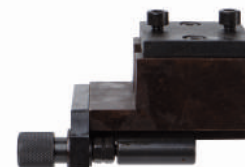

- › Device for sharpening lathe tools



- › Device for sharpening end mills



- › Device for sharpening twist drill bits



- › Operating tool



Fig.: Corundum

Fig.: Diamond

The handy drill bit grinding device - ideal for grinding twist drill bits

Facts that impress in terms of quality, performance and price

- ▶ Easy to operate for precise and inexpensive grinding of twist drill bits with two cutting edges
- ▶ Drill bit grinding without prior experience - clean, fast and precise
- ▶ Easy to transport
- ▶ Diamond grinding stone with long service life for the perfect grind
- ▶ Fully equipped with ER spring collets in the machine interior



Fig.: GH10T

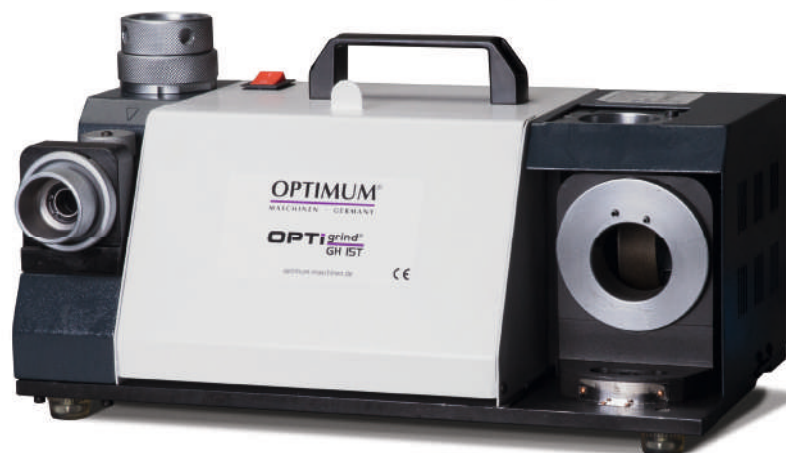

Follow this for the video presentation of our drill bit grinding machine GH 15T
Subscribe to our YouTube channel, to avoid missing any of the new videos:
www.youtube.com/user/OptimumMaschinen

Model	GH10T	GH 15T
Article no.	3100110	3100115
Technical specifications		
Electrical connection	230 V/1 Ph ~50 Hz	230 V/1 Ph ~50 Hz
Motor output	180 W	450 W
Technical specifications		
Grinding wheel	Steel disc, coated with Cubic crystallineboron nitride	
Collet chuck holder	ER20 DIN 6499	ER20 / ER 40 DIN 6499
Speed (continuously variable)	5 300 rpm	5 000 rpm
Tip sharpening angle	900 - 1350	900 - 1450
Grinding capacity drill bits	Ø 3 mm to Ø 13 mm	Ø 3 mm to Ø 30 mm
Dimensions		
Length x width x height	310 x 180 x 190 mm	450 x 240 x 270 mm
Weight	9.5 kg	33 kg

Drill bit ...

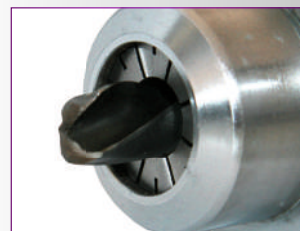

> ... with blunt cutting edges



> ... ground and tip sharpened

Comprehensive scope of delivery with complete assortment of spring collets



GH10T

- > 11 pcs. spring collets ER 20 sizes Ø 2 to Ø 13 mm



GH 15T

- > 6 pcs. spring collets ER 20 sizes Ø 3 to Ø 8 mm
- > 22 pcs. spring collets ER 40 sizes Ø 8 to Ø 30 mm

Accessories	Article no.
for GH10T	
Replacement grinding disc Crystalline cubic boron nitride Grain size: 170 - 200 Applications: High-speed steel (HSS)	3100126
Replacement grinding disc Diamond Grain size: 150 Applications: carbides	3100131
for GH15T	
Replacement grinding disc Crystalline cubic boron nitride Grain size: 170 - 200 Applications: High-speed steel (HSS)	3100127
Replacement grinding disc Diamond Grain size: 150 Applications: carbides	3100132

Drill bit grinding device with continuous speed control and precise repetition accuracy

Facts that impress in terms of quality, performance and price

- ▶ Solid cast baseplate with high deadweight for low-vibration action
- ▶ Long service life and quiet action thanks to balanced rotor with quality ball bearings
- ▶ Precise repetition accuracy thanks to prism-guided feed
- ▶ Variable speed control option for different materials
- ▶ Angle adjustment possible for all twist drill types
- ▶ Prism holders for precise centring of the workpiece
- ▶ Rubber cap for protection against dust and water
- ▶ Coolant tray and grinding cup included as standard in scope of delivery

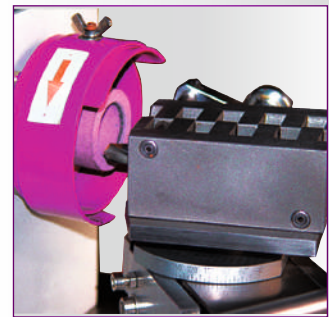

Large grinding area

Twist drills from Ø 3 to Ø 20 mm

Grinding cup

- › Self dressing
- › No dressing required

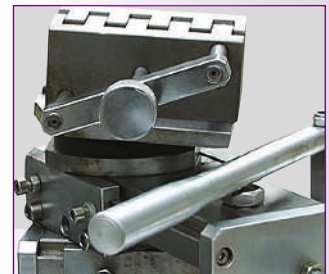

Prism support

- › Sturdy
- › Precise centring and secure hold

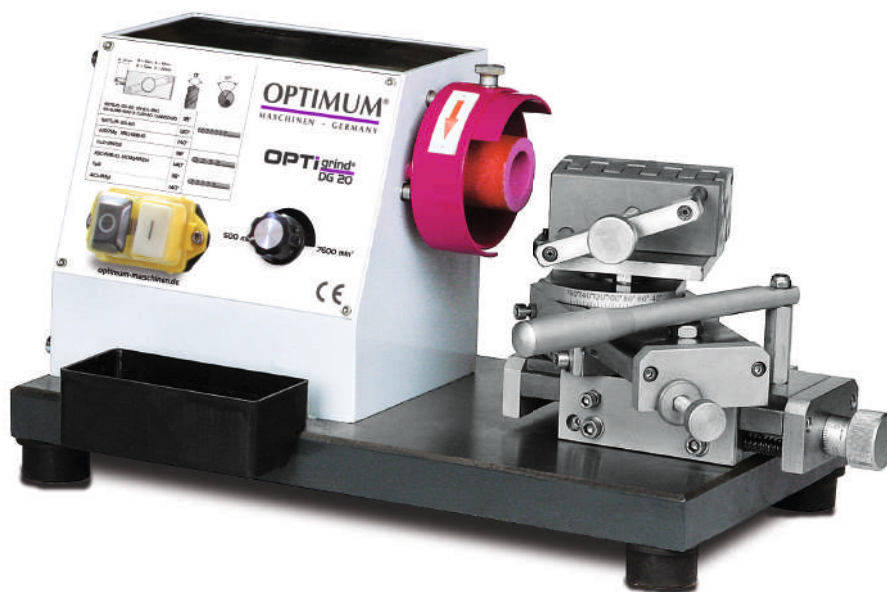

Scope of supply

- › Coolant tray
- › Cup grinding disc, red

Model	DG 20
Article no.	3100020
Technical specifications	
Electrical connection	230 V/1 Ph ~50 Hz
Motor output	600 W
Technical specifications	
Speed (continuously variable)	1 400 - 7 600 rpm
Grinding speed	16 m/s
Grinding capacity drill bits	Ø 3 mm to Ø 20 mm
Tip sharpening angle	90° - 150°
Cup grinding disc	
External Ø	40 mm
Inner Ø	26 mm
Thread Ø	M10
Depth	22 mm
Dimensions	
Length x width x height	490 x 270 x 235 mm
Weight	22.5 kg

Dimensions

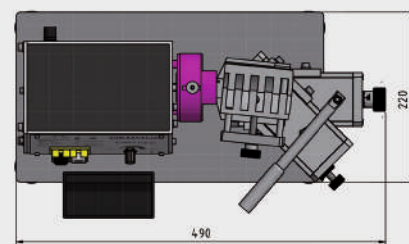
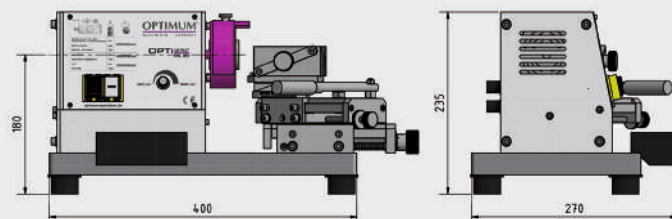

Accessories

Accessories	Article no.
Cup grinding disc	3107120
Cup grinding disc, green for carbides	3107121

The handy drill bit grinding device by quantum.

For easy sharpening of twist drill bits from Ø 3 mm to Ø 13 mm

Facts that impress in terms of quality, performance and price

- ▶ Easy to operate for inexpensive grinding of twist drill bits with two cutting edges
- ▶ Drill bit grinding without prior experience - clean, fast and precise
- ▶ Easy to transport
- ▶ Easy replacement of the grinding disc
- ▶ Positively-driven sharpening action, thus easy to operate
- ▶ Automatic grinding of the tip geometry thanks to cam
- ▶ Robust plastic housing with anti-slip base
- ▶ Diamond grinding stone with long service life for the perfect grind



Fig.: GQ-D13

Three steps to a ground drill bit



Adjust the drill bit

› Twist drills are aligned in projection length and at the correct angle



Sharpening the drill bit

› Through slight rotation from stop to stop



Tipping the drill bit

› Again through slight rotation from stop to stop

Scope of supply

- › Diamond grinding disc
- › Collet chuck holder

Model	GQ-D13
Article no.	3140020
Technical data	
Electrical connection	230 V/1 Ph ~50 Hz
Motor output	80 W
Technical specifications	
Speed (continuously variable)	4 200 rpm
Grinding wheel	Ø 78 mm
Grinding capacity drill bits	Ø 3 mm to Ø 13 mm
Dimensions	
Length x width x height	220 x 200 x 160 mm
Weight	2.5 kg

Accessories	Article no.
Replacement grinding disc	3140021
Crystalline cubic boron nitride	
Grain size: 170 - 200	
Applications: High-speed steel (HSS)	

Preface

Drilling

Milling

Turning

Saws

Grinding

Polishing

Lamps

Measuring

PREMIUM Bench grinding machines

GZ - DD Models with chassis and integrated extraction system

Facts that impress in terms of quality, performance and price

► **10-year OPTIMUM guarantee***

- Heavy industrial grinding machine absorbs the vibrations (which are low anyway) thanks to its high deadweight
- Also suitable for strong thrust force on the grinding discs
- Maintenance-free, durable, induction motor with smooth action
- Cast iron housing
- Spark guard
- Sturdy, adjustable workpiece support
- Grinding discs not included in standard scope of delivery

GZ-DD models:

- Integrated extraction system with aluminium fan and self-cleaning impellers
- Dust bag made of self-extinguishing woven material
- Sturdy chassis with water tray



Fig.: GZ 25DD with optional grinding discs

PREMIUM

Chassis	Article no.
› Without extractor	
GZ 20D	3091120
› L x W x H: 400 x 370 x 760 mm	
› Weight 33 kg	
GZ 25D	3091122
› L x W x H: 460 x 430 x 760 mm	
› Weight 40 kg	
GZ 30D	3091124
› L x W x H: 460 x 430 x 760 mm	
› Weight 52 kg	

Grinding disc	Article no.
› Pure corundum grinding disc	
› Hardness M - grey	
› Made in Italy	
GRINDING DISC GZ 20D/DD	
› Max. speed 3 345 rpm	
K 36	3098121
K 60	3098123
K 80	3098125
GRINDING DISC GZ 25D/DD	
› Max. speed 2 675 rpm	
K 36	3098131
K 60	3098133
K 80	3098135
GRINDING DISC GZ 30D/DD	
› Max. speed 2 230 rpm	
K 36	3098141
K 60	3098143
K 80	3098145

ELECTRONIC BRAKE	Article no.
	3091099
› Controlled braking	
› Including factory assembly	



*"Warranty conditions" on page 249

Model	GZ 20D	GZ 25D	GZ 30D
Article no.	3091010	3091015	3091020
Model	GZ 20DD	GZ 25DD	GZ 30DD
Article no.	3091040	3091045	3091050
Technical data			
Electrical connection	400 V/3 Ph ~50 Hz	400 V/3 Ph ~50 Hz	400 V/3 Ph ~50 Hz
Motor output	750 W	1.1 kW	1.8 kW
Grinding discs			
Dimensions	Ø 200 x 25 mm, Drill hole Ø 20 mm	Ø 250 x 30 mm, Drill hole Ø 25 mm	Ø 300 x 35 mm, Drill hole Ø 30 mm
Speeds	2 800 rpm	1 400 rpm	1 400 rpm
Dimensions			
L x W x H GZ-Models	550 x 290 x 360 mm	670 x 340 x 410 mm	810 x 420 x 560 mm
L x W x H GZ-DD models	800 x 710 x 1 300 mm	800 x 710 x 1 300 mm	810 x 1 200 x 1 300 mm
Weight GZ models	25 kg	44.8 kg	64.5 kg
Weight GZ-DD models	63.7 kg	91 kg	124 kg

Double grinder by OPTIMUM - quality products for trades and industry.

Facts that impress in terms of quality, performance and price

- ▶ Heavy, durable industrial design with maintenance-free motor for continuous use
- ▶ GU housing made of strand cast aluminium
- ▶ Long service life and quiet action thanks to balanced rotor with quality ball bearings
- ▶ Spark guard on each grinding disc reduces flying sparks
- ▶ Viewing glass made of break-proof material
- ▶ Sturdy adjustable workpiece support
- ▶ Vibration-damping rubber feet
- ▶ Coarse and fine grinding disc (K36/K60) included in standard scope of delivery



Fig.: SM 300



Fig.: GU 15 - GU 25

Grinding disc	Article no.
> Normal corundum grinding disc > Rough grain 36	
Ø 150 x 20 Ø 16 mm	3107150
Ø 175 x 25 Ø 32 mm	3107180
Ø 200 x 30 Ø 32 mm	3107210
Ø 250 x 40 Ø 32 mm	3107250
Ø 300 x 50 Ø 75 mm	3107270

Grinding disc	Article no.
> Normal corundum grinding disc > Fine grain 80	
Ø 150 x 20 Ø 16 mm	3107155
Ø 175 x 25 Ø 32 mm	3107185
Ø 200 x 30 Ø 32 mm	3107215
Ø 250 x 40 Ø 32 mm	3107255
Ø 300 x 50 Ø 75 mm	3107275

Accessories

„Machine bases“ on page 230



Scope of supply

- > Grinding disc - normal corundum coarse 36 grain
- > Grinding disc - normal corundum fine 80 grain

Model	GU 15	GU 18	GU 20	GU 25	SM 300
Article no. (230 V)	3101505	3101510	3101515	-	-
Article no. (400 V)	-	-	3101520	3101525	3101303
Technical specifications					
Electrical connection	230 V/1 Ph ~50 Hz	230 V/1 Ph ~50 Hz	230 V / 400 V	400 V/3 Ph ~50 Hz	400 V/3 Ph ~50 Hz
Motor output	450 W	450 W	600 W	1.5 kW	2.2 kW
Grinding discs					
Dimensions	Ø 150 x 20 mm Drill hole Ø 16 mm	Ø 175 x 25 mm Drill hole Ø 32 mm	Ø 200 x 30 mm Drill hole Ø 32 mm	Ø 250 x 40 mm Drill hole Ø 32 mm	Ø 300 x 50 mm Drill hole Ø 75 mm
Speeds	2 850 rpm	2 850 rpm	2 850 rpm	2 850 rpm	1 450 rpm
Extraction duct nominal width	Ø 34 mm	Ø 34 mm	Ø 34 mm	Ø 34 mm	Ø 35 mm / Ø 45 mm
Dimensions					
Length x width x height	389 x 205 x 265 mm	389 x 235 x 280 mm	495 x 260 x 330 mm	471 x 320 x 365 mm	680 x 375 x 394 mm
Weight	11 kg	14 kg	19 kg	33 kg	50 kg

Vario drive with Siemens inverter drive for PREMIUM grinders.

OPTION 1

Vario drive includes:

- ▶ Chassis with coolant tray
- ▶ Dimensions L x W x H: 400 x 370 x 760 mm
- ▶ **With Siemens inverter**
- ▶ Without grinder. This must be ordered separately along with your order

▶ Siemens inverter 0.75 kW
<ul style="list-style-type: none"> › PREMIUM double grinder GZ 20D › PREMIUM combined grinding machine GZ 20C
▶ Siemens inverter 1.5 kW
<ul style="list-style-type: none"> › PREMIUM double grinder GZ 25D › PREMIUM combined grinding machine GZ 25C

Description GZ 20C and GZ 25C see page 222

Description GZ 20C and GZ 25C see page 222

OPTION 2

Vario drive:

Grinder with chassis is converted to Vario

- ▶ **With Siemens inverter**
- ▶ Without grinder. This must be ordered separately along with your order

▶ Siemens inverter 0.75 kW
<ul style="list-style-type: none"> › PREMIUM double grinder GZ 20DD › PREMIUM combined grinding machine GZ 20D/C
▶ Siemens inverter 1.5 kW
<ul style="list-style-type: none"> › PREMIUM double grinder GZ 25DD › PREMIUM combined grinding machine GZ 25D/C

Description GZ 20D/C and GZ 25D/C see page 222

Description GZ 20DD and GZ 25DD see page 222

Circumferential speeds

- › GZ 25 controllable from 19 m/s to 3 m/s
- › GZ 20 controllable from 30 m/s to 5 m/s



Fig. Vario drive option 1
Figure with optional grinder



Fig. Vario drive option 2
Chassis with extraction unit
Figure with optional grinder

Vario drive	OPTION 1 With chassis
Motor output up to 0.75 kW	3010330
Motor output up to 1.5 kW	3010332

Without grinder - must be ordered separately along with your order

Note Vario drive can only be ordered ex works. Cannot be retrofitted

Vario drive	OPTION 2
Motor output up to 0.75 kW	3010340
Motor output up to 1.5 kW	3010342

Without grinder - must be ordered separately along with your order

Vario drive with Siemens inverter drive Sinamics V20 with GU 1 chassis allows the grinder speed to be reduced by up to 84%

Facts that impress in terms of quality, performance and price

Vario drive with chassis GU 1:

- ▶ Cyclone vacuum integrated in chassis, consequently less space required
- ▶ Noise-insulated
- ▶ Lamp holder for LED 3-500
- ▶ Dimensions L x W x H: 477 (550) x 340 x 805 (890) mm
- ▶ **With Siemens inverter**
- ▶ **Automatic start-up**
 - › When the double grinder is switched on, the extractor automatically starts with a delay of 2-3 seconds. It is not necessary to additionally switch on extraction
 - › Extraction continues for 2-3 seconds after switching off the double grinder
 - › The residual dust is extracted after switching off the machine in line with the Hazardous Materials Ordinance



Fig. GU 1 chassis with optional accessories

Vario drive	
Motor output up to 0.75 kW	Motor output up to 1.5 kW
Circumferential speeds	
30 m/s to 5 m/s controllable	37 m/s to 6 m/s controllable
Art. no.: 3010320	Art. no.: 3010322
Without grinder - must be ordered separately along with your order.	

Required power grinders	
Siemens inverter 0.75 kW	Siemens inverter 1.5 kW
<ul style="list-style-type: none"> › Combined grinding machines GU 20B › Universal grinding machine GU 20S › Double grinder GU 20 › Polishing grinder GU 20P 	<ul style="list-style-type: none"> › Combined grinding machines GU 25B › Universal grinding machine GU 25S › Double grinder GU 25 › Polishing grinder GU 25P

The Vario conversion complies with the DIN EN 55011 standard: class C2

Double grinder Fig. without Vario conversion		
Model	GU 20	GU 25
Article no.	3101520	3101525

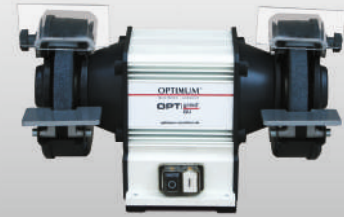

Description see page 223

Combined grinding machine Fig. without Vario conversion		
Model	GU 20B	GU 25B
Article no.	3101615	3101620

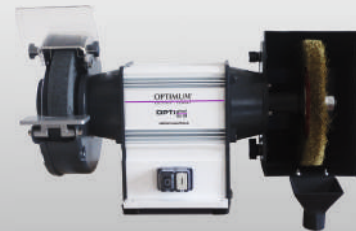

Description see page 228

Universal grinding machine Fig. without Vario conversion		
Model	GU 20S	GU 25S
Article no.	3101575	3101580

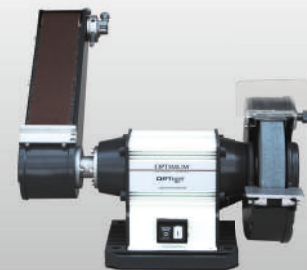

Description see page 229

Polishing machine Fig. without Vario conversion		
Model	GU 20P	GU 25P
Article no.	3101545	3101550



Description see page 227

Preface

Drilling

Milling

Turning

Saws

Grinding

Polishing

Lamps

Measuring

PREMIUM Combined grinding machines for workshops, steel construction companies,... GZ - CD Models with chassis and integrated extraction system



Facts that impress in terms of quality, performance and price

- ▶ **10-year OPTIMUM guarantee***
- ▶ Heavy industrial combined grinding machine absorbs the vibrations (which are low anyway) thanks to its high deadweight
- ▶ Also suitable for strong thrust force on the grinding disc and brush
- ▶ Maintenance-free, durable, induction motor with smooth action
- ▶ Cast iron housing
- ▶ Sturdy, adjustable workpiece support
- ▶ Grinding disc and brush not included in standard scope of delivery



Fig.: GZ 20C with optional grinding disc and brush



Fig.: Chassis and integrated extraction system

Multi-purpose wire brush
 › High tensile steel wire available as an accessory in various thicknesses

Brush protection housing
 › Swivelling
 › Extraction duct for attaching an extraction unit

Chassis	Article no.
› Without extractor	
GZ 20C	3091120
› L x W x H: 400 x 370 x 760 mm	
› Weight 33 kg	
GZ 25C	3091122
› L x W x H: 460 x 430 x 760 mm	
› Weight 40 kg	



Grinding disc	Article no.
› Pure corundum grinding disc	
› Hardness M - white	
› Made in EU	
GZ 20C/GZ 20CD	
K 36	3098121
K 60	3098123
K 80	3098125
GZ 25C/GZ 25CD	
K 36	3098131
K 60	3098133
K 80	3098135

Round brush	Article no.
› High tensile steel wire	
› Made in EU	
GZ 20C/GZ 20CD	
0.35 mm	3098081
0.5 mm	3098082
GZ 25C/GZ 25CD	
0.3 mm	3098086
0.5 mm	3098087

ELECTRONIC BRAKE	Article no.
	3091099

- › Controlled braking
- › Including factory assembly



*"Warranty conditions" on page 249

Model	GZ 20C	GZ 25C
Article no.	3091070	3091075
Model	GZ 20CD	GZ 25CD
Article no.	3091080	3091085

Technical data	GZ 20C	GZ 25C
Electrical connection	400 V/3 Ph ~50 Hz	400 V/3 Ph ~50 Hz
Motor output	750 W	1.1 kW
Grinding discs		
Dimensions	Ø 200 x 25 mm, bore Ø 20 mm	Ø 250 x 30 mm, bore Ø 25 mm
Speeds	2 800 rpm	1 400 rpm
Dimensions		
L x W x H GZ-Models	650 x 300 x 360 mm	850 x 340 x 410 mm
L x W x H GZ-CD models	900 x 710 x 1 300 mm	850 x 1 200 x 1 300 mm
Weight GZ-C models	26.5 kg	40.7 kg
Weight GZ-CD models	65 kg	87 kg

Polishing machines for surface machining of metal workpieces

Facts that impress in terms of quality, performance and price

- ▶ Heavy, durable industrial design with maintenance-free motor
- ▶ Housing made of strand cast aluminium
- ▶ Long service life and quiet action thanks to balanced rotor with quality ball bearings
- ▶ Vibration-damping rubber feet
- ▶ Two wide polishing discs included in standard scope of delivery



Fig.: GU 20P

Polishing disc	Article no.
> hard	
Ø 200 x 20 Ø 16 mm	3107321
Ø 250 x 25 Ø 20 mm	3107331



Polishing disc	Article no.
> soft	
Ø 200 x 20 Ø 16 mm	3107320
Ø 250 x 25 Ø 20 mm	3107330



Model	GU 20P	GU 25P
Article no. (230 V)	3101540	-
Article no. (400 V)	3101545	3101550
Technical data		
Electrical connection	230 V / 1 Ph or 400 V / 3 Ph	400 V/3 Ph ~50 Hz
Motor output	600 W	1.5 kW
Rotational speed	2 850 rpm	2 850 rpm
Polishing disc size	Ø 200 x 20 mm	Ø 250 x 25 mm
Dimensions L x W x H	545 x 200 x 262 mm	555 x 250 x 296 mm
Weight	10.6 kg	17.4 kg

Accessories

„Machine bases“ on page 230

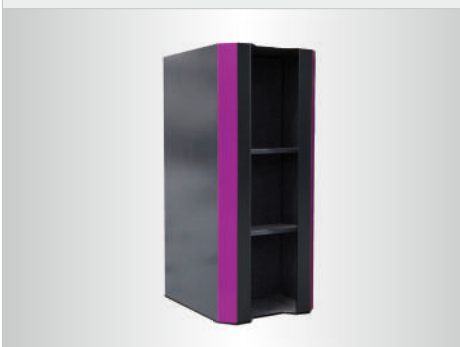

Combined grinding machines by Optimum for workshops

Facts that impress in terms of quality, performance and price

- ▶ Durable design with maintenance-free motor for continuous use
- ▶ Housing made of strand cast aluminium
- ▶ Large, heavy fastening flanges ensure excellent disc concentricity
- ▶ Grinding attachment with graphite support - prevents friction and heat
- ▶ Stop allows for fast and convenient initial grinding of the workpieces
- ▶ Swivelling brush protection housing
- ▶ Extraction duct for attaching an extraction unit



Multi-purpose wire brush
 ▶ High tensile steel wire

Grinding disc	Article no.
▶ Normal corundum grinding disc	
▶ Rough grain 36	
Ø 150 x 20 Ø 16 mm	3107150
Ø 175 x 25 Ø 32 mm	3107180
Ø 200 x 30 Ø 32 mm	3107210
Ø 250 x 40 Ø 32 mm	3107250

Grinding disc	Article no.
▶ Normal corundum grinding disc	
▶ Fine grain 80	
Ø 150 x 20 Ø 16 mm	3107155
Ø 175 x 25 Ø 32 mm	3107185
Ø 200 x 30 Ø 32 mm	3107215
Ø 250 x 40 Ø 32 mm	3107255

Multi-purpose wire brush	Article no.
▶ Thickness 0.3 mm	
Ø 150 x 20 Ø 16 mm	3107425
Ø 175 x 20 Ø 32 mm	3107430
Ø 200 x 20 Ø 32 mm	3107435
Ø 250 x 20 Ø 32 mm	3107440

Accessories for machine bases

„Machine bases“ on page 230

Scope of supply
▶ Grinding disc - normal corundum coarse 36 grain
▶ Multi-purpose wire brush, wire thickness 0.3 mm

Model	GU 15B	GU 18B	GU 20B	GU 25B
Article no. (230 V)	3101600	3101605	3101610	-
Article no. (400 V)	-	-	3101615	3101620
Technical specifications				
Electrical connection	230 V/1 Ph ~50 Hz	230 V/1 Ph ~50 Hz	230 V / 400 V	400 V/3 Ph ~50 Hz
Motor output	450 W	450 W	600 W	1.5 kW
Dimensions				
Grinding discs	Ø 150 x 20 mm Drill hole Ø 16 mm	Ø 175 x 25 mm Drill hole Ø 32 mm	Ø 200 x 30 mm Drill hole Ø 32 mm	Ø 250 x 40 mm Drill hole Ø 32 mm
Multi-purpose wire brush	Ø 150 x 20 mm Drill hole Ø 16 mm	Ø 175 x 20 mm Drill hole Ø 32 mm	Ø 200 x 20 mm Drill hole Ø 32 mm	Ø 250 x 20 mm Drill hole Ø 32 mm
Speeds	2 850 rpm	2 850 rpm	2 850 rpm	2 850 rpm
Dimensions				
Length x width x height	495 x 305 x 305 mm	495 x 305 x 305 mm	580 x 345 x 335 mm	650 x 380 x 385 mm
Weight	11 kg	13 kg	17 kg	30 kg

Functional universal grinding machines with grinding attachment

Facts that impress in terms of quality, performance and price

- ▶ Rugged and sturdy universal grinding machines with grinding belt and grinding disc for a variety of materials
- ▶ Heavy, durable industrial design with maintenance-free motor for continuous use
- ▶ Housing made of strand cast aluminium
- ▶ Large, heavy fastening flanges ensure excellent disc concentricity
- ▶ Grinding attachment with graphite support; prevents friction and heat
- ▶ Stop allows for fast and convenient initial grinding of the workpieces
- ▶ Belt run adjustment without tools - adjustable using a single star knob
- ▶ Universal corundum grinding disc and grinding belt included in standard scope of delivery

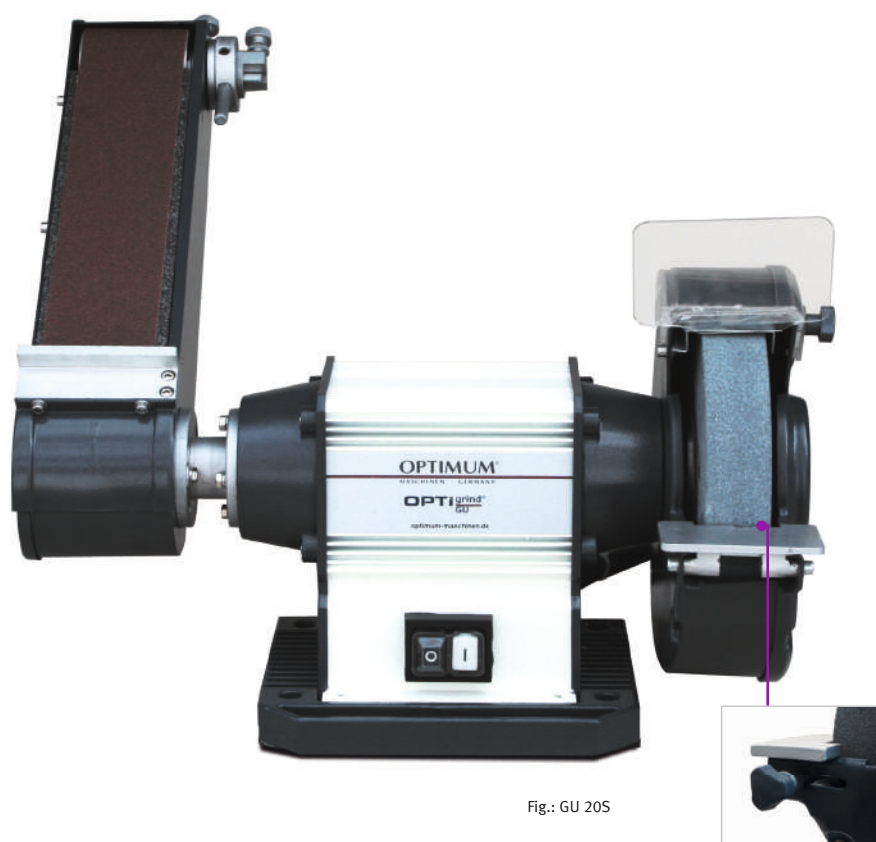

Fig.: GU 20S

- Workpiece support**
- ▶ Sturdy
 - ▶ Adjustable

Model	GU 20S	GU 25S
Article no. (230 V)	3101570	-
Article no. (400 V)	3101575	3101580
Technical specifications		
Electrical connection	230 V or 400V ~50 Hz	400 V/3 Ph ~50 Hz
Motor output	600 W	1.5 KW
Grinding discs		
Grinding disc size	Ø 200 x 30 mm Drill hole Ø 32 mm	Ø 250 x 40 mm Drill hole Ø 32 mm
Grinding attachment		
Grinding belt length, width	75 x 762 mm	75 x 1 016 mm
Grinding attachment swivel range	90°	90°
Extraction duct nominal width	Ø 32 mm	Ø 32 mm
Grinding support	87 x 180 mm	87 x 305 mm
Rotational speed	2 850 rpm	2 850 rpm
Dimensions L x W x H	501 x 261 x 459 mm	514 x 319 x 596 mm
Weight	20.7 kg	31.5 kg

Grinding disc	Article no.
▶ Normal corundum grinding disc	
▶ Rough grain 36	
Ø 200 x 30 Ø 32 mm	3107210
Ø 250 x 40 Ø 32 mm	3107250

Grinding disc	Article no.
▶ Normal corundum grinding disc	
▶ Fine grain 80	
Ø 200 x 30 Ø 32 mm	3107215
Ø 250 x 40 Ø 32 mm	3107255

Grinding belt	PQ	Article no.
▶ For GU 20S		
▶ Sanding belt size 75 x 762		
Grain size 40	5 pcs.	3357612
Grain size 40	5 pcs.	3357614
Grain size 80	5 pcs.	3357616
Grain size 120	5 pcs.	3357618
Grain size 180	5 pcs.	3357619
Grain size 240	5 pcs.	3357620

Grinding belt	PQ	Article no.
▶ For GU 25S		
▶ Sanding belt size 75 x 1 016		
Grain size 40	5 pcs.	3357682
Grain size 40	5 pcs.	3357684
Grain size 80	5 pcs.	3357686
Grain size 120	5 pcs.	3357688
Grain size 180	5 pcs.	3357689
Grain size 240	5 pcs.	3357690

Accessories for machine bases

„Machine bases“ on page 230



Scope of supply

- ▶ Grinding disc normal corundum fine 80 grain
- ▶ Grinding belt normal corundum fine 80 grain

GU 1 - Machine chassis with cyclone extractor for grinding machines

Facts that impress in terms of quality, performance and price

- ▶ Sturdy chassis
- ▶ Cyclone vacuum integrated in chassis, consequently less space required
- ▶ For GU and GU-S machines
- ▶ Noise-insulated
- ▶ Without drilled holes - must be drilled individually
- ▶ Y adapter for two-tube extraction unit connection, Ø 30 mm and Ø 35 mm



Lamp holder

- ▶ prepared for machine lamp LED 3-500

Model	GU 1	
Article no.	3107110	3107109
Elec. connection	230 V / 1 Ph	400 V / 3 Ph
Motor output	1.3 kW	
Rotational speed	29 000 rpm	
Air throughput	2.3 m ³ per minute	
Dimensions	477 (550) x 340 x 805 (890) mm	
Weight	44 kg	

Note: The extraction unit needs a neutral conductor, 400-V version



Fig. with optional grinder and extraction tubes

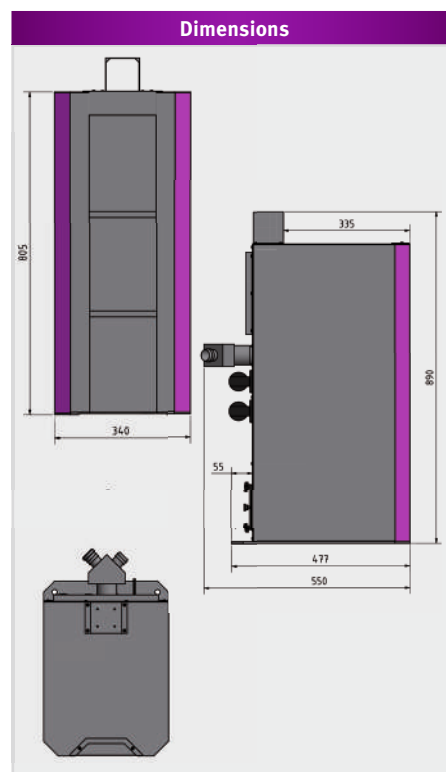

Extraction hose

3107111

- 2 flexible extraction hoses for GU and GU-S grinders



Automatic start-up GU 1 and GU 2

When the external device is switched on, the extraction unit automatically starts up after a delay of 2-3 seconds. No need to additionally switch the extraction unit on or off: the residual dust is extracted after switching off the machine in line with the Hazardous Materials Ordinance

GU 2 - Machine chassis with extraction unit for OPTIMUM machines such as the BSM or external machines

Facts that impress in terms of quality, performance and price

- ▶ Cyclone extraction unit with two motors
- ▶ Includes Y adapter for two-tube extraction unit connection, 60 x 300-1000 mm flexible
- ▶ Small footprint
- ▶ Noise-insulated
- ▶ External 230V continuous supply

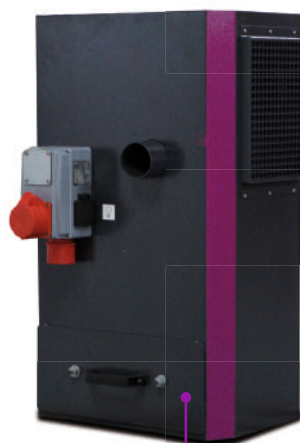

Chip drawer

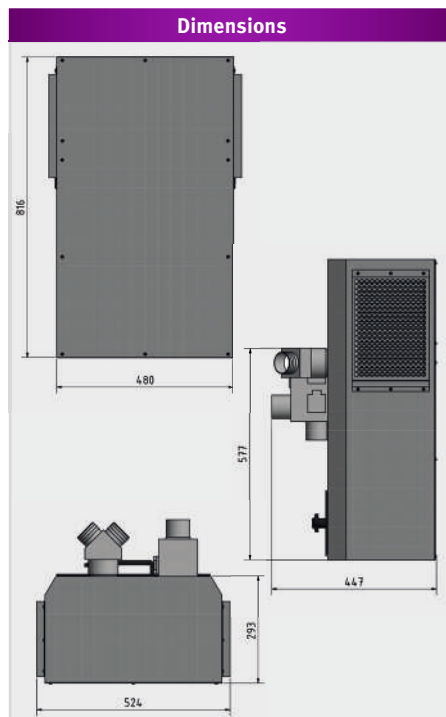

Extraction hose

3107116

- 2 pcs. flexible extraction tube Ø 60 mm
- Length 300 - 1000 mm

Model	GU 2	
Article no.	3107115	
Elec. connection	400 V / 3 Ph	
Total connected load	4 kW	
Motor output per blower	1.3 kW	
Number of blowers	2	
Rotational speed	29 000 rpm	
Air throughput	4.6 m ³ per minute	
Chip filter container volume	15 litres	
Dimensions L x W x H	525 x 440 x 815 mm	
Weight	60 kg	

The chassis GU 1 and GU 2 comply with the DIN EN 55011 standard: class C2.

Note: The extraction unit needs a neutral conductor

GU 3 - Machine chassis

Facts that impress in terms of quality, performance and price

- ▶ Coolant tray
- ▶ Small footprint
- ▶ Specially suited for our machines
 - › Bench grinders GU 15 - GU 25
 - › Universal grinding machines GU 20S and 25S
 - › Combined sander GU 15B - GU 25B
 - › Polishing machines GU 20P and GU 25P

Model	GU 3
Article no.	3107118
Dimensions	320 x 270 x 825 mm
Weight	14.5 kg

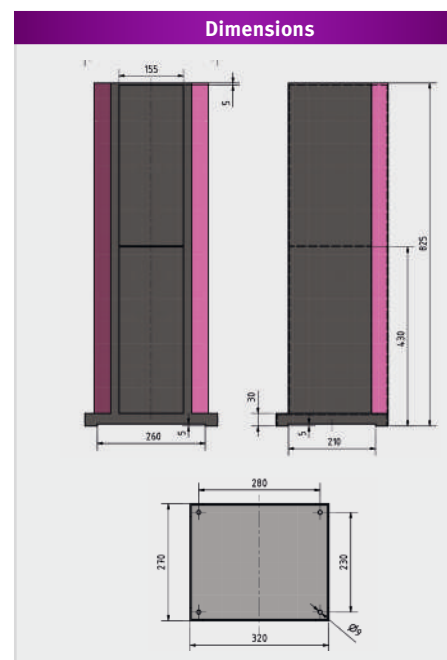

Machine chassis

Facts that impress in terms of quality, performance and price

- ▶ Closed chassis
- ▶ Solid design
- ▶ Specially suited for our machines
 - › Bench grinders SM 300

Model	Chassis
Article no.	3107103
Dimensions	505 x 600 x 790 mm
Weight	23 kg



Wall holder

Facts that impress in terms of quality, performance and price

- ▶ Coolant tray
- ▶ L x W x H: 332 x 300 x 230 mm
- ▶ Specially suited for our machines
 - › Bench grinders GU 15 - GU 25
 - › Universal grinding machines GU 20S and 25S
 - › Combined sander GU 15B - GU 25B
 - › Polishing machines GU 20P and GU 25P



Model	Wall holder
Article no.	3107050

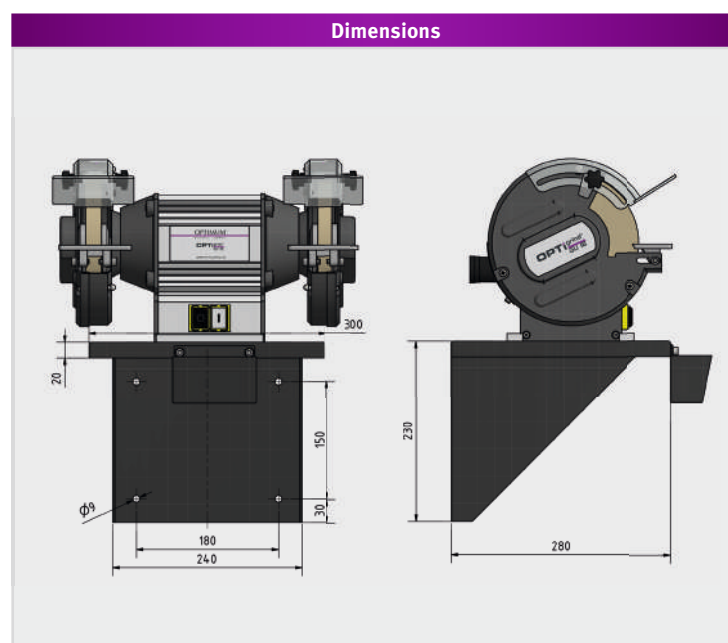

Heavy and rugged industrial design belt grinding machine for roughing, finishing and profile grinding of various materials in continuous operations

Facts that impress in terms of quality, performance and price

- ▶ Time-saving deburring of edges and weld polishing
- ▶ Sturdy and vibration-free design
- ▶ Powerful motor
- ▶ Grinding table pivots through 15° - 30°
- ▶ Continuously adjustable top stop supports fast and convenient initial grinding of workpieces
- ▶ Large flat grinding surface
- ▶ Adjustable stops for universal deployment
- ▶ Operating tools in practical holder
- ▶ Additional safety device
- ▶ Fast belt running speed of 33 m/sec. for fast material removal
- ▶ Extraction duct front and rear for attaching an extraction unit
- ▶ Spark guard
- ▶ Workpiece support with adjustable tilt angle allows grinding at the required angle
- ▶ One grinding belt included in standard scope of delivery



Flat grinding surface

- › Open throughout and to rear
- › Also perfectly suited for machining longer workpieces



Rollers

- › Rubberised
- › Quiet action
- › Prevents the belt slipping



Fig.: BSM 150



Workpiece support	Article no.
› Continuously adjustable; supports fast initial grinding	
For BSM 75	3357881
For BSM 150	3357891



Grinding belts BSM 75*	Article no.	PQ
Grain size 40	3357642	5 units
Grain size 40	3357644	5 units
Grain size 80	3357646	5 units
Grain size 120	3357648	5 units
Grain size 180	3357649	5 units
Grain size 240	3357650	5 units

Sanding belts BSM 150	Article no.	PQ
Grain size 40	3357672	5 units
Grain size 40	3357674	5 units
Grain size 80	3357676	5 units
Grain size 120	3357678	5 units
Grain size 180	3357679	5 units
Grain size 240	3357680	5 units



Scope of supply
› Grinding belt 60 grain
› Allen key

Model	BSM 75	BSM 150
Article no.	3321075	3321150
Technical data		
Electrical connection	400 V/3 Ph ~50 Hz	400 V/3 Ph ~50 Hz
Motor output	3 kW	4 kW
Speeds		
Rotational speed	3 000 rpm	3 000 rpm
Circumferential belt speed	33 m/sec.	33 m/sec.
Grinding belt		
Grinding belt dimensions	75 x 2 000 mm	150 x 2 000 mm
Dimensions		
Extraction duct nominal width inside	∅ 57 mm	∅ 57 mm
Extraction duct nominal width outside	∅ 60 mm	∅ 60 mm
Dimensions length x width	500 x 995 mm	575 x 995 mm
Height: Bottom pivot bearing	1 045 mm	1 045 mm
Height: Top pivot bearing	1 135 mm	1 135 mm
Weight	98 kg	125 kg

Universally deployable belt and disc grinding machine with swivelling grinding arm for deburring, surface and profile grinding

Facts that impress in terms of quality, performance and price

- ▶ Powerful motor
- ▶ Pneumatic sanding belt tension manually adjustable
- ▶ Easily replaceable grinding belt
- ▶ Fine adjustment for parallel belt run
- ▶ Pivoting grinding table, adjustable via clamping lever
- ▶ Extraction port
- ▶ Delivered with grinding sheet bonded onto grinding disc
- ▶ The hook and loop fastener pad and grinding discs available as accessories offer good adhesion and easy replacement

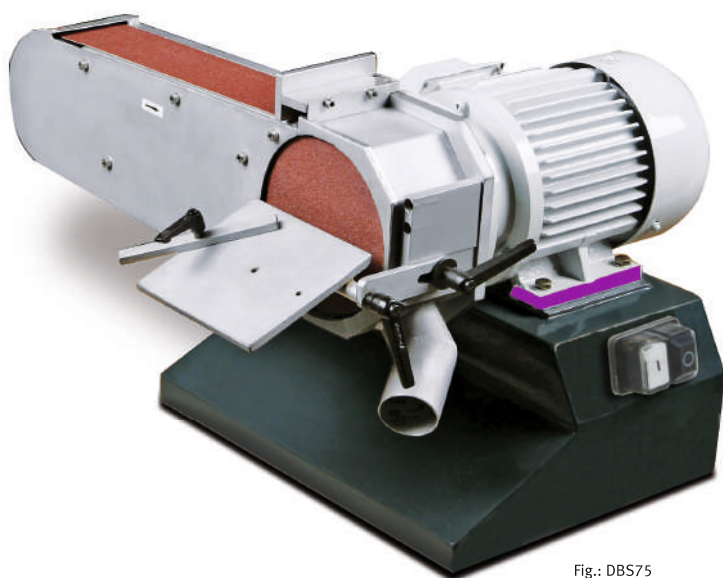

Fig.: DBS75

Scope of supply

- › Grinding belt 60 grain
- › Grinding sheet 60 grain

Model	DBS 75
Article no.	3311075
Technical specifications	
Electrical connection	400 V/3 Ph ~50 Hz
Motor output	1.1 kW
Rotational speed	1 410 rpm
Belt running speed	11 m/sec.
Dimensions	
Grinding belt dimensions	75 x 1 180 mm
Grinding disc dimensions	Ø 150 mm
Extraction duct nominal width inside	Ø 47 mm
Extraction duct nominal width outside	Ø 50 mm
Grinding support	85 x 215 mm
Swivel range belt grinding table	90°
Length x width x height	665 x 560 x 405 (765) mm
Weight	68 kg

Grinding belt	Article no.	PQ
› Size: 75 x 1 180 mm		
Grain size 40	3357622	5 units
Grain size 40	3357624	5 units
Grain size 80	3357626	5 units
Grain size 120	3357628	5 units
Grain size 180	3357629	5 units
Grain size 240	3357630	5 units

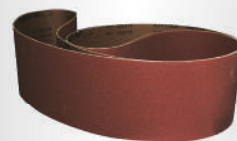

Grinding sheet	Article no.	PQ
› Size: Ø 150 mm		
Grain size 40	3357832	5 units
Grain size 40	3357834	5 units
Grain size 80	3357836	5 units
Grain size 120	3357838	5 units
Grain size 180	3357839	5 units
Grain size 240	3357840	5 units

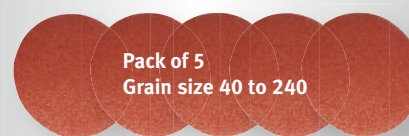

Hook and loop disc	3357802
› For the grinding disc. Good grinding disc adhesion, easy replacement	

Dimensions

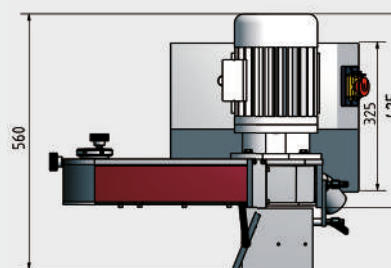
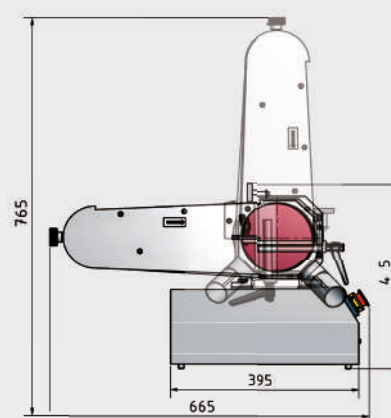

Disc grinder for machining metal surfaces

Facts that impress in terms of quality, performance and price

- ▶ Versatile areas of application:
- ▶ For roughing, fine and moulding grinding work
- ▶ Sturdy and stable machine body
- ▶ Balanced aluminium grinding disc for smooth action
- ▶ Powerful motor
- ▶ Delivered with grinding sheet bonded onto grinding disc



Fig.: TS 305



- > Factory standard extraction duct with two diameters for attaching an extraction unit
- > Outside nominal width $\pm \text{Ø } 30 / \text{Ø } 38 \text{ mm}$



- > Factory standard mitre stop pivots up to $\pm 60^\circ$
- > Grinding table pivots up to $\pm 45^\circ$



- > Hook and loop fastener pad for grinding disc available as optional accessory. Good grinding disc adhesion, easy replacement

Scope of supply

- > Adjustable angle stop
- > Grinding sheet

Model	TS 305
Article no.	3310305

Technical specifications	
Electrical connection	230 V/1 Ph ~50 Hz
Motor output	900 W
General instructions	
Grinding disc	$\text{Ø } 305 \text{ mm}$
Rotational speed	1 420 rpm
Table support	155 x 440 mm
Adjustment of angle stop	$\pm 60^\circ$
Pivoting grinding table	$\pm 45^\circ$
Dimensions	
Length x width x height	440 x 445 x 365 mm
Weight	30 kg

Accessories	Article no.
Hook and loop fastener pad	3357801

Grinding sheets	Article no.	PQ
> Hook and loop fastener		
Grain size 40	3357854	5 units
Grain size 40	3357856	5 units
Grain size 80	3357858	5 units
Grain size 100	3357860	5 units
Grain size 120	3357862	5 units
Grain size 150	3357865	5 units
Grain size 180	3357866	5 units
Grain size 240	3357867	5 units

Pack of 5
Grain size 40 to 240



PLATE ROLLING, FOLDING, PRESSING AND CUTTING

FP 30/BM 3

Folding machine FP 30 - universally deployable

Facts that impress in terms of quality, performance and price

- ▶ Folding machine FP 30 for bending and folding sheet metals
- ▶ Removable bending beam segments
- ▶ Convenient swivel movement of the bending beam via lever handle
- ▶ Premium quality bending beam
- ▶ For use on a vice

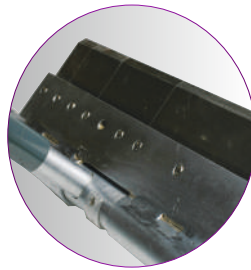
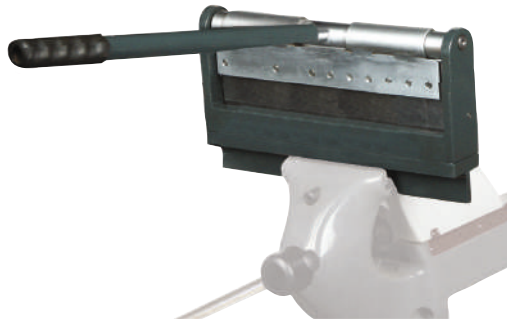

› Bending segment pieces 150 mm/75 mm/50 mm and 25 mm removable

Fig.: Folding machine FP 30

Model	FP 30	Max. folding performance at 90°	
Article no.	3244028	Aluminium/copper	300 x 2 mm
Performance features		Steel sheet	300 x 1 mm
Max material width	320 mm	Weight	10 kg
Max. sheet thickness	2.5 mm		

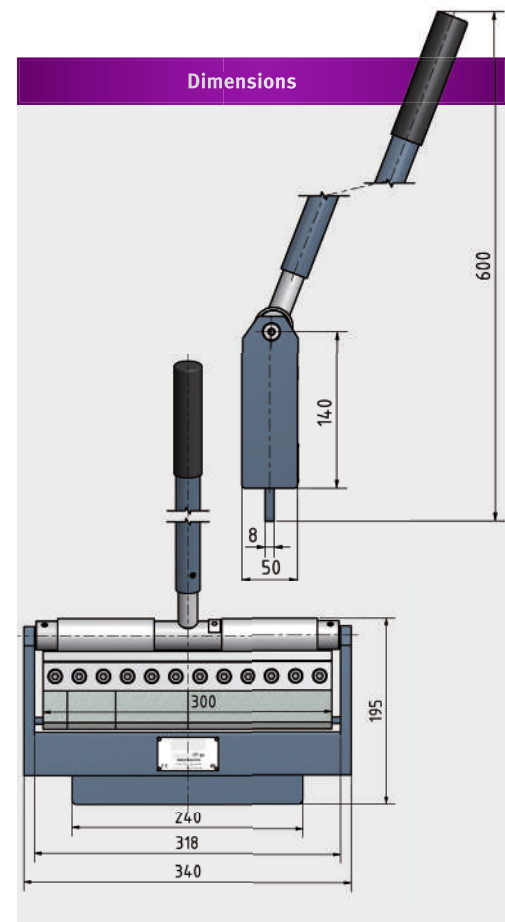

Three-roller roll bending machine BM3 - universally deployable

Facts that impress in terms of quality, performance and price

- ▶ Bending and rolling of wires, tubes and sheet
- ▶ Polished bending rollers
- ▶ Borne steel side frames (self-lubricating)
- ▶ Two removable unwinding rollers
- ▶ Material thickness and rolling radius separately adjustable
- ▶ For use on a vice
- ▶ Sturdy support surface

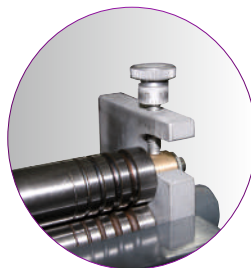
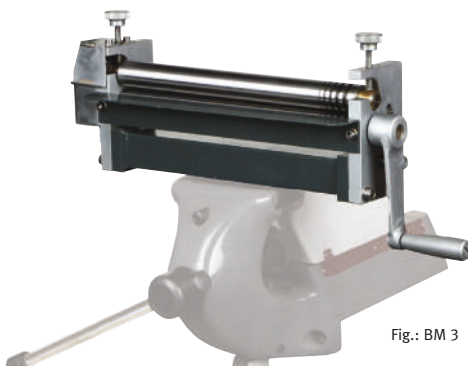

› Wire insert groove
Ø 1 - 2 - 3 - 4 - 5 mm

Fig.: BM 3

Model	BM 3	Rolling thickness max.	
Article no.	3244030	Steel sheet St. 37	1 mm
Performance features		stainless steel	1 mm
Max material width	310 mm	Aluminium/copper	2 mm
Bending Ø min.	35 mm	Brass	1 mm
Bending Ø max.	unlimited	Gold/silver/tinplate	2 mm
Weight	10 kg	Narrow widths	3 mm
		Round materials	1 - 5 mm
		Unwinding roller	Ø 30 mm

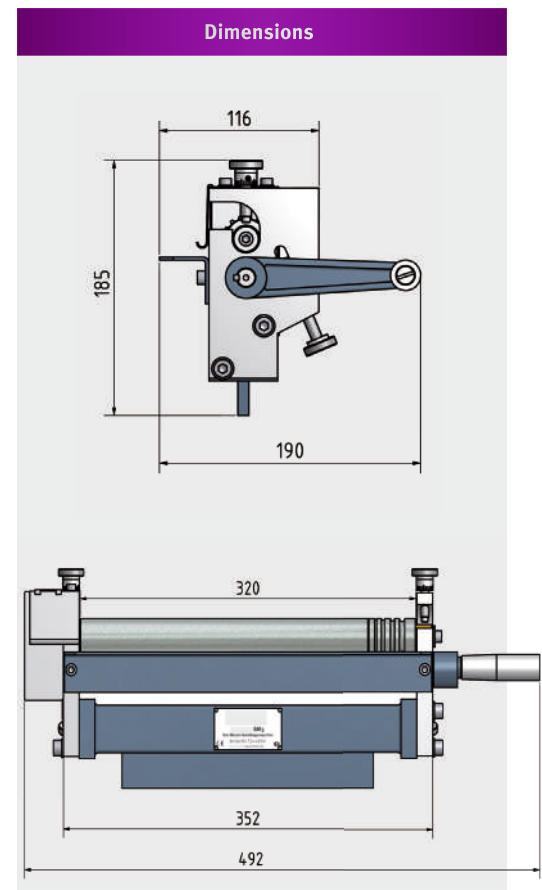

SAR 1000

Sheet metal working machine 3 in 1: plate rolling, folding and cutting. Ideally suited for demanding users

Facts that impress in terms of quality, performance and price

- ▶ Modern design and sturdy steel construction
- ▶ High level of design flexibility thanks to segmented folding rail with removable segments
- ▶ Operation via two large, adjustable and easily operable levers arranged at the side
- ▶ Scissor table with recessed measuring strips and right-angle stop on both sides
- ▶ Easily adjustable top, rear and bottom rollers
- ▶ Long support surface
- ▶ Adjustable rear stop and extensible front material support for safe support of large-format sheet metal



Fig.: SAR 1000

Scope of supply

- > Adjustable rear stop
- > Front material support
- > Tool



Optional accessory

- Chassis
> L x W x H: 1 185 x 500 x 700 mm
Art. no. 3242107

Model	SAR 1000
Article no.	3242100
Technical data	
Max material width	700 mm
Plate rolling	
Plate rolling (min.)	Ø 48 mm
Plate rolling (max.)	Ø unlimited
Steel sheet (S235JR)	up to 1 mm
stainless steel	up to 0.5 mm
Aluminium/copper	up to 1.5 mm
Brass	up to 1 mm
Gold/silver/tinplate	up to 1.5 mm
Unwinding roller Ø	48 mm
Folding	
Max. sheet thickness	2.5 mm*
Aluminium/copper	up to 1.5 mm
Steel sheet (S235JR)	up to 1 mm
Number of segments	7
Cutting	
Cutting capacity max.	up to 1 mm
Weight	290 kg

Plate rolling

- > Adjusting screws for material thickness with scale
- > Ground bending rollers with wire insert grooves on the bottom and front rollers

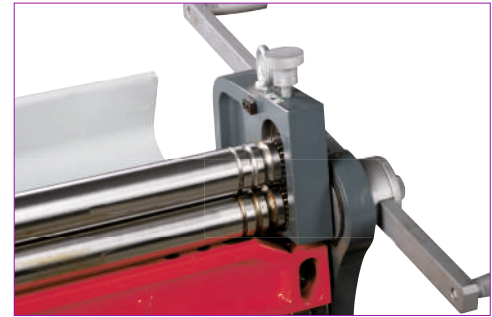

Folding

- > Premium folding bars
- > Spring hold-down unit
- > Segmented folding rail 40 mm/50 mm/65mm /100 mm/180 mm/255 mm/380 mm for cassette bending



Cutting

- > Clean and burr-free cutting thanks to top and bottom blades made of quality grade steel

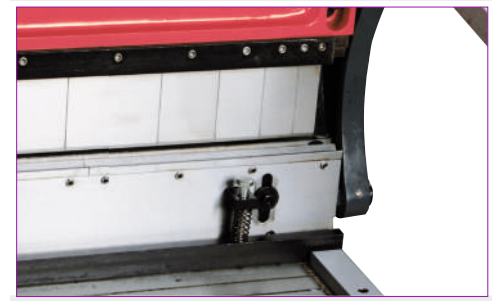

Dimensions

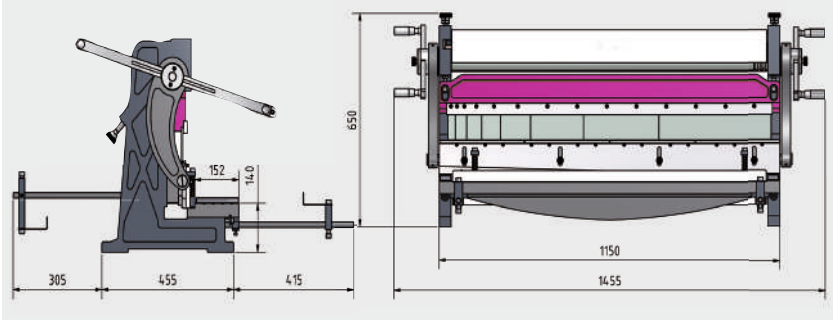

PS 125/PS 150/PS 300

Lever-action snips - a quality product for trade applications

Facts that impress in terms of quality, performance and price

- ▶ For cutting metal plates, sheet, round and flat steel
- ▶ Sturdy snip body
- ▶ Good ergonomic cutting geometry
- ▶ Easy, strength-saving cutting over the entire length of the cut
- ▶ Robust handle ensures a good grip
- ▶ Premium blades
- ▶ The workpiece to be cut is held down in horizontal position by the hold-down unit
- ▶ Stable base and holes drilled for stationary fastening



Fig.: Ps 125

Fig.: Ps 300

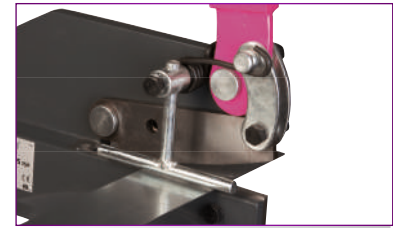

- > Premium blade with long service life
- > Hold-down unit prevents sheet twisting during cutting
- > Strong springs prevent the shears closing autonomously

Replacement blade set	Article no.
> 2-part	
for PS 125	3241025
for PS 150	3241026
for PS 300	3241028

Model	PS 125	PS 150	PS 300
Article no.	3241006	3241007	3241012

Cutting capacity			
Max. cutting length (b)	95 mm	115 mm	235 mm
Max. sheet thickness (c)	3 mm*	4 mm*	4 mm*
Dimensions L x W x H	245 x 110 x 935 mm	325 x 120 x 960 mm	490 x 155 x 1 340 mm
Weight	8.7 kg	10.7 kg	23 kg

*Not over the entire length - material steel (S235JR), stainless steel up to 1 mm



DDP 10/DDP 20/DDP 30/DDP 50

Precision arbour presses with rugged and solid design.

For mechanical workshops and repair operations

Facts that impress in terms of quality, performance and price

- ▶ For pressing in and out of bearings, mandrels, bushings, spindles, pins
- ▶ Stable design
- ▶ Premium grey cast body
- ▶ Variably adjustable lever
- ▶ Baseplate adjustable in four positions
- ▶ For fastening on a workbench

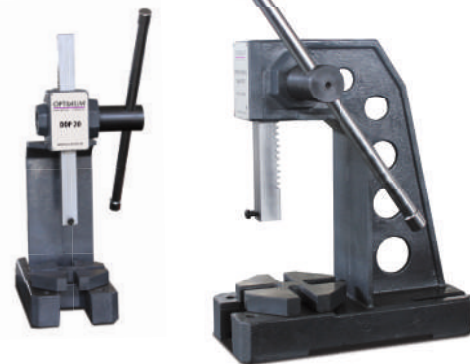

Model	DDP 10	DDP 20	DDP 30	DDP 50
Article no.	3359011	3359012	3359013	3359015
Technical specifications				
Max. workpiece height	123 mm	195 mm	310 mm	459 mm
Throat	95 mm	120 mm	150 mm	226 mm
Dimensions				
L x W x H max.	270 x 180 x 410 mm	430 x 235 x 680 mm	455 x 260 x 850 mm	650 x 350 x 785 mm
Stamp size (L x W x H)	25 x 25 x 240 mm	32 x 32 x 345 mm	38 x 38 x 455 mm	50 x 50 x 647 mm
Weight	14 kg	33 kg	55 kg	167 kg

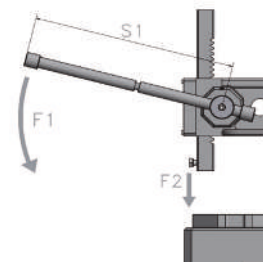

Effective force		DDP 10		DDP 20		DDP 30		DDP 50	
Hand force	F1	392.4 N	589 N	392.4 N	589 N	392.4 N	589 N	392.4 N	589 N
		(40 kg)	(60 kg)	(40 kg)	(60 kg)	(40 kg)	(60 kg)	(40 kg)	(60 kg)
Long lever	S1	340 mm		450 mm		600 mm		850 mm	
Effective force	F2	7 480 N	11 220 N	8 364 N	12 555 N	7 705 N	11 566 N	10 251 N	15 372 N
		(763 kg)	(1 143 kg)	(853 kg)	(1 280 kg)	(786 kg)	(1 179 kg)	(1 045 kg)	(1 567 kg)

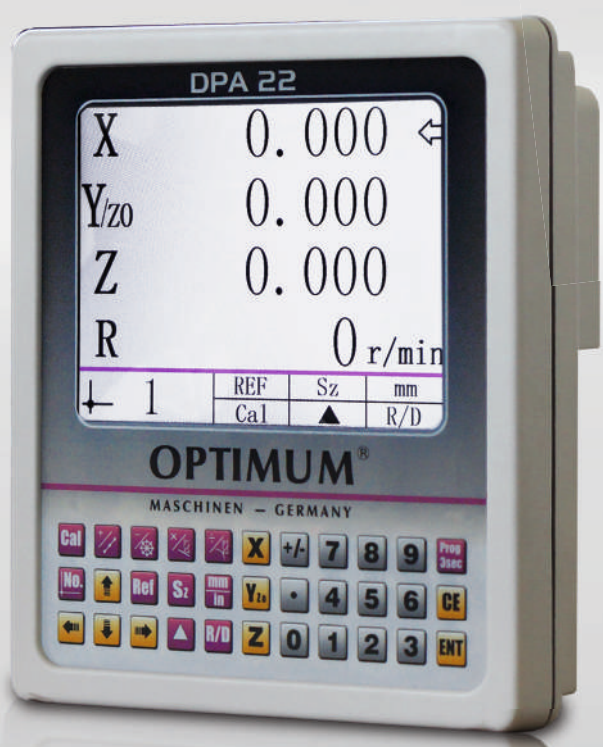

MACHINES - COOLANT ACCESSORIES, MEASURING EQUIPMENT, LAMPS

Robust machine lamps for individual use:

NEW

LED machine and workshop lighting

- › Electrical connection 230 V ~ 50Hz or DC 24V
- › LED service life > 60 000 h
- › Colour temperature neutral white 5 000 K
- › Vibration-proof at 10 to 55 Hz (amplitude 0.35 mm), shockproof up to 50 g
- › Safety glass
- › Degree of protection IP65, protection class I (operation with PE connection)
- › Robust, high-luminosity machine lamp
- › Operating mode: Continuous operation
- › Aluminium housing with black side parts
- › Maximum permissible ambient temperature Tmax. 50 °C
- › Reflection angle 120° (reflector)
- › Bracket-mounted, swivel angle ± 45°

Model	MWL 1	MWL 2	MWL 3	MWL 4
Article no. AC230V	3351030	3351031	3351032	3351033
Article no. DC24V	3351040*	3351041*	3351042*	3351043*
Services	28 Watts	56 Watts	84 Watts	112 Watts
Lamp length	340 mm	630 mm	920 mm	1 210 mm
Luminosity (Lumen)	3 456 Lm	6 800 Lm	10 300 Lm	13 600 Lm

*Required safety transformer as per EN 61558-2-6 not included in scope of delivery

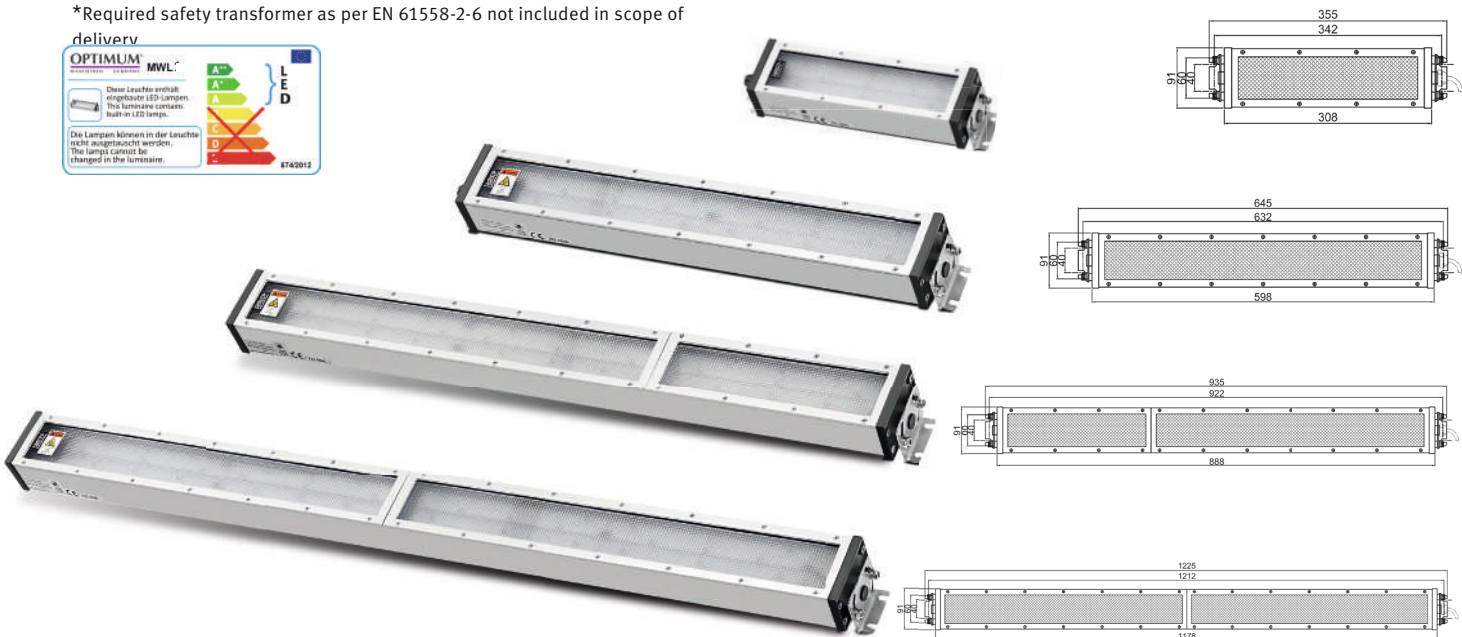

NEW

Model	LED workbench lamp WBL 3
Article no.	3351062

- › Electrical connection 3 x 1 Watt LED / 230 V ~50 Hz
- › Luminosity 390 Lm
- › Colour temperature: 5 600 - 6 000 K
- › Articulated arm with sleeve for best possible mobility
- › Excellent positional stability
- › Swivel head
- › Impact-proof, easy-to-clean plastic housing
- › Arm length 520 mm
- › Degree of protection IP20
- › Magnetic base, fixing bracket
- › Integrated transformer

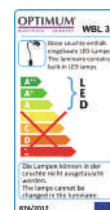

NEW

LED machine and workshop lamp

- › Electrical connection 6 x 2 Watt LED / 230 V ~50 Hz
- › Luminosity 1 020 Lm
- › Colour temperature: 5 600 - 6 000 K
- › Robust and powerful articulated machine lamp
- › State of the art LED technology
- › Low exterior temperature; lubricants and coolants do not burn on
- › Reflection angle 60° (reflector)
- › Base bracket-mounted, rotates through 310°
- › Maximum permissible ambient temperature Tmax. 50 °C
- › LED service life > 60 000 h
- › Degree of protection IP65, protection class I (operation with PE connection)
- › Aluminium housing
- › Swivel head

Model	MWG 6-100	MWG 6-600	MWG 6-720
Article no.	3351051	3351052	3351053

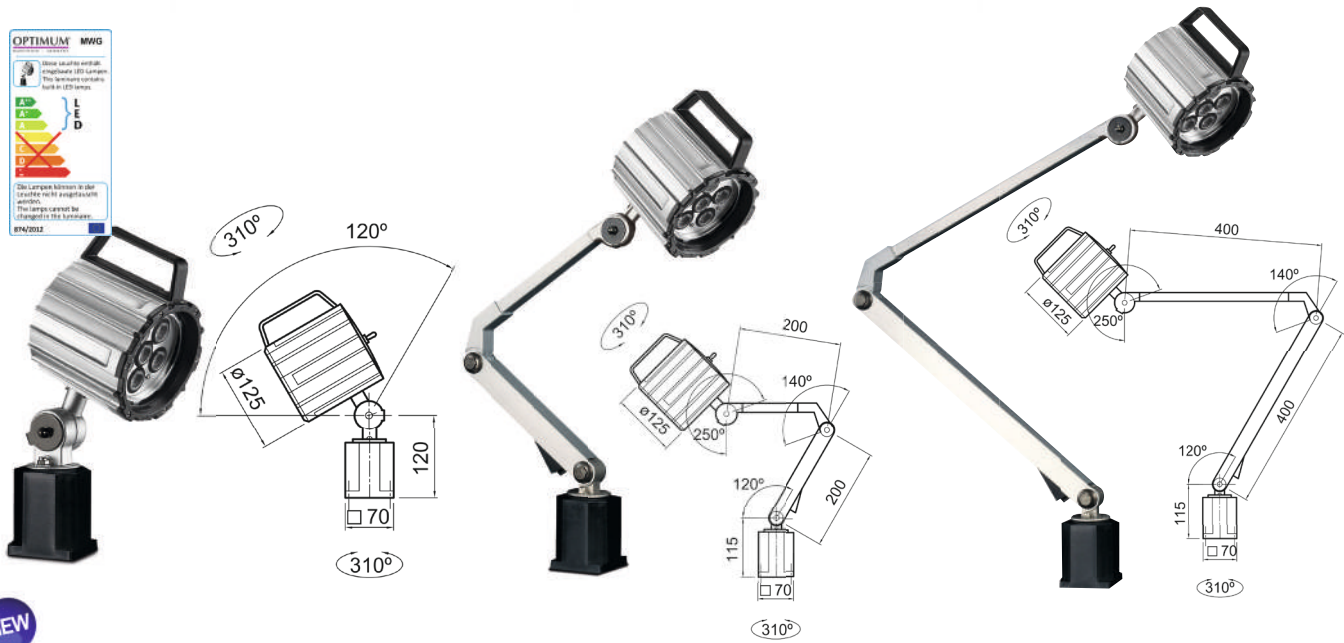
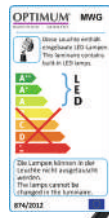

NEW

Model	LED magnifying lamp MBLV
Article no.	3351090
<ul style="list-style-type: none"> › Electrical connection 14 W / 230 V ~50 Hz › Large magnifying glass: 125 mm diameter › Luminosity dimmable 10 - 100 % › Joint easily adjustable and lockable thanks to clamp screw › Pleasant, glare-free light › Articulated arm length 830 mm › IP Degree of protection: IP20 › Magnifying lamp with 1.5x optical magnification 	

Model	Machine lamp LED 3-500
Article no.	3351010
<ul style="list-style-type: none"> › Electrical connection 3 x 1 W LED / 230 V ~50 Hz › Colour temperature: 4 000 - 4 500 K › Made of oil-resistant and impact proof plastic › No impairment of the service life through vibration or knocks › Optimum mobility of the articulated arm › IP degree of protection IP64 (dust and splash-water protected) › Lifetime 60 000 operating hours › Low exterior temperature; lubricants and coolants do not burn on › Mains supply cable approx. 1.2 m › Energy-saving and durable machine lamp 	

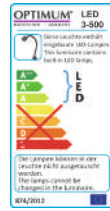
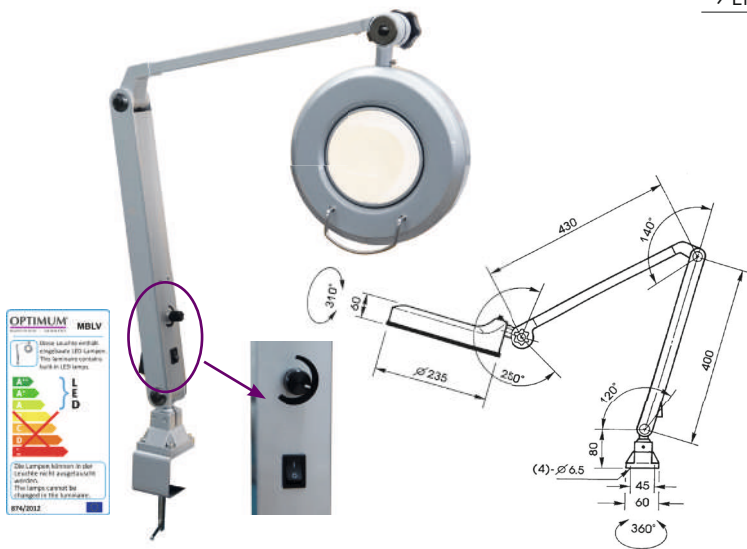

Preface

Drilling

Milling

Turning

Saws









Grinding

Polishing

Lamps

Measuring

Coolant accessories

	Designation	Size	Article no.	
	Coolant hose set 2 pcs. articulated hose; 300 mm 2 pcs. round nozzles, 1 pc. shut-off valve 1 pc. magnetic base	1/4"	3356700	
		1/2"	3356801	
	Coolant hoses 4 pcs. articulated hose; 150 mm	1/4"	3356701	
	Coolant hose set 2 pcs. articulated hose; 150 mm 2 pcs. NPT coupling 1/4" and 1/8" 3 pcs. round nozzle 1/16" / 1/8" / 1/4" 1 pc. flat nozzle	1/4"	3356702	
		1/2"	3356802	
	Coolant hose set 2 pcs. articulated hose; 150 mm 2 pcs. NPT coupling 1/4" and 1/8" 2 pcs. round nozzle 1/8" / 1/4", 2 pcs. shut-off valve	1/4"	3356703	
	Grips	1/4"	3356710	
		1/2"	3356810	
	Articulated hose Hose roll 15 metres	1/4"	3356711	
		1/2"	3356811	
	Circular nozzles	1/4"	3356712	
		1/2"	3356812	
	Flat nozzles 5-hole 5 units	1/4"	3356713	
		1/2"	3356820	
	Flat nozzles 5 units	1/4"	3356714	
		1/2"	3356813	
	Flat nozzle 75 mm wide 2 units	1/4"	3356715	
		1/2"	3356814	
	Connector Threaded connection RP3/8" 5 units	1/4"	3356716	
		1/2"	3356815	
	Connector Threaded connection RP1/2" 5 units	1/2"	3356816	
	Y connector 5 pcs. 1/4" 2 pcs. 1/2"	1/4"	3356717	
		1/2"	3356817	
	Cap 5 units	1/4"	3356718	
		1/2"	3356818	
	Shut off valve for articulated hose 2 pcs.	Threaded connection RP1/4"	1/4"	3356719
		Threaded connection RP1/2"	1/2"	3356819



	Designation	Size	Article no.
	Coolant hoses basic equipment 1/4" - No. 1 <ul style="list-style-type: none"> › 8 pcs. articulated hose 150 mm › 2 pcs. each round nozzle 1/16" / 1/8" / 1/4", › 2 pcs. NPT coupling 1/4" and 1/8", › 1 pc. flat nozzle, › 1 pc. Y-distributor, › 2 pcs. shut-off valve inside and outside, › 2 pcs. shut-off valve inside - 1/4", › 2 pc. NPT extension, › 1 pc. magnetic base, 1 pc. flexible sealing tape 	1/4"	3356704
	Coolant hoses basic equipment 1/4" - No. 2 <ul style="list-style-type: none"> › 6 pcs. articulated hose 150 mm › 2 pcs. each round nozzle 1/16" / 1/8" / 1/4", › 2 pcs. each NPT coupling 1/4" and 1/8", › 5 pcs. flat nozzle, › 4 pcs. 90° nozzle, › 1 pc. Y-distributor, › 1 pc. shut-off valve, inside and outside, › 1 pc. shut-off valve, inside - 1/4" › 1 pc. grips 	1/4"	3356705
	Coolant hoses basic equipment 1/2" - No. 1 <ul style="list-style-type: none"> › 6 pcs. articulated hose 150 mm › 2 pcs. each round nozzle 1/2" / 3/8" / 1/4", › 2 pcs. each NPT coupling 1/4" and 1/2", › 1 pc. flat nozzle, › 3 pcs. 90° round nozzle 1/2" / 3/8" / 1/4", › 1 pc. Y-distributor, › 1 pc. shut-off valve, inside and outside, › 1 pc. shut-off valve, inside - 1/2" › 1 pc. grips 	1/2"	3356800

Universal coolant unit 230 V/1 Ph	3352002
› Max. delivery height 2.5 m / delivery rate 8 l/min	
› Tank content 11 l / dimensions L x W x H: 370 x 245 x 170 mm	
› Complete with tank, flexible tube, hose and switch/plug combination	
› Magnetic base fastener for coolant hose	

Coolant mist lubricator MMC1	3356663
› Magnetic base with a holding force of 75 kg	
› Base size L x W x H: 62 x 50 x 55 mm	
› Screw connection for external compressed air supply	
› Flexible and stable hose with a length of 500 mm	

NEW

AQUACUT C1	3530030
• 10 litre canister	
• For mixing emulsions	
• Drilling and cooling emulsion	
• High-pressure resistant and containing mineral oil, for long tool life and clean surfaces	
• Emulsifiable with water, microbe-resistant and kind to the skin	

Coolant hose KMS 2	3356660
› Two flexible and stable coolant hoses made of individual plastic elements	
› Not electrically conductive	
› Magnetic base holding force up to 50 kg	
› Length of coolant hoses each 335 mm	
› Insensitive to most solvents and chemicals	
› Universally deployable on all tool machines	

Preface

Drilling

Milling

Turning

Saws

Grinding

Polishing

Lamps

Coolant accessories

Index



NEWALL - DP700

Digital position display DP700 for precise measurement of travel and positioning on the machine and drives



Digital position display DP700 3390073

Extension kit - Spherosyn milling 3390220

- › Digital position display DP700
- › Display holder
- › Attachment parts for assembling three axes Spherosyn

Extension kit - Microsyn milling 3390230

- › Digital position display DP700
- › Display holder
- › Attachment parts for assembling three axes Microsyn

Extension kit - turning 1 3390405

- › Digital position display DP700
- › Display holder
- › Attachment parts for assembling one axis Spherosyn and one axis Microsyn greater than 300 mm

Extension kit - turning 2 3390406

- › Digital position display DP700
- › Display holder
- › Attachment parts for assembling one axis Spherosyn and one axis Microsyn less than 300 mm

Complete attachment kit MH 35G 3390330

- › Digital position display DP700
- › 3 pcs. measuring strip Microsyn
- › Display holder · Attachment parts measuring strip assembly

Complete attachment kit MH 50G 3390346

- › Digital position display DP700
- › 3 pcs. measuring strip Microsyn
- › Display holder · Attachment parts measuring strip assembly

Complete attachment kit TH 3309 3390420

- › Digital position display DP700
- › 2 pcs. measuring strip Microsyn · 1 pc. measuring strip Spherosyn
- › Display holder · Attachment parts measuring strip assembly

Complete attachment kit TH 3610 / TH 4010 3390430

- › Digital position display DP700
- › 2 pcs. measuring strip Microsyn · 1 pc. measuring strip Spherosyn
- › Display holder · Attachment parts measuring strip assembly

Digital position display DP700

- › Powerful DP display with many functions
- › Ergonomically shaped, slim-line aluminium housing
- › Has all necessary functions for a variety of machining applications
- › The operator works with an intuitive and user-friendly interface
- › Developed and manufactured in England
- › IP67 encoding units can be deployed under the toughest ambient conditions with a high degree of precision.
- › Five-year warranty on indicator and read heads
- › The linear encoding units are insensitive to soiling in the workshop, such as coolant, water, dust, chips, knocks and vibrations
- › No maintenance required
- › Fast and easy installation

Possible functions

Number of axes	2 or 3 axes	
	Milling machine	Lathe
Undo	•	•
Digfind (position search function)	•	•
Centrefind	•	•
Radius/diameter	•	•
Absolute/steps	•	•
mm/inch	•	•
Axes preset/zero set	•	•
Approach zero point	•	•
Tool repository		•
Taper		•
Axis addition		•
PCD/bolt circle	•	
Arc control	•	
Polar coordinates	•	
Slotted rail	•	
Input mode/Sub-datum	•	•
Feed function	•	•
RS232 output	•	•
Linear error compensation	•	•
Segmental error compensation	•	•
Protection classes	IP 40 (digital display) IP 54 (front control panel)	
Languages	DE, EN, FR, ES, IT TU, TR, CZ, RU, PT, DK	

Measuring strips

Analogue measuring systems (Spherosyn & Microsyn)

The Spherosyn and Microsyn length measuring systems are specially designed for requirements in the demanding environment of a workshop. The measuring transducers use a totally unique design with all components sealed and protected. This means that you can achieve precise and reliable measured values, even if the measuring systems are immersed in coolant, oil water or lubricant.



The advantages

- › Easy to install – low assembly costs
- › Degree of protection IP67
- › Impermeable to coolants, oil, dust, chips and almost all workshop influences
- › No risk of broken or scratched glass
- › Tolerant towards vibration and magnetic interference
- › No regular maintenance or cleaning needed
- › No mechanical wear
- › Lifetime guarantee on the measuring probe

Worldwide, more than 400 000 Spherosyn and Microsyn transducers offer the highest degree of reliability.

Spherosyn and Microsyn can be used both for the digital position display DP700 and also be integrated for a variety of feedback applications, such as CNC systems and PLC.

How does that work?

The Spherosyn and Microsyn measuring probes rely on the principle of electro-magnetism and consist of a stainless steel or carbon fibre tube filled with individual, classified, highly precise steel balls. The balls are pre-stressed and calibrated in a temperature-controlled environment in the tube.

The read head consists of six coils which are wound around a composite fibre coil. The coils and the required electronic circuitry are sealed on the inside of the read head by a special potting method. Applying voltage to the coil generates an electro-magnetic field in the read head. Due to the curvature of the balls on the inside of the tube, the output signal varies depending on the position of the coils above the balls. When the measuring head runs over the probe, signals are generated by the relative axial movement induced at each probe coil.



Difference between Spherosyn and Microsyn measuring probes

Analogue measuring systems	Spherosyn	Microsyn
Measuring length	51 mm to 2 945 mm	30 mm to 1 000 mm
Scale	15.25 mm	6.5 mm
Measuring probe material	stainless steel	Carbon fibre
Measuring probe length, total	Measuring length + 250 mm	Measuring length + 175 mm
Read head dimensions	51 mm x 131 mm x 28 mm	35 mm x 75 mm x 20 mm
Maximum feed	2.0 metres per second	0.75 metres per second
Output cable length	3.5 metre stainless steel armouring (Extension cable available as accessory page 208)	
Precision	+/- 10 micron	
Repetition accuracy	Within one resolution sample	
Drive input	85mA +/-5mA	
Output	2.0 V +/-0.5 RMS, 1 kHz phase-analogue, 360 degrees per 12.7 mm	
Suitable	For large machines and machines without space problems when fitting the probes	For small machines with space problems when fitting the probes

Analogue measuring systems (Spherosyn & Microsyn)



Fig.: Spherosyn with optional fastening



Fig.: Microsyn with optional fastening

Measuring strips Spherosyn	Article no.
MS S2G - 51 mm	3391005
MS S2G - 102 mm	3391010
MS S2G - 152 mm	3391015
MS S2G - 178 mm	3391018
MS S2G - 203 mm	3391020
MS S2G - 229 mm	3391023
MS S2G - 254 mm	3391025
MS S2G - 305 mm	3391030
MS S2G - 356 mm	3391035
MS S2G - 406 mm	3391040
MS S2G - 457 mm	3391046
MS S2G - 508 mm	3391051
MS S2G - 559 mm	3391056
MS S2G - 610 mm	3391061
MS S2G - 660 mm	3391066
MS S2G - 711 mm	3391071
MS S2G - 762 mm	3391076
MS S2G - 813 mm	3391081
MS S2G - 864 mm	3391086
MS S2G - 914 mm	3391091
MS S2G - 965 mm	3391097
MS S2G - 1 016 mm	3391101
MS S2G - 1 118 mm	3391111
MS S2G - 1 168 mm	3391117
MS S2G - 1 219 mm	3391121
MS S2G - 1 270 mm	3391127
MS S2G - 1 321 mm	3391132
MS S2G - 1 372 mm	3391137
MS S2G - 1 422 mm	3391142
MS S2G - 1 473 mm	3391147
MS S2G - 1 524 mm	3391152
MS S2G - 1 626 mm	3391162
MS S2G - 1 727 mm	3391172
MS S2G - 1 829 mm	3391182
MS S2G - 1 930 mm	3391193
MS S2G - 2 032 mm	3391203
MS S2G - 2 134 mm	3391213
MS S2G - 2 235 mm	3391223
MS S2G - 2 337 mm	3391233
MS S2G - 2 438 mm	3391243
MS S2G - 2 540 mm	3391254
MS S2G - 2 642 mm	3391264
MS S2G - 2 743 mm	3391274
MS S2G - 2 845 mm	3391284
MS S2G - 2 946 mm	3391294

Measuring strips Microsyn	Article no.
MS M2G - 30 mm	3392003
MS M2G - 50 mm	3392005
MS M2G - 75 mm	3392007
MS M2G - 100 mm	3392010
MS M2G - 125 mm	3392012
MS M2G - 150 mm	3392015
MS M2G - 175 mm	3392017
MS M2G - 180 mm	3392018
MS M2G - 200 mm	3392020
MS M2G - 225 mm	3392022
MS M2G - 250 mm	3392025
MS M2G - 275 mm	3392027
MS M2G - 300 mm	3392030
MS M2G - 325 mm	3392032
MS M2G - 350 mm	3392035
MS M2G - 400 mm	3392040
MS M2G - 450 mm	3392045
MS M2G - 500 mm	3392050
MS M2G - 550 mm	3392055
MS M2G - 600 mm	3392060
MS M2G - 650 mm	3392065
MS M2G - 700 mm	3392070
MS M2G - 750 mm	3392075
MS M2G - 800 mm	3392080
MS M2G - 850 mm	3392085
MS M2G - 900 mm	3392090
MS M2G - 950 mm	3392095
MS M2G - 1 000 mm	3392100

Accessories	Article no.
Extension cable 1 metres	3393601
Extension cable 2 metres	3393602
Extension cable 3.5 metres	3393603
Extension cable 5 metres	3393604
Extension cable 10 metres	3393605

DPA 21 / DPA 22

Digital positioning displays for versatile deployment for three axes with speed display. Premium technology and durable industrial quality

Differences:

DPA 21

- ▶ LED display

DPA 22

- ▶ LCD display
- ▶ High-contrast display
- ▶ Simplified menu navigation
- ▶ Graphical input for cycle programming



DPA 22



DPA 21

Digital position display	Article no.
DPA 21 (LED display)	3384020
DPA 22 (LCD display)	3384022
<ul style="list-style-type: none"> › User-friendly membrane keyboard, splash water protected, sealed and dazzle free › Switchable for milling machine and lathe, freely selectable input signal (sinus/square), e.g. usable for glass measuring probes and/or magnetic strip system › Greater operation accuracy › Clear reduction of manufacturing times › Reduction of error quota › X, Y/Z0, Z axis each with 8-digit display › Sensor supplied for acquiring spindle speeds › Three measuring inputs can be evaluated with seven correction memory stores each for tools › Dimensions L x W x H: 230 x 80 x 260 mm . Weight: 2 kg 	

Possible functions

- › Calculator, speed display, axis coupling (total Z), sub-D connector sockets, absolute/incremental operation, conversion inch/metric thread, bolt circle computation (chain dimension), coordinates in circle (pitch circle), drill holes in circle (pitch circle), measured values switchable radius/diameter, Zero reset data default, self diagnostics, reference point, linear error correction, 99 tool memory slots

Scope of delivery

- › Speed sensor
- › Holder
- › Power supply 24 V



Magnetic strip

- › Magnetic strip for assembly machines that do not have enough space for magnetic measuring probes
- › Connector 9-pin

Length 1 100 mm	3383978
Length 2 000 mm	3383979
Read head active	3383934

- › for magnetic strip

Measuring strips	Article no.
------------------	-------------

- › Fully encapsulated measuring systems with high precision glass measuring probe
- › Resolution 5 µm
- › Accuracy ± 0.003 mm
- › Sampling slide borne on miniature ball bearings and connected to the assembly base by a coupling
- › Protected against dust, chips and splash water by a rubber lip
- › Flexible metal protection hose
- › Connecting cable three metres; four metres as of ML 620
- › Without assembly

ML 80 mm	3384108
ML 100 mm	3384110
ML 120 mm	3384112
ML 170 mm	3384117
ML 220 mm	3384122
ML 270 mm	3384127
ML 320 mm	3384132
ML 370 mm	3384137
ML 420 mm	3384142
ML 470 mm	3384147
ML 520 mm	3384152
ML 570 mm	3384157
ML 620 mm	3384162
ML 670 mm	3384167
ML 720 mm	3384172
ML 770 mm	3384177
ML 820 mm	3384182
ML 870 mm	3384187
ML 920 mm	3384192
ML 970 mm	3384197
ML 1 020 mm	3384202
ML 1 250 mm	3384225
ML 1 400 mm	3384240
ML 1 520 mm	3384252
ML 1 670 mm	3384267
ML 1 940 mm	3384294
ML 2 010 mm	3384295
ML 3 000 mm	3384300
Factory assembly ML	9000410

- ▶ Per measuring strip

Preface

Drilling

Milling

Turning

Saws

Grinding

Polishing

Lamps

Measuring

Index

Digital 3-axis position display for milling machines and lathes with speed display

Digital 3-axis position display DRO5	
Article no.	3383975
<ul style="list-style-type: none"> › Digital 3-axis position display for milling machines (X - Y - Z) and for lathes (X, Z, Z₀) › For measuring positions › Rev counter › Three incremental inputs › Four-line LCD display › User-friendly menu navigation › Rugged aluminium housing › Programming from the front › Dimensions length 98 mm x width 65 mm x height 134 mm 	
Including	
<ul style="list-style-type: none"> › Speed sensor cable length 5 metres › 3 pcs. magnetic sensors without magnetic strip › Power supply cable length 6 metres › Magnetic plate 	



Accessories	Article no.
Magnetic strip length 1 100 mm	3383978
Magnetic strip length 2 000 mm	3383979
Magnetic strip per metre	3383980
Factory assembly	
Magnetic strip three axes	9000420
Speed sensor	9000421

Measuring accessories

Dial gauge	3385090
<ul style="list-style-type: none"> › Precision as per DIN 878 › Metal housing matt chrome plated › Clamping shank 8 mm › Scale 0.01 mm › Measuring range 10 mm › Outer ring with two adjustable tolerances › Scale rotatable via outer ring for easy 	



Precision magnetic measuring stand	3356650
<ul style="list-style-type: none"> › Measuring column Ø 12 mm x 181 mm › Traverse Ø 10 mm x 160 mm › Magnetic base L x W x H: 50 x 62 x 55 mm › Holding force 50 kg › Dial gauge holder with mounting hole for dial gauges, fine indicators, electrical length measuring probes 	



Fig.: Dial gauge and measuring stand

Machine spirit level	3385064
<ul style="list-style-type: none"> › With prismatic base for levelling horizontal surfaces and shafts › Compact and stress-free installation of the longitudinal spirit level guarantees constant precision › Precision 0.02 mm/m › Horizontal and longitudinal spirit level as per DIN 2276 Form B › Eliminates time-consuming adjustment work › Heat protected handle › Dimensions: 200 mm x 46 mm x 46 mm 	



Measuring and test platen	3385060
<ul style="list-style-type: none"> › Dimensions L x B x W: 630 x 400 x 100 mm › Precision 7 µ › Granite › Thermally and dynamically stable › Compressive strength 250 - 260 N/mm² › DIN 876/0 › Corrosion-free 	



Please note

- › These offers are intended exclusively for business owners, retailers and tradespersons who are making a purchase in pursuit of their profession or self-employment. This is an explicit CONDITION FOR THE CONCLUSION OF A CONTRACT. Consumers are not eligible to purchase as per Section 13 BGB (German Civil Code)
- › We accept no liability for printing errors, mistakes or incorrect representation.
- › Subject to technical modifications and visual changes.
- › Illustrations show optimal accessories in some cases
- › Delivery is effected solely on the basis of our terms of delivery and payment.
- › The machines are delivered partly knocked down for transportation reasons.
- › All items are sold through specialist retailers.
- › The goods shall remain our property until payment has been received in full.
- › Our retention of title shall remain valid in case of sale to a third-party.
- › Legal warranty conditions apply for businesses.
- › Copying and reproduction in full or in part is subject to written approval by us.
- › Please note that transport packaging surcharges apply for some machines in this catalogue to cover transport units, packaging and packaging overheads.

Warranty conditions

- › Independently of your legal warranty entitlement, OPTIMUM provides a guarantee on the basis of the following provisions for the period as stated in the catalogue for the respective machine; the guarantee period starts on the date of sale of the machine to the end customer. OPTIMUM offers a guarantee on catalogue products where a guarantee is specifically indicated. The guarantee exclusively covers defects resulting from material or manufacturing errors. The warranty exclusively covers spare parts but not the transport and installation costs or labour and ancillary services necessary for eliminating defects. The guarantee excludes unintended use or improper application such as overloading of the machine or the use of non-approved and unsuitable tools, use of force, damage caused by external influences or by foreign bodies, e.g., dust, chips or stones, damage caused by failure to observe the Operating Instructions, e.g., connection to the wrong mains voltage or current, failure to observe assembly instructions, conversions and extensions carried out by the customer, as well as normal wear. The guarantee also excludes partially or fully disassembled machines and machine tools. When claiming against guarantee/warranty, you must submit the original sales receipt showing the date of purchase. Repairs under guarantee/warranty may be performed by authorised partners only who will be named by the guarantee/warranty provider. The guarantee/warranty is restricted to the end customer of the new machine and is not transferrable.

General notes on operating our machines

- › Our machines must be supervised at all times during operation. Leaving the machine during operations constitutes gross negligence.
- › The details on machine precision are found in the technical data of the catalogue pages. If you do not find any values here, please contact info@optimum-maschinen.de for more detailed information.
- › The stated precisions are achieved under standardised conditions (correct installation of the machine and ambient temperature of 20 °C). The machines are not designed for continuous operation.
- › Please note that operators are required to make conversions in the event of installing third-party chucks or flanged chucks to reach the stated, technically possible rotating diameter.

Operation of machines with frequency converters

› Electrical connection only by a qualified electrician

Machines with frequency inverters or inverters must not be operated via an ordinary plug. A permanent connection is required. The drive components conduct a high leakage current via the protective conductor. Touching conductive parts when the protective conductor is interrupted can result in death or serious injury.

› Building electrics:

In order to avoid tripping of residual current circuit breakers - if present in the building electrics - an all-current-sensitive residual current circuit breaker type B is required.

AC - sensitive AC type RCDs (AC only) are not suitable for frequency inverters. AC sensitive earth-leakage circuit breakers of type AC are no longer in use and are no longer permitted in Germany.

COMPRESSORS / COMPRESSED AIR TECHNOLOGY

Entry-level models



The assembly professionals



The solid compressors for craftsmen



Mobile professional compressors for craftsmen with maximum equipment



Stationary - high performance in confined spaces



Silent compressors - for usage right next to your working space



Screw-type compressors and fixed screw compressors



Compressed air distribution, pipe connection systems



Compressed air application - compressed air tools for different applications



CLEANING TECHNOLOGY

High pressure cleaner
Hot and cold water



Fresh and waste water pumps,
submersible pumps, garden pumps
and domestic waterworks



Single disc machines
Scrubbing machines
Double roller machine



Ride-on scrubbing machines



Sweepers
Ride-on sweeper



Wet/dry vacuum cleaners



Dry vacuum cleaners



Special vacuum cleaners



Accessories
Nozzles, brushes, hoses,
filter bags, cartridge filter





WELT DER MASCHINEN

YOU WILL FIND MORE PRODUCTS IN OUR MAIN CATALOGUES



optimum-machines.com



holzstar-machines.com
holzstar.com



metalkraft-machines.com



cleancraft.eu



schweisskraft.com



en.unicraft.de



aircraft-compressors.com

DISCOVER OUR PRODUCT VIDEOS NOW!





Are you familiar with our YouTube channel, Optimum Machines?

You can view all of our product videos here. We always seek to offer you a wide range and high quality selection of videos.

Subscribe to our YouTube channel, to avoid missing any of the new videos:
www.youtube.com/user/OptimumMaschinen

Your specialist retailer:



Sales Germany:

OPTIMUM Maschinen Germany GmbH
Dr. Robert-Pfleger-Str. 26
96103 Hallstadt/Germany

Phone: +49 (0) 9 51 - 96 555 - 0
Fax: +49 (0) 9 51 - 96 555-888

e-Mail: info@optimum-maschinen.de



www.optimum-machines.com

Sales Austria:

AIRCRAFT Kompressorenbau und
Maschinengroßhandel GmbH
Gewerbestraße Ost 6
4921 Hohenzell / Austria

Phone: +43 (0) 77 52 - 70 929 - 0
Fax: +43 (0) 77 52 - 70 929 - 99

e-Mail: info@aircraft.at
Web: www.aircraft-compressors.com



OPTIMUM Cap
Part no. 9000072